

EFB24-S N4 - Damper Actuator

NEMA 4, On/Off, Spring Return, 24 V



Technical Data	
Power Supply	24 VAC±20%, 50/60Hz, 24 VDC+20%/-10%
Power Consumption Running	9.5 W
Power Consumption Holding	4.5 W
Transformer Sizing	16 VA (class 2 power source)
Shaft Diameter	1/2" to 1.05" round, centers on 3/4" with insert, 1.05" without insert
Electrical Connection	terminal block(s) inside junction box with knockouts
Overload Protection	electronic throughout 0° to 95° rotation
Electrical Protection	actuators are double insulated
Angle of Rotation	max. 95° (adjustable with mechanical end stop, 35° to 95°)
Torque	270 in-lbs [30 Nm] minimum
Direction of Rotation (Motor)	reversible with CW/CCW mounting
Direction of Rotation (Fail-Safe)	reversible with CW/CCW mounting
Position Indication	visual indicator, 0° to 95° (0° is full spring return position)
Manual Override	5 mm hex crank (3/16" Allen), supplied
Running Time (Motor)	75 sec
Running Time (Fail-Safe)	<20 sec @ -4°F to 122°F [-20°C to 50°C], < 60 sec @ -22°F [-30°C]
Humidity	100% condensing
Ambient Temperature Range	-22°F to +122°F [-30°C to +50°C]
Storage Temperature Range	-40°F to +176°F [-40°C to +80°C]
Housing	NEMA 4, IP66, UL enclosure type 4
Housing Material	Aluminum die cast and plastic casing
Agency Listings†	cULus acc. to UL60730-1A/-2-14, CAN/CSA E60730-1:02, CE acc. to 2004/108/EC and 2006/95/EC
Noise Level (Motor)	≤56.5 dB (A)
Noise Level (Fail-Safe)	≤71 dB (A)
Servicing	maintenance free
Quality Standard	ISO 9001
Auxiliary Switch	2 x SPDT 3A resistive (0.5A inductive) @ 250 VAC, one set at +10° and one set at 85°

†Rated Impulse Voltage 800V, Type of action 1.AA.B, Control Pollution Degree 4.

Torque min. 270 in-lb, for control of air dampers

Application

For On/Off, fail-safe control of dampers in HVAC systems. Actuator sizing should be done in accordance with the damper manufacturer's specifications. Control is On/Off from an auxiliary contact or a manual switch. The actuator is mounted directly to a damper shaft up to 1.05" in diameter by means of its universal clamp. A crank arm and several mounting brackets are available for applications where the actuator cannot be direct coupled to the damper shaft. Maximum of two EF's can be piggybacked for torque loads of up to 540 in-lbs. Minimum 3/4" diameter shaft and parallel wiring.

Operation

The EF.24-S N4 series actuators provide true spring return operation for reliable failsafe application and positive close off on air tight dampers. The spring return system provides constant torque to the damper with, and without, power applied to the actuator. The EF.24-S N4 series provides 95° of rotation and is provided with a graduated position indicator showing 0° to 95°. The actuator may be stalled anywhere in its normal rotation without the need of mechanical end switches. The EF.24-S N4 versions are provided with two built-in auxiliary switches. These SPDT switches are provided for safety interfacing or signaling, for example, for fan start-up. The switching function at the fail-safe position is fixed at +10°, the other switch function is fixed at 85°. The EF.24-S N4 actuator is shipped at +5° (5° from full fail-safe) to provide automatic compression against damper gaskets for tight shut-off.

Installation Note: Use 60°C/75°C copper (CU) conductor and wire size range 12-26 AWG, stranded or solid. If conduit is used, use flexible metal conduit; UL listed and CSA certified strain relief or conduit fitting suitable for outdoor applications, rated NEMA type 4, 4X, 6 or 6X or watertight.

Dimensions (Inches[mm])

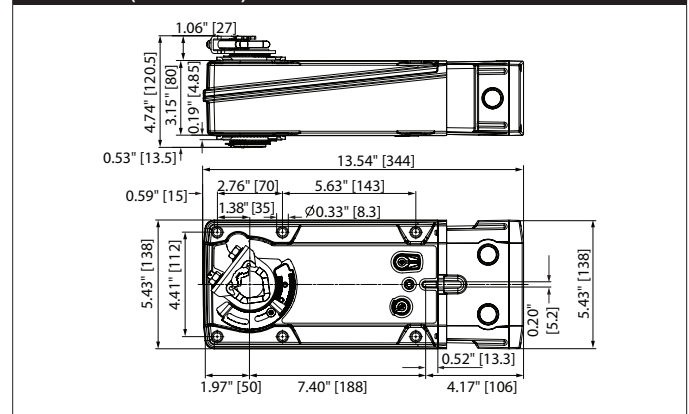

Accessories	
AV8-25	9.8" shaft extension for 5/16" to 1" diameter shafts.
EF-P	Anti-rotation bracket EFB(X)/GKB(X)/GMB(X).
IND-EFB	EFB(X) position indicator.
K9-2	Standard EFB(X) clamp (1/2" to 1.05").
KG10A	Ball joint for 3/8" diameter rod, zinc plated.
KH10	Univ. crankarm, slot 21/64" w, for 9/16" to 1" dia. shafts.
KH-EFB	EFB(X) crankarm (with 1.05" diameter shaft pass through).
SH10	Push rod for KG10A ball joint (36" L, 3/8" diameter).
TOOL-07	13 mm wrench.
ZG-100	Univ. right angle bracket (17" H x 11-1/8" W x 6" base).
ZG-120	Jackshaft mounting bracket.
ZG-DC1	Damper clip for damper blade, 3.5" width.
ZG-DC2	Damper clip for damper blade, 6" width.
ZG-EFB	EFB(X) crankarm adaptor kit.
ZG-JSA-3	1.05" diameter jackshaft adaptor (12" L).
PS-100	Actuator power supply and control simulator.
ZG-X40	120 to 24 VAC, 40 VA transformer.

Typical Specification

On/Off spring return damper actuators shall be direct coupled type which require no crank arm and linkage and be capable of direct mounting to a jackshaft up to a 1.05" diameter. The actuators must be designed so that they may be used for either clockwise or counter clockwise fail-safe operation. Actuators shall be protected from overload at all angles of rotation. If required, two SPDT auxiliary switch shall be provided. Actuators with auxiliary switches must be constructed to meet the requirements for Double Insulation so an electrical ground is not required to meet agency listings. Actuators shall be cULus listed and have a 5 year warranty, and be manufactured under ISO 9001 International Quality Control Standards. Actuators shall be as manufactured by Belimo.

Wiring Diagrams

- ⚠ WARNING! LIVE ELECTRICAL COMPONENTS!**
 During installation, testing, servicing and troubleshooting of this product, it may be necessary to work with live electrical components. Have a qualified licensed electrician or other individual who has been properly trained in handling live electrical components perform these tasks. Failure to follow all electrical safety precautions when exposed to live electrical components could result in death or serious injury.
- ◆ Meets cULus requirements without the need of an electrical ground connection.
 - ⚡ Apply only AC line voltage or only UL-Class 2 voltage to the terminals of auxiliary switches. Mixed or combined operation of line voltage/safety extra low voltage is not allowed.
 - 1 Provide overload protection and disconnect as required.
 - 3 Actuators may also be powered by 24 VDC.
 - 4 Two built-in auxiliary switches (2x SPDT), for end position indication, interlock control, fan startup, etc.
 - 16 Actuators are provided with a numbered screw terminal strip instead of a cable.
 - 45 Actuators may be powered in parallel. Power consumption must be observed.
 - 48 Parallel wiring required for piggy-back applications.

