

# EV150S-396, 1-1/2", Energy Valve

## Stainless Steel Ball and Stem, Female NPT Ends

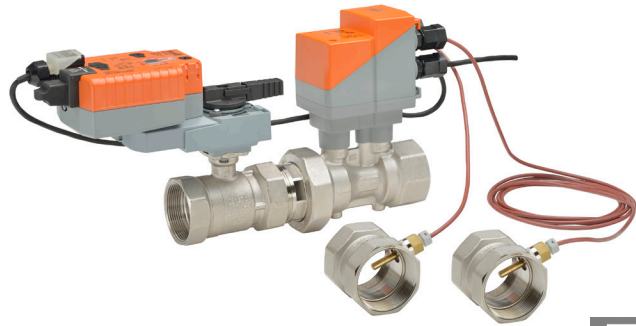

### Technical Data

Service	chilled or hot water, up to 60% glycol max (open loop/steam not allowed)
Flow Characteristic	equal percentage or linear
GPM Range	11.9-39.6
Size [mm]	1.5" [40]
End Fitting	npt female ends
Body	forged brass, nickel plated
Sensor Housing	forged brass, nickel plated
Ball	stainless steel
Stem	stainless steel
Stem Packing	EPDM (lubricated)
Seat	Teflon® PTFE
Seat O-ring	EPDM
Characterized Disc	TEFZEL®
Body Pressure Rating [psi]	360
Media Temperature Range (Water)	14°F to 250°F [-10°C to 120°C]
Differential Pressure Range	5 to 50 psid or 1 to 50 psid see flow reductions chart in tech doc
Close-Off Pressure	200 psi
Inlet Length to Meet Specified Measurement Accuracy	5X nominal pipe size (NPS)
Ambient Humidity	<95% RH non-condensing
Flow Measurement Tolerance	±2%*
Flow Control Tolerance	±5%
Flow Measurement Repeatability	+/- 0.5%
Sensor Technology	ultrasonic with glycol and temperature compensation
Temperature Sensors	PT1000 insertion sensors
Temperature Measurement Tolerance	According to PT1000 DIN EN60751 ClassB
Resolution of Temperature Sensor	0.18°F (0.1°C)
Rated Impulse Voltage	actuator/sensor: 0.8 kV (in accordance with EN60730-1) kV
Weight	9.9 lb [4.5 kg]
Remote Temperature Sensor Length	Standard: 2 ft. 7.5 in. [0.8m], 9.8 ft. [3m]
Leakage	0%
Degree of Protection IEC/EN	IP54
Degree of Protection NEMA/ UL	NEMA 1, UL Enclosure Type 1
Glycol Measurement Accuracy	+/-5%

\*All flow tolerances are at 68°F (20°C) & water.

### Application

Water-side control of heating and cooling systems for AHUs and water coils. Equal Percentage/ Linear: heating and cooling applications.

### Operation

The Energy Valve is an energy metering pressure independent control valve that measures, documents and optimizes water coil performance.

### Product Features

The Energy Valve measures energy using its built-in electronic flow sensor and supply and return temperature sensors. Controls power with its Power Control logic providing linear heat transfer regardless of temperature and pressure variations. Manages Low Delta T Syndrome with its built in Delta T Manager. Measures glycol with advanced algorithms in its built in flow sensor. An IoT device utilizing cloud-based technology to optimize performance.

### Suitable Actuators

	Non-Spring	Electronic Fail-Safe
EV150S-396	NRB(X)	AKRB(X)

### Dimensions (Inches [mm])

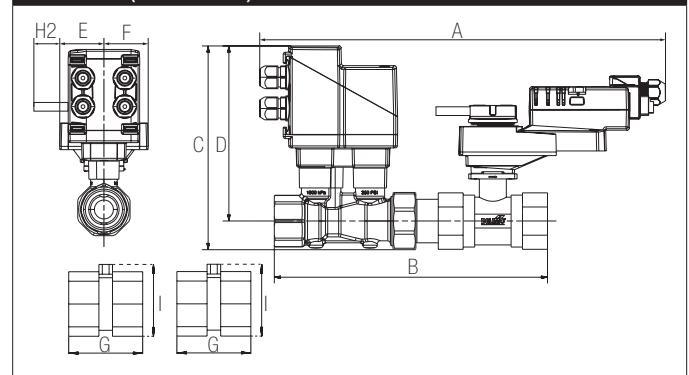

A	B	C	D	E	F	G	H2	I
16.84" [428]	10.78" [274]	7.87" [200]	6.77" [172]	1.73" [44]		2.77" [70.5]	0.75" [20]	3.7" [94]

# AKRX24-EV

Modulating, Electronic Fail-Safe, 24 V, Shared Logic Technology®



Technical Data	
Power Supply	24 VAC ± 20%, 50/60 Hz, 24 VDC ± 10%
Power Consumption Running	14 W (0.5" to 2"), 16 W (2.5" to 6")
Transformer Sizing	23 VA (0.5" to 2"), 26 VA (2.5" to 6") (class 2 power source)
Electrical Connection	18 GA plenum rated cable and RJ45 socket (ethernet)
Overload Protection	electronic throughout 0° to 90° rotation
Operating Range Y	2 to 10 VDC (default) VDC variable
Input Impedance	100 kΩ (0.1 mA), 500 Ω
Feedback Output U	2 to 10 VDC (default) VDC variable
Angle of Rotation	90°
Direction of Rotation (Motor)	reversible with web view
Direction of Rotation (Fail-Safe)	reversible with switch
Position Indication	integrated into handle
Manual Override	external push button
Running Time (Motor)	90 sec
Running Time (Fail-Safe)	35 sec
Ambient Humidity	<95% RH non-condensing
Ambient Temperature Range	-22°F to 122°F [-30°C to 50°C]
Storage Temperature Range	-40°F to 176°F [-40°C to 80°C]
Housing	NEMA 1, IP54, UL Enclosure Type 1
Housing Material	UL94-5VA
Agency Listings†	cULus acc. to UL60730-1A/-2-14, CAN/CSA E60730-1:02, CE acc. to 2004/108/EC and 2006/95/EC
Noise Level (Motor)	max. 45 dB (A)
Servicing	maintenance free
Quality Standard	ISO 9001
Weight	3.3 lb [1.5 kg]
Communication	BACnet IP, BACnet MS/TP, listed by BTL, Modbus RTU, Modbus IP, web server, Belimo MP-Bus

The Energy Valve is based on Belimo patent and patent pending technology, US-Patent 6,039,304: Ball valve with modified characteristics, US-Patent Pending: 2011/0153089: HVAC actuator comprising a network interface, data store and a processor, US-Patent Pending: 2009/009115: Control of sensor less and brushless DC-Motor.

The Energy Valve incorporates additional technology - Powered by Optimum Energy TM.

Date created, 08/31/2017 - Subject to change. © Belimo Aircontrols (USA), Inc.

**Wiring Diagrams**
**INSTALLATION NOTES**

- Actuators with appliance cables are numbered.
- Actuators may be connected in parallel. Power consumption and input impedance must be observed.
- Actuators may also be powered by 24 VDC.
- Actuators with plenum cable do not have numbers; use color codes instead.
- Meets cULus requirements without the need of an electrical ground connection.

**WARNING! LIVE ELECTRICAL COMPONENTS!**  
 During installation, testing, servicing and troubleshooting of this product, it may be necessary to work with live electrical components. Have a qualified licensed electrician or other individual who has been properly trained in handling live electrical components perform these tasks. Failure to follow all electrical safety precautions when exposed to live electrical components could result in death or serious injury.

