

# EV250S-127-250, ANSI 250 Energy Valve

Cast Iron Body, Stainless Steel Trim



### Technical Data

Service	chilled or hot water, up to 60% glycol max (open loop/steam not allowed)
Flow Characteristic	equal percentage or linear
Controllable Flow Range	stem up - open A to AB
GPM Range	38-127
Size [mm]	2.5" [65]
End Fitting	250 lb flanged
Body	cast iron - ASTM A126 Class B
Sensor Housing	ductile iron - GGG50
Stem	316 stainless steel
Stem Packing	NLP EPDM (no lip packing)
Seat	316 stainless steel
Plug	stainless steel
Body Pressure Rating [psi]	ANSI 250
Number of Bolt Holes	8
Max Inlet Pressure (Water)	300 psi (2068 kPa) @ 250°F [121°C]
Media Temperature Range (Water)	14°F to 250°F [-10°C to 120°C]
Conductivity of Fluid	Min. 20uS/cm
Differential Pressure Range	7.5 to 50 psid or 1 to 50 psid with flow reductions
Max Differential Pressure (Water)	50 psi (345 kPa)
Inlet Length to Meet Specified Measurement Accuracy	5X nominal pipe size (NPS)
Flow Measurement Tolerance	±2%*
Flow Control Tolerance	±5%
Flow Measurement Repeatability	±0.5%
Sensor Technology	electromagnetic
Temperature Sensors	PT1000 insertion sensors with thermal well
Resolution of Temperature Sensor	0.18°F (0.1°C)
Weight	119 lb [54 kg]
Rated Impulse Voltage	actuator/sensor: 0.8kV (in accordance w/ EN 60730-1)
Remote Temperature Sensor Length	Optional: 4.9 ft. [1.5m], 9.8 ft. [3m], 16.4 ft. [5m] Standard: 32.8 ft. [10m]
Manual Override	5 mm hex crank (3/16" Allen), supplied
Leakage	ANSI Class IV
Servicing	Repack/Rebuild kits available
Degree of Protection IEC/EN	IP54
Degree of Protection NEMA/ UL	NEMA 1, UL Enclosure Type 1

### Application

Water-side control of heating and cooling systems for AHUs and water coils. Equal Percentage/ Linear: heating and cooling applications.

### Operation

The Energy Valve is an energy metering pressure independent control valve that measures, documents and optimizes water coil performance.

### Product Features

The Energy Valve measures energy using its built-in electronic flow sensor and supply and return temperature sensors. Controls power with its Power Control logic providing linear heat transfer regardless of temperature and pressure variations. Manages Low Delta T Syndrome with its built in Delta T Manager. Measures glycol with advanced algorithms in its built in flow sensor. An IoT device utilizing cloud-based technology to optimize performance.

### Suitable Actuators

	Non-Spring	Electronic Fail-Safe
EV250S-127-250	EVX	AVKX

### Dimensions (Inches [mm])

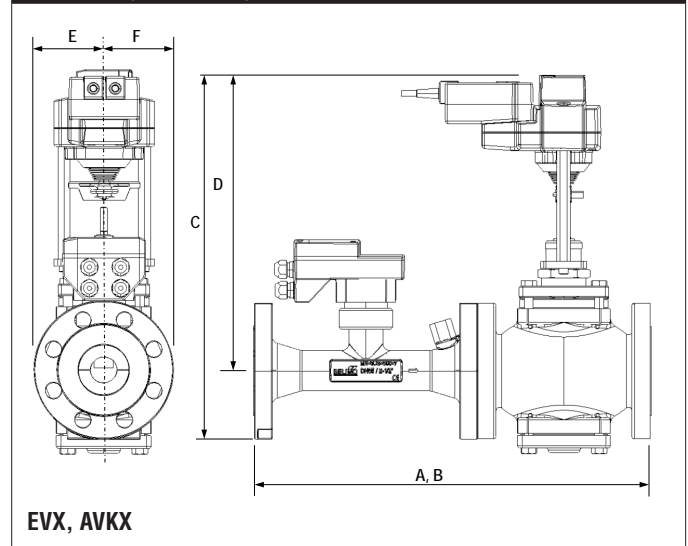

A	B	C	D	E	F
22.2" [564]		20.4" [516]	18.25" [464]	4.5" [114]	4.5" [114]

### Piping

The valves should be mounted in a weather-protected area in a location that is within the ambient limits of the actuator. Allow sufficient room for valve with actuator and for service. The preferred mounting position of the valve is with the valve stem vertical above the valve body, for maximum life. However, the assemblies can be mounted with valve stem vertical above the valve or up to 45 degrees in relation to the horizontal pipe. The actuators should never be mounted underneath the valve, as condensation can build up and result in a failure of the actuators. Do not reverse flow direction.

Date created, 08/31/2017 - Subject to change. © Belimo Aircontrols (USA), Inc.



## EV250S-127-250, ANSI 250 Energy Valve Cast Iron Body, Stainless Steel Trim

\*All flow tolerances are at 68°F (20°C) & water.

Date created, 08/31/2017 - Subject to change. © Belimo Aircontrols (USA), Inc.

# EVX24-EV-L

Modulating, Non-Spring Return, 24 V, Shared Logic Technology®



Technical Data	
Power Supply	24 VAC ± 20%, 50/60 Hz, 24 VDC ± 10%
Power Consumption Running	5 W
Power Consumption Holding	1.5 W
Transformer Sizing	7.5 VA (class 2 power source)
Electrical Connection	18 GA plenum rated cable and RJ45 socket (ethernet)
Overload Protection	electronic throughout full stroke
Electrical Protection	actuators are double insulated
Operating Range Y	2 to 10 VDC (default) VDC variable
Input Impedance	100 kΩ (0.1 mA), 500 Ω
Feedback Output U	2 to 10 VDC (default) VDC variable
Direction of Rotation (Motor)	reversible with built-in switch
Position Indication	stroke indicator on bracket
Manual Override	5 mm hex crank (3/16" Allen), supplied
Running Time (Motor)	90 sec, constant independent of load
Ambient Humidity	<95% RH non-condensing
Ambient Temperature Range	-22°F to 122°F [-30°C to 50°C]
Storage Temperature Range	-40°F to 176°F [-40°C to 80°C]
Housing	NEMA 1, IP54, UL Enclosure Type 1
Housing Material	Aluminum die cast and plastic casing
Agency Listings†	cULus acc. to UL60730-1A/-2-14, CAN/CSA E60730-1:02, CE acc. to 2004/108/EC and 2006/95/EC
Noise Level (Motor)	<60 dB (A)
Servicing	maintenance free
Quality Standard	ISO 9001
Weight	5.7 lb [2.6 kg]
Communication	BACnet IP, BACnet MS/TP, listed by BTL, Modbus RTU, Modbus IP, web server, Belimo MP-Bus

† Use flexible metal conduit. Push the listed conduit fitting device over the actuator's cable to butt against the enclosure. Screw in conduit connector. Jacket the actuators input wiring with listed flexible conduit. Properly terminate the conduit in a suitable junction box. Rated impulse Voltage 800V. Type of action 1. Control pollution degree 3.

In cases where the valve body is electrically isolated from the water pipe, an earth ground should be installed in order for the sensor to work properly. Earth ground can be connected directly on the sensor body. A connection point is provided on the flange of the sensor body.

The Energy Valve is based on Belimo patent and patent pending technology, US-Patent 6,039,304: Ball valve with modified characteristics, US-Patent Pending: 2011/0153089: HVAC actuator comprising a network interface, data store and a processor, US-Patent Pending: 2009/009115: Control of sensor less and brushless DC-Motor.  
The Energy Valve incorporates additional technology - Powered by Optimum Energy TM.

Date created, 08/31/2017 - Subject to change. © Belimo Aircontrols (USA), Inc.

**Wiring Diagrams**
**INSTALLATION NOTES**

- Actuators with appliance cables are numbered.
- Actuators may be connected in parallel. Power consumption and input impedance must be observed.
- Actuators may also be powered by 24 VDC.
- Actuators with plenum cable do not have numbers; use color codes instead.
- Meets cULus requirements without the need of an electrical ground connection.

**WARNING! LIVE ELECTRICAL COMPONENTS!**  
 During installation, testing, servicing and troubleshooting of this product, it may be necessary to work with live electrical components. Have a qualified licensed electrician or other individual who has been properly trained in handling live electrical components perform these tasks. Failure to follow all electrical safety precautions when exposed to live electrical components could result in death or serious injury.

