

EV500S-495, 5", Energy Valve

Stainless Steel Ball, ANSI 125 Flange

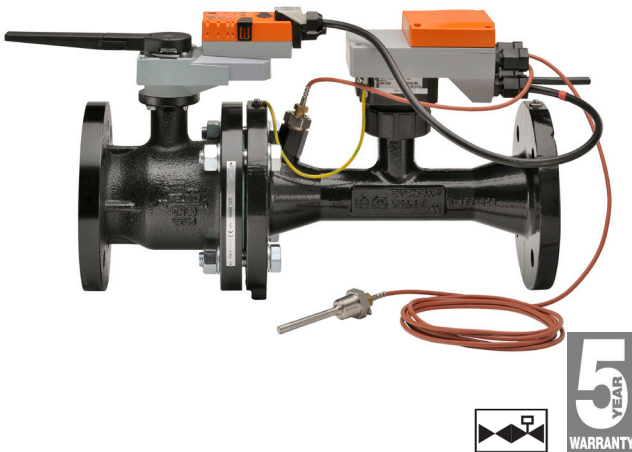

Technical Data

| | |
|---|---|
| Service | chilled or hot water, up to 60% glycol max (open loop/steam not allowed) |
| Flow Characteristic | equal percentage or linear |
| GPM Range | 149-495 |
| Size [mm] | 5" [125] |
| End Fitting | pattern to mate with ansi 125 flange |
| Body | cast iron - GG25 |
| Sensor Housing | ductile iron - GGG50 |
| Ball | stainless steel |
| Stem | stainless steel |
| Stem Packing | EPDM (lubricated) |
| Seat | PTFE |
| Characterized Disc | stainless steel |
| Body Pressure Rating [psi] | ANSI 125, standard class B |
| Media Temperature Range (Water) | 14°F to 250°F [-10°C to 120°C] |
| Conductivity of Fluid | Min. 20uS/cm |
| Differential Pressure Range | 5 to 50 psid or 1 to 50 psid see flow reductions chart in tech doc |
| Close-Off Pressure | 100 psi |
| Inlet Length to Meet Specified Measurement Accuracy | 5X nominal pipe size (NPS) |
| Ambient Humidity | <95% RH non-condensing |
| Flow Measurement Tolerance | ±2%* |
| Flow Control Tolerance | ±5% |
| Flow Measurement Repeatability | +/- 0.5% |
| Sensor Technology | electromagnetic |
| Temperature Sensors | PT1000 insertion sensors with thermal well |
| Temperature Measurement Tolerance | According to PT1000 DIN EN60751 ClassB |
| Resolution of Temperature Sensor | 0.18°F (0.1°C) |
| Rated Impulse Voltage | actuator/sensor: 0.8 kV (in accordance with EN60730-1) kV |
| Weight | 119 lb [54 kg] |
| Remote Temperature Sensor Length | Optional: 4.9 ft. [1.5m], 9.8 ft. [3m], 16.4 ft. [5m] Standard: 32.8 ft. [10m] |
| Leakage | 0% |
| Degree of Protection IEC/EN | IP54 |
| Degree of Protection NEMA/ UL | NEMA 1, UL Enclosure Type 1 |

*All flow tolerances are at 68°F (20°C) & water.

Application

Water-side control of heating and cooling systems for AHUs and water coils. Equal Percentage/ Linear: heating and cooling applications.

Operation

The Energy Valve is an energy metering pressure independent control valve that measures, documents and optimizes water coil performance.

Product Features

The Energy Valve measures energy using its built-in electronic flow sensor and supply and return temperature sensors. Controls power with its Power Control logic providing linear heat transfer regardless of temperature and pressure variations. Manages Low Delta T Syndrome with its built in Delta T Manager. Measures glycol with advanced algorithms in its built in flow sensor. An IoT device utilizing cloud-based technology to optimize performance.

Suitable Actuators

| | Non-Spring | Electronic Fail-Safe |
|------------|------------|----------------------|
| EV500S-495 | GRB(X) | GKRB(X) |

Dimensions (Inches [mm])

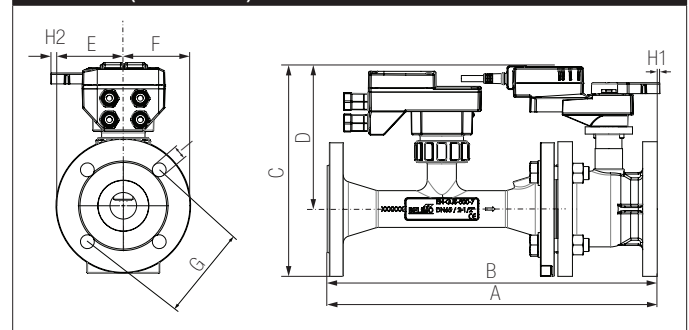

| A | B | C | D | E | F | G | H1 | H2 | I |
|--------------|---|-------------|------------|----------|---|------------|------------|-----------|------------|
| 25.18" [640] | | 14.4" [366] | 9.4" [239] | 5" [127] | | 8.5" [216] | 2.07" [53] | 1.3" [33] | 0.88" [22] |

GKRB24-EV

Modulating, Electronic Fail-Safe, 24 V, Shared Logic Technology®



Technical Data

| | |
|-----------------------------------|--|
| Power Supply | 24 VAC ± 20%, 50/60 Hz, 24 VDC ± 10% |
| Power Consumption Running | 17 W |
| Transformer Sizing | 29 VA (class 2 power source) |
| Electrical Connection | 18 GA plenum rated cable and RJ45 socket (ethernet) |
| Overload Protection | electronic throughout 0° to 90° rotation |
| Operating Range Y | 2 to 10 VDC (default) VDC variable |
| Input Impedance | 100 kΩ (0.1 mA), 500 Ω |
| Feedback Output U | 2 to 10 VDC (default) VDC variable |
| Angle of Rotation | 90° |
| Direction of Rotation (Motor) | reversible with web view |
| Direction of Rotation (Fail-Safe) | reversible with switch |
| Position Indication | integrated into handle |
| Manual Override | external push button |
| Running Time (Motor) | 90 sec |
| Running Time (Fail-Safe) | 35 sec |
| Ambient Humidity | <95% RH non-condensing |
| Ambient Temperature Range | -22°F to 122°F [-30°C to 50°C] |
| Storage Temperature Range | -40°F to 176°F [-40°C to 80°C] |
| Housing | NEMA 1, IP54, UL Enclosure Type 1 |
| Housing Material | UL94-5VA |
| Agency Listings† | cULus acc. to UL60730-1A/-2-14, CAN/CSA E60730-1:02, CE acc. to 2004/108/EC and 2006/95/EC |
| Noise Level (Motor) | max. 45 dB (A) |
| Noise Level (Fail-Safe) | <45 dB (A) |
| Servicing | maintenance free |
| Quality Standard | ISO 9001 |
| Weight | 5.5 lb [2.5 kg] |
| Communication | BACnet IP, BACnet MS/TP, listed by BTL, Modbus RTU, Modbus IP, web server, Belimo MP-Bus |

The Energy Valve is based on Belimo patent and patent pending technology, US-Patent 6,039,304: Ball valve with modified characteristics, US-Patent Pending: 2011/0153089: HVAC actuator comprising a network interface, data store and a processor, US-Patent Pending: 2009/009115: Control of sensor less and brushless DC-Motor.

The Energy Valve incorporates additional technology - Powered by Optimum Energy TM.

Date created, 08/31/2017 - Subject to change. © Belimo Aircontrols (USA), Inc.

Wiring Diagrams
INSTALLATION NOTES

- Actuators with appliance cables are numbered.
- Actuators may be connected in parallel. Power consumption and input impedance must be observed.
- Actuators may also be powered by 24 VDC.
- Actuators with plenum cable do not have numbers; use color codes instead.
- Meets cULus requirements without the need of an electrical ground connection.

WARNING! LIVE ELECTRICAL COMPONENTS!
 During installation, testing, servicing and troubleshooting of this product, it may be necessary to work with live electrical components. Have a qualified licensed electrician or other individual who has been properly trained in handling live electrical components perform these tasks. Failure to follow all electrical safety precautions when exposed to live electrical components could result in death or serious injury.

