

# G212S, 2-Way, Globe Valve, Stainless Steel Trim

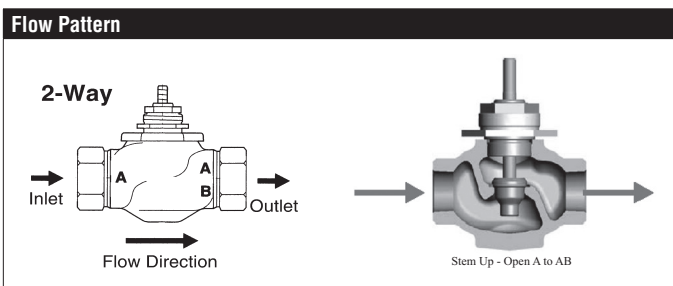

Technical Data	
Service	chilled or hot water, up to 60% glycol, steam
Flow Characteristic	linear
Controllable Flow Range	stem up - open A to AB
Size [mm]	0.5" [15]
End Fitting	NPT female ends
Body	bronze
Stem	316 stainless steel
Stem Packing	spring loaded Teflon® V-ring
Seat	316 stainless steel
Plug	316 stainless steel
Disc	Teflon
Body Pressure Rating [psi]	ANSI 250
ANSI Class	ANSI 250 ( up to 400 psi below 150°F)
Max Inlet Pressure (Steam)	100 psi (690 kPa)
Media Temperature Range (Water)	20°F to 280°F [-7°C to 138°C]
Media Temperature Range (Steam)	32°F to 338°F [0°C to 170°C]
Maximum Differential Pressure (Steam)	35 psi
Max Differential Pressure (Water)	35 psi (241 kPa)
Rangeability	15:1
Cv	0.4
Weight	1.5 lb [0.7 kg]
Leakage	ANSI Class IV
Servicing	Repack/Rebuild kits available



## Application

This valve is typically used in Air handling units on heating or cooling coils, and fan coil unit heating or cooling coils. Some other common applications include Unit Ventilators, VAV box re-heat coils and bypass loops. This valve is suitable for use in hydronic system with variable flow. Bronze and stainless steel trim valves can be used for steam applications, depending on actuator and close-off combinations.

## Suitable Actuators

	Non-Spring	Spring	Electronic Fail-Safe
G212S	LVB(X)	LF	LVKB(X)

## Dimensions (Inches [mm])

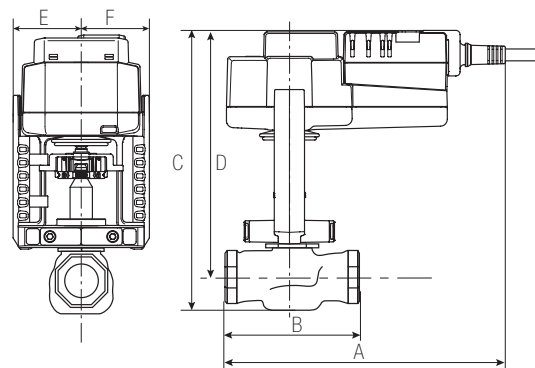

LVB, LVX SVB, SVX

A	B	C	D	E	F
7.8" [200]	3.07" [78]	8.75" [222]	7.81" [198]	1.95" [49]	

## Piping

The valves should be mounted in a weather-protected area in a location that is within the ambient limits of the actuator. Allow sufficient room for valve with actuator and for service. The G2(S) and G3(D) preferred mounting position of the valve is with the valve stem vertical above the valve body, for maximum life. However, the assemblies can be mounted with the valve stem vertical or horizontal in relation to the pipe. The actuators should never be mounted underneath the valve, as condensation can build up and result in a failure of the actuators. Do not reverse flow direction.

## G212S, 2-Way, Globe Valve, Stainless Steel Trim

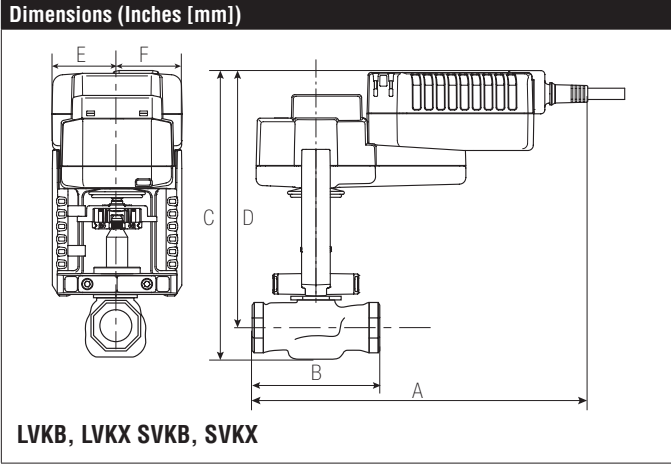

A	B	C	D	E	F
8.2" [209]	3.07" [78]	8.95" [227]	7.81" [198]	1.95" [49]	

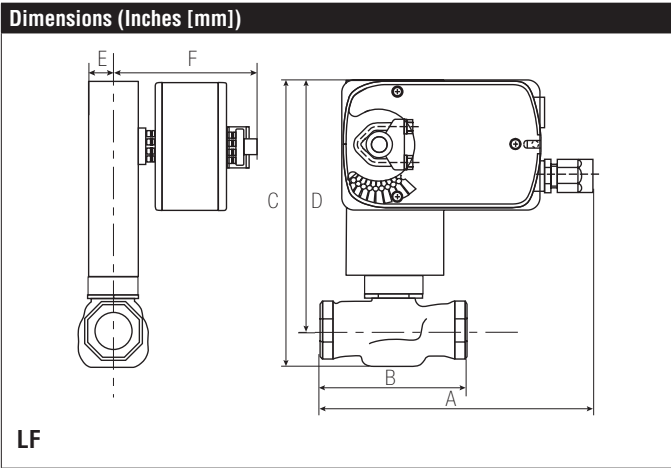

A	B	C	D	E	F
8.1" [206]	3.07" [78]	8.7" [219]	7.79" [198]	1" [25]	5.3" [135]

# LF24-MFT US, Valve Actuator

Modulating, Spring Return, Multi-Function Technology®



Technical Data	
Power Supply	24 VAC ± 20%, 50/60 Hz, 24 VDC ± 10%
Power Consumption Running	2.5 W
Power Consumption Holding	1 W
Transformer Sizing	5 VA (class 2 power source)
Electrical Connection	3ft [1m], 18 GA appliance cable with 1/2" conduit connector
Overload Protection	electronic throughout 0° to 95° rotation
Operating Range Y	2 to 10 VDC, 4 to 20 mA w/ ZG-R01 (500 Ω, 1/4 W resistor), variable (VDC, floating point, on/off)
Input Impedance	100 k Ω for 2 to 10 VDC (0.1 mA), 500 Ω for 4 to 20 mA, 1500 Ω for PWM, floating point and On/Off
Feedback Output U	2 to 10 VDC, 0.5 mA max, VDC variable
Angle of Rotation	90°
Direction of Rotation (Motor)	reversible with built-in switch
Direction of Rotation (Fail-Safe)	reversible with CW/CCW mounting
Position Indication	visual indicator, 0° to 95° (0° is full spring return position)
Running Time (Motor)	150 sec (default), variable (75 to 300 sec)
Running Time (Fail-Safe)	<25 sec @ -4°F to 122°F [-20°C to 50°C], < 60 sec @ -22°F [-30°C]
Ambient Temperature Range	-22°F to 122°F [-30°C to 50°C]
Storage Temperature Range	-40°F to 176°F [-40°C to 80°C]
Housing	NEMA 2, IP54
Agency Listings†	cULus acc. To UL 873 and CAN/CSA C22.2 No. 24-93
Noise Level (Motor)	<50 dB (A)
Noise Level (Fail-Safe)	<62 dB (A)
Servicing	maintenance free
Quality Standard	ISO 9001

†Rated Impulse Voltage 800V, Type of action 1.AA, Control Pollution Degree 3  
 \*Variable when configured with MFT options.

Date created, 09/05/2017 - Subject to change. © Belimo Aircontrols (USA), Inc.

## Wiring Diagrams

### INSTALLATION NOTES

- Actuators with appliance cables are numbered.
- Provide overload protection and disconnect as required.
- Actuators may be connected in parallel. Power consumption and input impedance must be observed.
- Apply only AC line voltage or only UL-Class 2 voltage to the terminals of auxiliary switches. Mixed or combined operation of line voltage/safety extra low voltage is not allowed.
- Actuators may also be powered by 24 VDC.
- Two built-in auxiliary switches (2x SPDT), for end position indication, interlock control, fan startup, etc.
- Only connect common to negative (-) leg of control circuits.
- A 500 Ω resistor (ZG-R01) converts the 4 to 20 mA control signal to 10 VDC.
- Control signal may be pulsed from either the Hot (Source) or Common (Sink) 24 VAC line.
- For triac sink the Common connection from the actuator must be connected to the Hot connection of the controller. Position feedback cannot be used with a triac sink controller; the actuator internal common reference is not compatible.
- Actuators may be connected in parallel if not mechanically linked. Power consumption and input impedance must be observed.
- IN4004 or IN4007 diode. (IN4007 supplied, Belimo part number 40155).
- Meets cULus requirements without the need of an electrical ground connection.
- Actuators are provided with color coded wires. Wire numbers are provided for reference.
- WARNING! LIVE ELECTRICAL COMPONENTS!** During installation, testing, servicing and troubleshooting of this product, it may be necessary to work with live electrical components. Have a qualified licensed electrician or other individual who has been properly trained in handling live electrical components perform these tasks. Failure to follow all electrical safety precautions when exposed to live electrical components could result in death or serious injury.

**On/Off**

**Floating Point**

**VDC/mA Control**

**PWM Control**

**Override Control**

Functions	a	b	c
Min	0% ←	↗	↘
Mid	50% ←	↗	↘
Max	100% ←	↗	↘
Normal	Control mode acc. to Y	↗	↘