

G225, 2-Way, Globe Valve, Bronze Trim



Technical data

Service	chilled or hot water, up to 60% glycol, steam
Flow Characteristic	equal percentage
Controllable Flow Range	stem up - open A to AB
Size [mm]	1" [25]
End Fitting	NPT female ends
Body	bronze
Stem	stainless steel
Stem Packing	spring loaded Teflon V-ring
Seat	bronze
Plug	brass
Disc	composition (EPDM)
Body Pressure Rating [psi]	ANSI 250
ANSI Class	ANSI 250 (up to 400 psi below 150°F)
Max Inlet Pressure (Steam)	35 psi (241 kPa)
Media Temperature Range (Water)	20°F to 280°F [-7°C to 138°C]
Media Temperature Range (Steam)	32°F to 280°F [0°C to 138°C]
Maximum differential pressure (steam)	20 psi (103 kPa)
Max Differential Pressure (Water)	35 psi (241 kPa)
Leakage	ANSI Class IV
Rangeability	75:1
Cv	14
Weight	3.1 lb [1.4 kg]
Servicing	Repack/Rebuild kits available

Flow Pattern

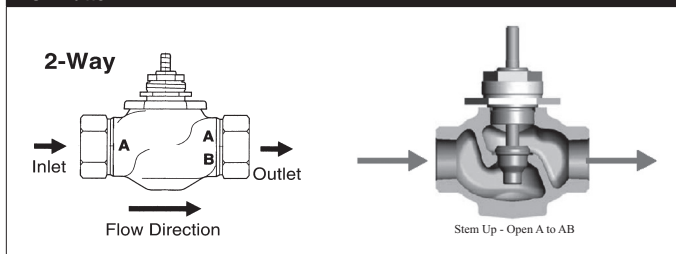

Application

This valve is typically used in Air handling units on heating or cooling coils, and fan coil unit heating or cooling coils. Some other common applications include Unit Ventilators, VAV box re-heat coils and bypass loops. This valve is suitable for use in hydronic system with variable flow. Bronze and stainless steel trim valves can be used for steam applications, depending on actuator and close-off combinations.

Suitable Actuators

	Non-Spring	Spring	Electronic Fail-Safe
G225	SVB(X)	NFB(X)	SVKB(X)

Dimensions (Inches [mm])

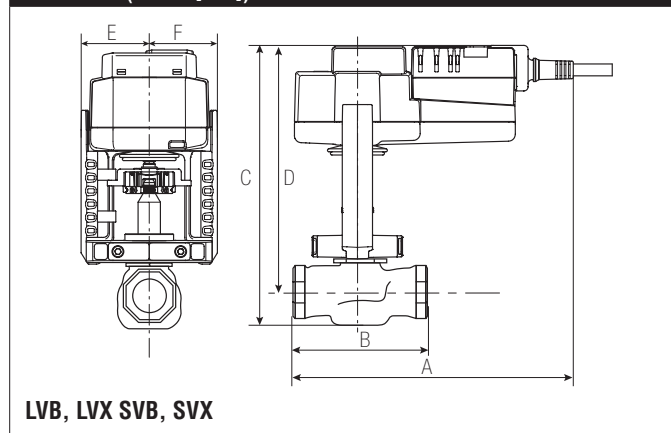

A	B	C	D	E	F
8" [203]	4.65" [118]	9.5" [241]	8.35" [212]	1.95" [49]	

Piping

The valves should be mounted in a weather-protected area in a location that is within the ambient limits of the actuator. Allow sufficient room for valve with actuator and for service. The G2(S) and G3(D) preferred mounting position of the valve is with the valve stem vertical above the valve body, for maximum life. However, the assemblies can be mounted with the valve stem vertical or horizontal in relation to the pipe. The actuators should never be mounted underneath the valve, as condensation can build up and result in a failure of the actuators. Do not reverse flow direction.

G225, 2-Way, Globe Valve, Bronze Trim

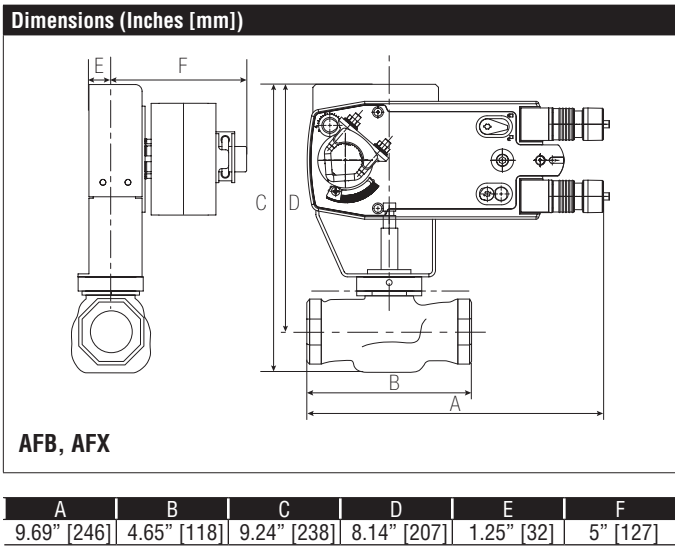
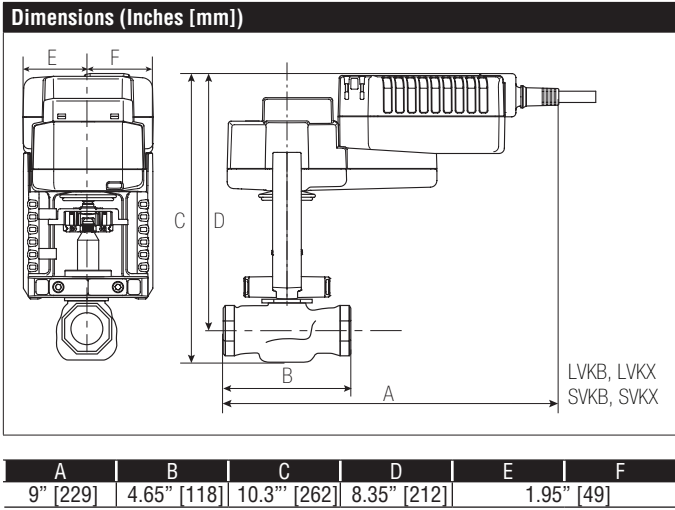

NFB24-SR-X1

Modulating, Spring Return, 24 VAC/DC, for 2 to 10 VDC or 4 to 20 mA Control Signal



Technical Data	
Power Supply	24 VAC±20%, 50/60Hz, 24 VDC+20%/-10%
Power Consumption Running	3.5 W
Power Consumption Holding	2.5 W
Transformer Sizing	6 VA (class 2 power source)
Shaft Diameter	1/2" to 1.05" round, centers on 1/2" and 3/4" with insert, 1.05" without insert
Electrical Connection	3 ft [1 m], 18 GA appliance cable with 1/2" conduit connector
Overload Protection	electronic throughout 0° to 95° rotation
Operating Range	2 to 10 VDC, 4 to 20 mA (default)
Position Feedback	2 to 10 VDC, 0.5 mA max
Angle of Rotation	95° (adjustable with mechanical end stop, 35° to 95°)
Torque	90 in-lbs [10 Nm] minimum
Direction of Rotation (Motor)	reversible with built-in switch
Direction of Rotation (Fail-Safe)	reversible with CW/CCW mounting
Position Indication	visual indicator, 0° to 95° (0° is full spring return position)
Manual Override	5 mm hex crank (3/16" Allen), supplied
Running Time (Motor)	95 sec
Running Time (Fail-Safe)	<20 sec @ -4°F to 122°F [-20°C to 50°C], < 60 sec @ -22°F [-30°C]
Humidity	max. 95% RH non-condensing
Ambient Temperature Range	-22°F to 122°F [-30°C to 50°C]
Storage Temperature Range	-40°F to 176°F [-40°C to 80°C]
Housing	NEMA 2, IP54, UL enclosure type 2
Housing Material	zinc coated metal and plastic casing
Agency Listings†	cULus acc. to UL60730-1A/-2-14, CAN/CSA E60730-1:02, CE acc. to 2004/108/EC and 2006/95/EC
Sound power level	<50 dB (A)
Noise Level (Fail-Safe)	<62 dB (A)
Servicing	maintenance free
Quality Standard	ISO 9001
Weight	4.2 lb [1.9 kg]

†Rated Impulse Voltage 800V, Type of Action 1.AA.B, Control Pollution Degree 3.

Date created, 04/08/2016 - Subject to change. © Belimo Aircontrols (USA), Inc.

Wiring Diagrams
INSTALLATION NOTES

- Actuators with appliance cables are numbered.
- Provide overload protection and disconnect as required.
- Actuators may also be powered by 24 VDC.
- Only connect common to negative (-) leg of control circuits.
- A 500 Ω resistor (ZG-R01) converts the 4 to 20 mA control signal to 2 to 10 VDC.
- Actuators may be connected in parallel if not mechanically linked. Power consumption and input impedance must be observed.

APPLICATION NOTES

- Meets cULus requirements without the need of an electrical ground connection.

WARNING! LIVE ELECTRICAL COMPONENTS!
 During installation, testing, servicing and troubleshooting of this product, it may be necessary to work with live electrical components. Have a qualified licensed electrician or other individual who has been properly trained in handling live electrical components perform these tasks. Failure to follow all electrical safety precautions when exposed to live electrical components could result in death or serious injury.

