

# G240, 2-Way, Globe Valve, Bronze Trim



### Technical data

Service	chilled or hot water, up to 60% glycol, steam
Flow Characteristic	equal percentage
Controllable Flow Range	stem up - open A to AB
Size [mm]	1.5" [40]
End Fitting	NPT female ends
Body	bronze
Stem	stainless steel
Stem Packing	spring loaded Teflon V-ring
Seat	bronze
Plug	brass
Disc	composition (EPDM)
Body Pressure Rating [psi]	ANSI 250
ANSI Class	ANSI 250 ( up to 400 psi below 150°F)
Max Inlet Pressure (Steam)	35 psi (241 kPa)
Media Temperature Range (Water)	20°F to 280°F [-7°C to 138°C]
Media Temperature Range (Steam)	32°F to 280°F [0°C to 138°C]
Maximum differential pressure (steam)	20 psi (103 kPa)
Max Differential Pressure (Water)	35 psi (241 kPa)
Leakage	ANSI Class IV
Rangeability	75:1
Cv	28
Weight	5.7 lb [2.6 kg]
Servicing	Repack/Rebuild kits available

### Flow Pattern

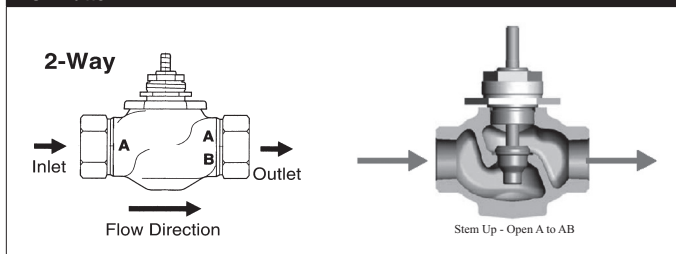

### Application

This valve is typically used in Air handling units on heating or cooling coils, and fan coil unit heating or cooling coils. Some other common applications include Unit Ventilators, VAV box re-heat coils and bypass loops. This valve is suitable for use in hydronic system with variable flow. Bronze and stainless steel trim valves can be used for steam applications, depending on actuator and close-off combinations.

### Suitable Actuators

	Non-Spring	Spring	Electronic Fail-Safe
G240	SVB(X)	AFB(X)	SVKB(X)

### Dimensions (Inches [mm])

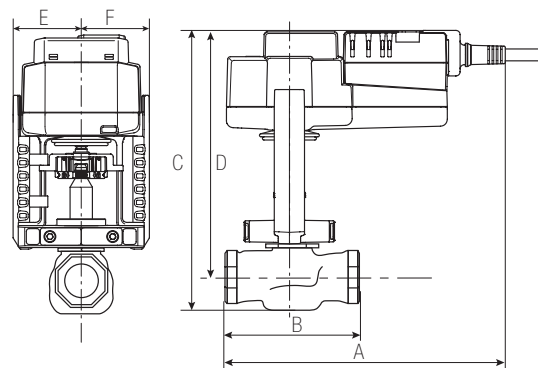

LVB, LVX SVB, SVX

A	B	C	D	E	F
9" [229]	5.39" [137]	10" [252]	8.5" [216]	1.95" [49]	

### Piping

The valves should be mounted in a weather-protected area in a location that is within the ambient limits of the actuator. Allow sufficient room for valve with actuator and for service. The G2(S) and G3(D) preferred mounting position of the valve is with the valve stem vertical above the valve body, for maximum life. However, the assemblies can be mounted with the valve stem vertical or horizontal in relation to the pipe. The actuators should never be mounted underneath the valve, as condensation can build up and result in a failure of the actuators. Do not reverse flow direction.

## G240, 2-Way, Globe Valve, Bronze Trim

### Dimensions (Inches [mm])

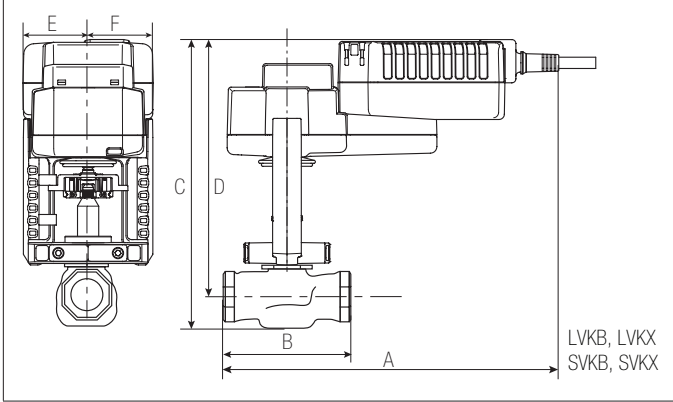

A	B	C	D	E	F
9.5" [241]	5.39" [137]	10.3" [262]	8.5" [216]	1.95" [49]	

### Dimensions (Inches [mm])

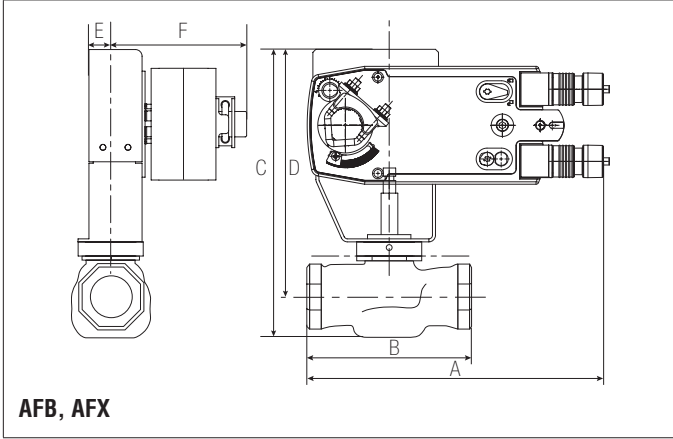

A	B	C	D	E	F
10.5" [267]	5.39" [137]	10.24" [260]	8.7" [221]	1.5" [38]	5" [127]

# AFBUP-X1

On/Off, Spring Return, 24 to 240 VAC









Technical Data	
Power Supply	24...240 VAC +10% / -20%, 50/60 Hz, 24...125 VDC ±10%
Power Consumption Running	7 W
Power Consumption Holding	3.5 W
Transformer Sizing	7 VA @ 24 VAC (class 2 power source), 8.5 VA @ 120 VAC, 18 VA @ 240 VAC
Electrical Connection	3 ft [1 m], 18 GA appliance cable with 1/2" conduit connector
Overload Protection	electronic throughout 0° to 95° rotation
Operating Range	on/off
Angle of Rotation	95° (adjustable with mechanical end stop, 35° to 95°)
Direction of Rotation (Motor)	reversible with built-in switch
Direction of Rotation (Fail-Safe)	reversible with CW/CCW mounting
Position Indication	visual indicator, 0° to 95° (0° is full spring return position)
Manual Override	5 mm hex crank (3/16" Allen), supplied
Running Time (Motor)	<75 sec
Running Time (Fail-Safe)	<20 sec
Humidity	max. 95% RH non-condensing
Ambient Temperature Range	-22°F to 122°F [-30°C to 50°C]
Storage Temperature Range	-40°F to 176°F [-40°C to 80°C]
Housing	NEMA 2, IP54, UL enclosure type 2
Housing Material	zinc coated metal and plastic casing
Agency Listings†	cULus acc. to UL60730-1A/-2-14, CAN/CSA E60730-1:02, CE acc. to 2004/108/EC and 2006/95/EC
Sound power level	<50 dB (A)
Noise Level (Fail-Safe)	<62 dB (A)
Servicing	maintenance free
Quality Standard	ISO 9001
Weight	4.6 lb [2.1 kg]

†Rated Impulse Voltage 4kV, Type of action 1.AA, Control Pollution Degree 3.

Date created, 04/08/2016 - Subject to change. © Belimo Aircontrols (USA), Inc.

**Wiring Diagrams**

-  Universal Power Supply (UP) models can be supplied with 24 VAC up to 240 VAC, or 24 VDC up to 125 VDC.
-  Actuators with appliance cables are numbered.
-  Apply only AC line voltage or only UL-Class 2 voltage to the terminals of auxiliary switches. Mixed or combined operation of line voltage/safety extra low voltage is not allowed.
-  Meets cULus requirements without the need of an electrical ground connection.
-  Provide overload protection and disconnect as required.
-  Actuators may be powered in parallel. Power consumption must be observed.
-  Parallel wiring required for piggy-back applications.

