

G250S, 2-Way, Globe Valve, Stainless Steel Trim

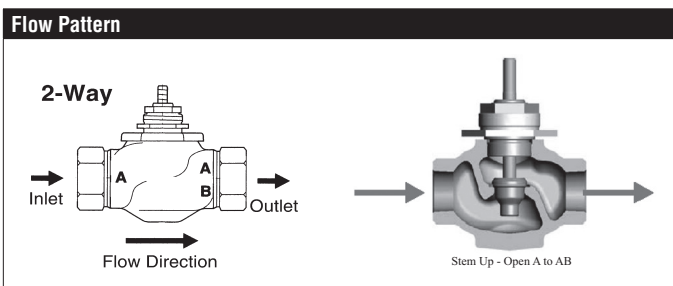

Technical data	
Service	chilled or hot water, up to 60% glycol, steam
Flow Characteristic	linear
Controllable Flow Range	stem up - open A to AB
Size [mm]	2" [50]
End Fitting	NPT female ends
Body	bronze
Stem	316 stainless steel
Stem Packing	spring loaded Teflon V-ring
Seat	316 stainless steel
Plug	316 stainless steel
Disc	Teflon
Body Pressure Rating [psi]	ANSI 250
ANSI Class	ANSI 250 (up to 400 psi below 150°F)
Max Inlet Pressure (Steam)	100 psi (690 kPa)
Media Temperature Range (Water)	20°F to 280°F [-7°C to 138°C]
Media Temperature Range (Steam)	32°F to 338°F [0°C to 170°C]
Maximum differential pressure (steam)	35 psi
Max Differential Pressure (Water)	35 psi (241 kPa)
Leakage	ANSI Class IV
Rangeability	75:1
Cv	40
Weight	8.4 lb [3.8 kg]
Servicing	Repack/Rebuild kits available



Application

This valve is typically used in Air handling units on heating or cooling coils, and fan coil unit heating or cooling coils. Some other common applications include Unit Ventilators, VAV box re-heat coils and bypass loops. This valve is suitable for use in hydronic system with variable flow. Bronze and stainless steel trim valves can be used for steam applications, depending on actuator and close-off combinations.

Suitable Actuators

	Non-Spring	Spring	Electronic Fail-Safe
G250S	SVB(X)	AFB(X)	SVKB(X)

Dimensions (Inches [mm])

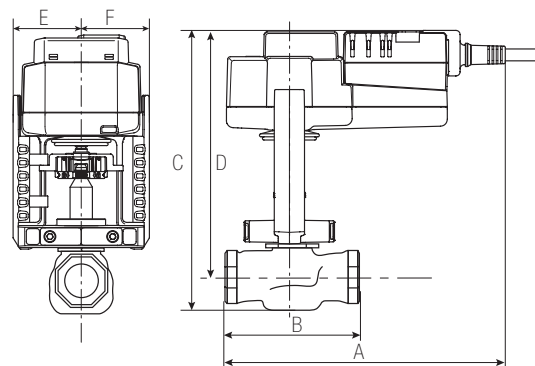

LVB, LVX SVB, SVX

A	B	C	D	E	F
9.3" [236]	6.14" [156]	10.35" [263]	8.78" [223]	1.95" [49]	

Piping

The valves should be mounted in a weather-protected area in a location that is within the ambient limits of the actuator. Allow sufficient room for valve with actuator and for service. The G2(S) and G3(D) preferred mounting position of the valve is with the valve stem vertical above the valve body, for maximum life. However, the assemblies can be mounted with the valve stem vertical or horizontal in relation to the pipe. The actuators should never be mounted underneath the valve, as condensation can build up and result in a failure of the actuators. Do not reverse flow direction.

G250S, 2-Way, Globe Valve, Stainless Steel Trim

Dimensions (Inches [mm])

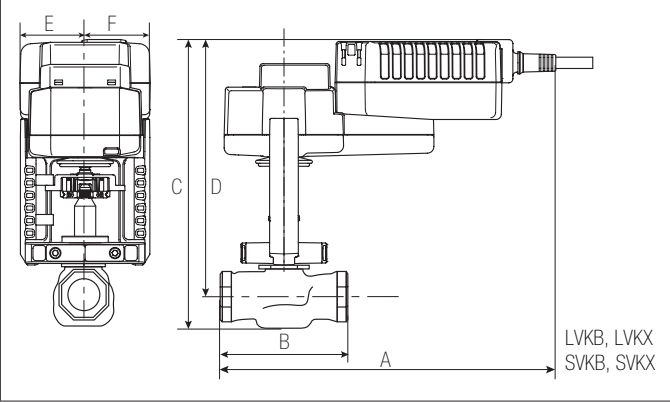

A	B	C	D	E	F
11.50" [292.1]	6.14" [156]	10.3" [262]	8.78" [223]	1.95" [49]	

Dimensions (Inches [mm])

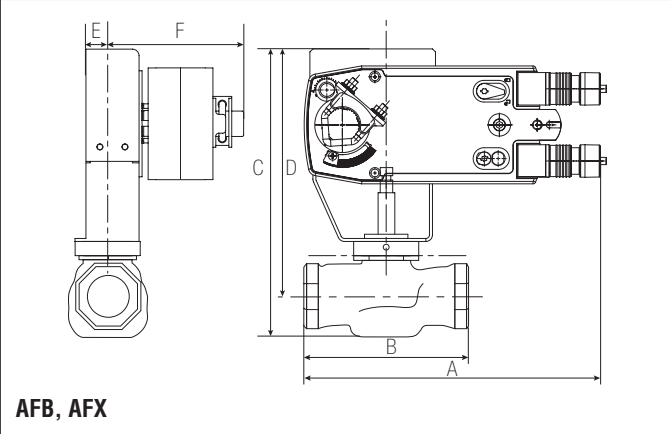

A	B	C	D	E	F
11" [279]	6.14" [156]	10.75" [273]	9.24" [235]	1.5" [38]	5" [127]

AFB24-SR-X1

Modulating, Spring Return, 24 VAC/DC, for 2 to 10 VDC or 4 to 20 mA Control Signal

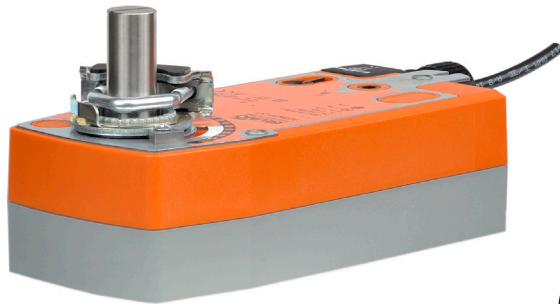

Technical Data	
Power Supply	24 VAC±20%, 50/60Hz, 24 VDC+20%/-10%
Power Consumption Running	5.5 W
Power Consumption Holding	3 W
Transformer Sizing	8.5 VA (class 2 power source)
Electrical Connection	3 ft [1 m], 18 GA appliance cable with 1/2" conduit connector
Overload Protection	electronic throughout 0° to 95° rotation
Operating Range	on/off
Position Feedback	2 to 10 VDC, 0.5 mA max
Angle of Rotation	95° (adjustable with mechanical end stop, 35° to 95°)
Direction of Rotation (Motor)	reversible with built-in switch
Direction of Rotation (Fail-Safe)	reversible with CW/CCW mounting
Position Indication	visual indicator, 0° to 95° (0° is full spring return position)
Manual Override	5 mm hex crank (3/16" Allen), supplied
Running Time (Motor)	95 sec
Running Time (Fail-Safe)	<20 sec
Humidity	max. 95% RH non-condensing
Ambient Temperature Range	-22°F to 122°F [-30°C to 50°C]
Storage Temperature Range	-40°F to 176°F [-40°C to 80°C]
Housing	NEMA 2, IP54, UL enclosure type 2
Housing Material	zinc coated metal and plastic casing
Agency Listings†	cULus acc. to UL60730-1A/-2-14, CAN/CSA E60730-1:02, CE acc. to 2004/108/EC
Sound power level	<40 dB (A)
Noise Level (Fail-Safe)	<62 dB (A)
Servicing	maintenance free
Quality Standard	ISO 9001
Weight	4.6 lb [2.1 kg]

†Rated Impulse Voltage 800V, Type of action 1.AA, Control Pollution Degree 3

Date created, 04/08/2016 - Subject to change. © Belimo Aircontrols (USA), Inc.

Wiring Diagrams

- ◆ Meets cULus requirements without the need of an electrical ground connection.
- Ⓐ Actuators with appliance cables are numbered.
- 1 Provide overload protection and disconnect as required.
- 3 Actuators may also be powered by 24 VDC.
- 5 Only connect common to negative (-) leg of control circuits.
- 7 A 500 Ω resistor (ZG-R01) converts the 4 to 20 mA control signal to 2 to 10 VDC.
- 11 Actuators may be connected in parallel if not mechanically linked. Power consumption and input impedance must be observed.

