

P6250S-127-250, 2-1/2", ANSI 250 Electronic Pressure Independent Valve

Cast Iron Body, Stainless Steel Trim



Technical Data	
Service	chilled or hot water, up to 60% glycol max (open loop/steam not allowed)
Flow Characteristic	equal percentage or linear
Controllable Flow Range	stem up - open A to AB
Size [mm]	2.5" [65]
End Fitting	250 lb flanged
Body	cast iron - ASTM A126 Class B
Stem	316 stainless steel
Stem Packing	NLP EPDM (no lip packing)
Seat	316 stainless steel
Plug	stainless steel
Sensor Housing	ductile iron - GGG50
Body Pressure Rating [psi]	ANSI 250
GPM Range	38-127
Number of Bolt Holes	8
Max Inlet Pressure (Water)	300 psi (2068 kPa) @ 250°F [121°C]
Media Temperature Range (Water)	14°F to 250°F [-10°C to 120°C]
Conductivity of Fluid	Min. 20uS/cm
Differential Pressure Range	7.5 to 50 psid or 1 to 50 psid with flow reductions
Max Differential Pressure (Water)	50 psi (345 kPa)
Close-Off Pressure	310 psi
Leakage	ANSI Class IV
Inlet Length to Meet Specified Measurement Accuracy	5X nominal pipe size (NPS)
Flow Measurement Tolerance	±2%*
Flow Control Tolerance	±5%
Flow Measurement Repeatability	±0.5%
Sensor Technology	electromagnetic
Weight	119 lb [54 kg]
Manual Override	5 mm hex crank (3/16" Allen), supplied
Servicing	Repack/Rebuild kits available
Quality Standard	ISO 9001

*All flow tolerances are at 68°F (20°C) & water.

Application

Water-side control of heating and cooling systems for AHUs and water coils. Equal Percentage/ Linear: heating and cooling applications.

Operation

The Electronic Pressure Independent Control Valve is a two-way valve that maintains constant flow regardless of pressure variations in the system.

Product Features

Provides constant flow regardless of pressure variations in the system. Maximizes chiller P, preventing energizing additional chillers due to low T. Simplified valve sizing and selection, no Cv calculations required.

Suitable Actuators

	Non-Spring	Electronic Fail-Safe
P6250S-127-250	EVX	AVKX

Dimensions (Inches [mm])

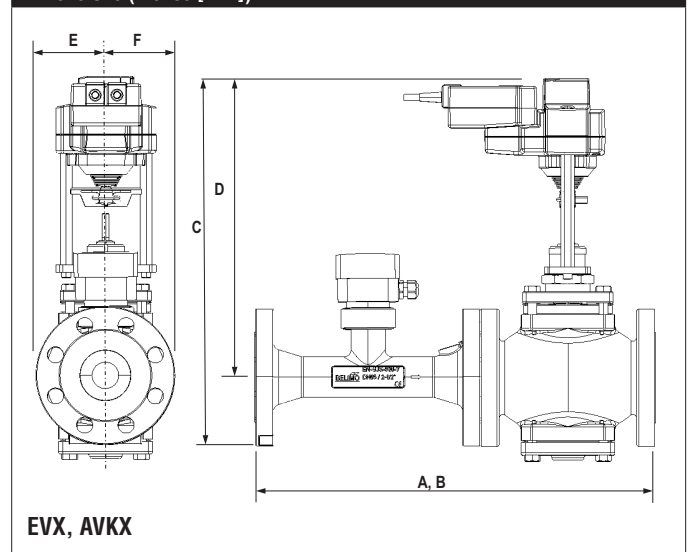

A	B	C	D	E	F
22.2" [564]		20.4" [516]	18.25" [464]	4.5" [114]	4.5" [114]

Piping

The valves should be mounted in a weather-protected area in a location that is within the ambient limits of the actuator. Allow sufficient room for valve with actuator and for service. The preferred mounting position of the valve is with the valve stem vertical above the valve body, for maximum life. However, the assemblies can be mounted with valve stem vertical above the valve or up to 45 degrees in relation to the horizontal pipe. The actuators should never be mounted underneath the valve, as condensation can build up and result in a failure of the actuators. Do not reverse flow direction.

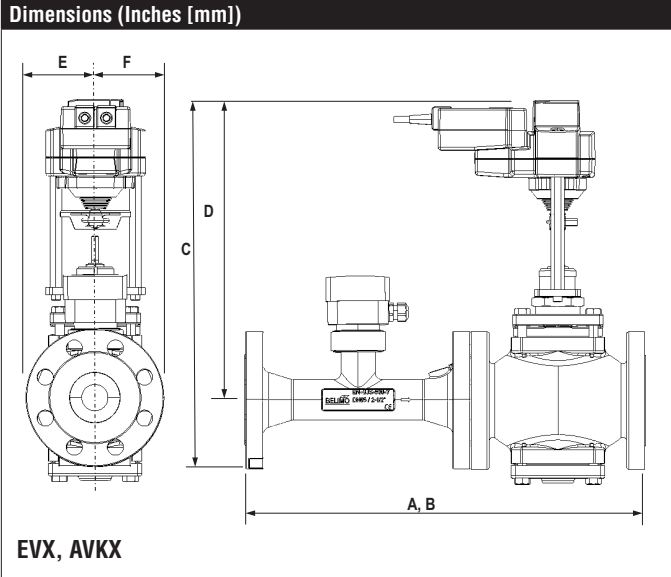

A	B	C	D	E	F
22.2" [564]		20.4" [516]	18.25" [464]	4.5" [114]	4.5" [114]

AVKX24-PI-L

Modulating, Electronic Fail-Safe, 24 V, for 2 to 10 VDC or 4 to 20 mA Control Signal



Technical Data

Power Supply	24 VAC \pm 20%, 50/60 Hz, 24 VDC \pm 10%
Power Consumption Running	5 W
Power Consumption Holding	2 W
Transformer Sizing	9.5 VA (class 2 power source)
Electrical Connection	3ft [1m], 18 GA plenum cable with 1/2" conduit connector
Overload Protection	electronic throughout full stroke
Electrical Protection	actuators are double insulated
Operating Range Y	2 to 10 VDC (default) VDC variable
Input Impedance	100 k Ω (0.1 mA), 500 Ω
Feedback Output U	2 to 10 VDC (default) VDC variable
Stroke	0.75" [19 mm]
Direction of Rotation (Motor)	reversible with switch
Direction of Rotation (Fail-Safe)	reversible with switch
Position Indication	stroke indicator on bracket
Manual Override	5 mm hex crank (3/16" Allen), supplied
Running Time (Motor)	90 sec, constant independent of load
Running Time (Fail-Safe)	35 sec
Bridge Time	2 sec delay before fail-safe activates
Pre-charging Time	5 to 20 seconds
Humidity	5 to 95% RH non-condensing
Ambient Temperature Range	-22°F to 122°F [-30°C to 50°C]
Storage Temperature Range	-40°F to 176°F [-40°C to 80°C]
Housing	NEMA 2, IP54, UL enclosure type 2
Housing Material	Aluminum die cast and plastic casing
Agency Listings†	cULus acc. to UL60730-1A/-2-14, CAN/CSA E60730-1:02, CE acc. to 2004/108/EC and 2006/95/EC
Noise Level (Motor)	<60 dB (A)
Noise Level (Fail-Safe)	<60 dB (A)
Servicing	maintenance free
Quality Standard	ISO 9001
Weight	6.4 lb [2.9 kg]

† Use flexible metal conduit. Push the listed conduit fitting device over the actuator's cable to butt against the enclosure. Screw in conduit connector. Jacket the actuators input wiring with listed flexible conduit. Properly terminate the conduit in a suitable junction box. Rated impulse Voltage 800V. Type of action 1. Control pollution degree 3.

In cases where the valve body is electrically isolated from the water pipe, an earth ground should be installed in order for the sensor to work properly. Earth ground can be connected directly on the sensor body. A connection point is provided on the flange of the sensor body.

Wiring Diagrams
INSTALLATION NOTES

- Provide overload protection and disconnect as required.
- Actuators may be connected in parallel. Power consumption and input impedance must be observed.
- Actuators may also be powered by 24 VDC.
- A 500 Ω resistor (ZG-R01) converts the 4 to 20 mA control signal to 2 to 10 VDC.
- Actuators with plenum cable do not have numbers; use color codes instead.
- Meets cULus requirements without the need of an electrical ground connection.

WARNING! LIVE ELECTRICAL COMPONENTS!
 During installation, testing, servicing and troubleshooting of this product, it may be necessary to work with live electrical components. Have a qualified licensed electrician or other individual who has been properly trained in handling live electrical components perform these tasks. Failure to follow all electrical safety precautions when exposed to live electrical components could result in death or serious injury.

