

SY9-220

On/Off Floating Point, Non-Spring Return, 220 V



Application

SY Series actuators are fractional horsepower devices, and utilize full-wave power supplies. Observe wire sizing and transformer sizing requirements. Proportional models CANNOT be connected to Belimo direct coupled (AF, AM, GM...etc) actuator power supplies or any type of half-wave device. You MUST use a separate, dedicated transformer or power supply to power the SY actuator. Please do not connect other automation equipment to the dedicated SY supply source. You MUST use four wires (plus a ground) to control a proportional control SY actuator (See SY Wiring Section).

Technical Data	
Power Supply	230 VAC \pm 10%, 50/60 Hz
Power Consumption Running	509 W
Transformer Sizing	552 VA (class 2 power source)
Electrical Connection	terminal block
Overload Protection	thermally protected 135°C cut-out
Operating Range Y	on/off, floating point
Angle of Rotation	90°
Torque	17800 in-lbs [2000 Nm] minimum
Duty cycle	30%
Direction of Rotation (Motor)	reversible with built-in switch
Position Indication	top mounted domed indicator
Manual Override	hand wheel
Running Time (Motor)	63 sec
Internal Humidity Control	resistive heating element
Ambient Humidity	5 to 100% RH (UL Type 4)
Ambient Temperature Range	-22°F to 150°F [-30°C to 65°C]
Storage Temperature Range	-40°F to 176°F [-40°C to 80°C]
Housing	NEMA 4X, IP66/67, UL Enclosure Type 4
Housing Material	die cast aluminum alloy
Gear Train	high alloy steel gear sets, self locking
Agency Listings†	ISO, CE, cCSAus
Noise Level (Motor)	<45 dB (A)
Servicing	maintenance free
Quality Standard	ISO 9001
Weight	134.5 lb [61 kg]
Auxiliary Switch	2 x SPDT 3A resistive (0.5A inductive) @ 250 VAC, one set at +10° and one set at 85°

Wiring Diagrams
INSTALLATION NOTES

- Do not change sensitivity or dip switch setting with power applied.
- Power supply Common/Neutral and Control Signal “-” wiring to a common is prohibited. Terminals 4 and 6 need to be wired separately.
- Isolation relays must be used in parallel connection of multiple actuators using a common control signal inputs. The relays should be DPDT.
- Isolation relays are required in parallel applications. The reason parallel applications need isolation relays is that the motor uses two sets of windings, one for each direction. When one is energized to turn the actuator in a specific direction a voltage is generated in the other due to the magnetic field created from the first. It's called back EMF. This is not an issue with one actuator because the voltage generated in the second winding isn't connected to anything so there is no flow. On parallel applications without isolation, this EMF voltage energizes the winding it is connected to on the other actuators in the system, the actuators are trying to turn in both directions at once. The EMF voltage is always less than the supply voltage due to the resistance of the windings, so while the actuator still turns in the commanded direction, the drag from the other reduces the torque output and causes overheating.

WARNING! LIVE ELECTRICAL COMPONENTS!
 During installation, testing, servicing and troubleshooting of this product, it may be necessary to work with live electrical components. Have a qualified licensed electrician or other individual who has been properly trained in handling live electrical components perform these tasks. Failure to follow all electrical safety precautions when exposed to live electrical components could result in death or serious injury.

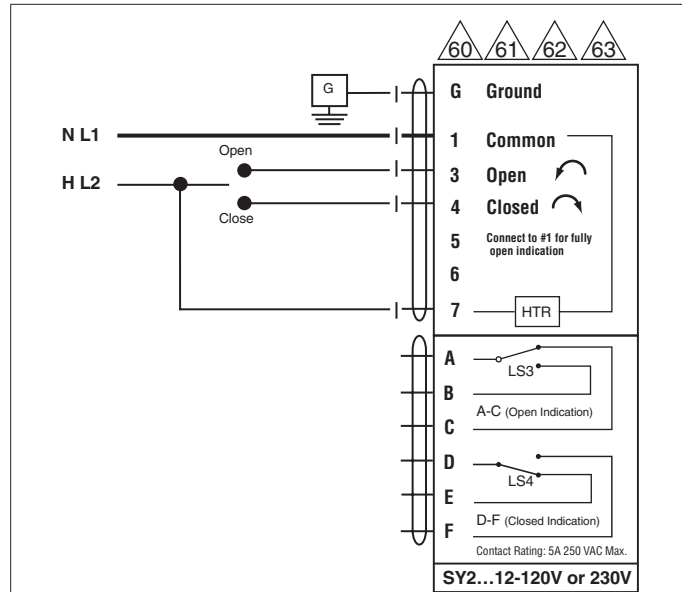
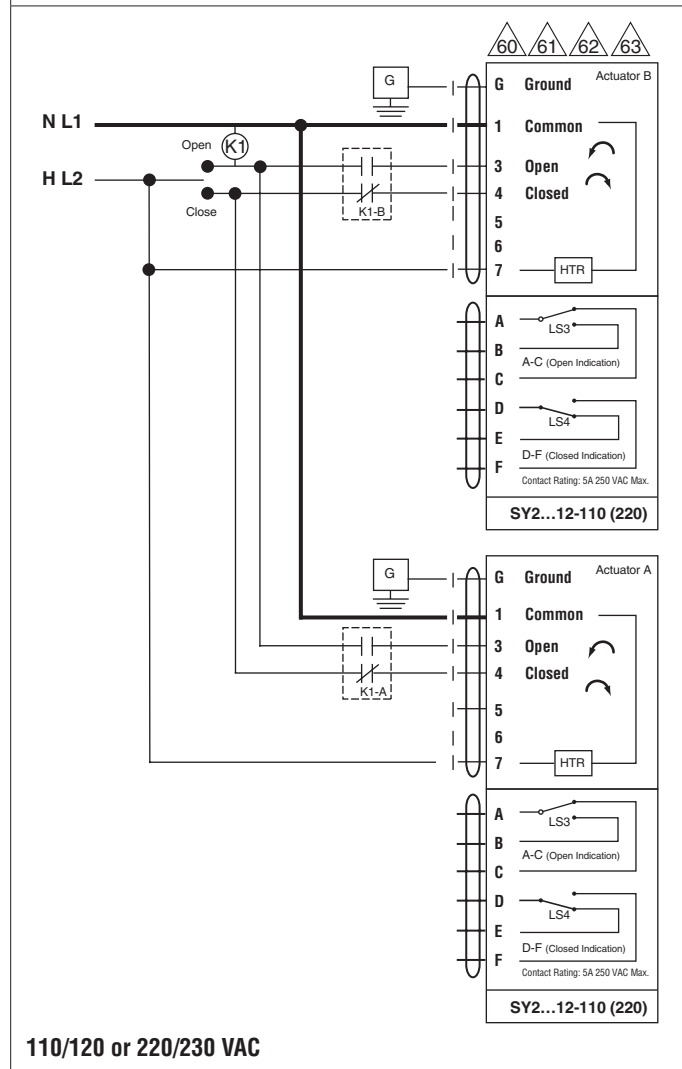
110/120V or 220/230V AC/DC

110/120 or 220/230 VAC