

**Cable temperature sensor**

Active sensor (0...10 V) for measuring the temperature in pipe and air applications. Incorporates a stainless steel probe and plenum-rated cable. NEMA 4X / IP65 rated enclosure.



5-year warranty

**Type Overview**

Type	Output signal active temperature	Cable length	Probe length	Probe diameter
22CT-52H	0...5 V, 0...10 V	2 m	2" [50 mm]	0.24" [6 mm]

**Technical data**

<b>Electrical Data</b>	Nominal voltage	AC/DC 24 V		
	Nominal voltage range	AC 21.6...26.4 V / DC 13.5...26.4 V		
	Power consumption AC	0.8 VA		
	Power consumption DC	0.45 W		
	Electrical connection	Pluggable spring loaded terminal block max. 2.5 mm <sup>2</sup>		
	Cable entry	Cable gland with strain relief Ø6...8 mm (1/2" NPT conduit adapter included)		
	Cable specification	1 pair shielded plenum cable, 22AWG tinned copper, green jacket, -40...150°C [-40...300°F], 300 V		
<b>Functional Data</b>	Sensor Technology	based on Pt1000 1/3 DIN		
	Application	air water		
	Multirange	8 measuring ranges selectable		
	Voltage output	1x 0...5 V, 0...10 V, min. load 5 kΩ		
	Output signal active note	output 0...5/10 V with jumper adjustable		
<b>Measuring Data</b>	Measured values	Temperature		
	Measuring range temperature	Active sensor: range selectable Attention: max. measuring temperature is restricted by max. fluid temperature (see Safety data)		
		Setting	Range [°C]	Range [°F] Factory setting
		S0	-50...50	-30...130
		S1	-10...120	0...250
		S2	0...50	40...140
		S3	0...250	30...480
		S4	-15...35	0...100
		S5	0...100	40...240
		S6	-20...80	40...90
	S7	0...160	0...150	✓
	Accuracy temperature active	±0.9°F @ 70°F [±0.5°C @ 21°C]		
	Long-term stability	±0.07°F p.a. @ 70°F [±0.04°C p.a. @ 21°C] [±39.2°F p.a. @ 69.8°F]		

<b>Measuring Data</b>	Time constant $\tau$ (63%) in air duct	Typical 155 s @ 0 m/s Typical 35 s @ 3 m/s
	Time constant $\tau$ (63%) in water pipe	With thermowell A-22P-A.. and thermal contact fluid Typical 7 s with thermowell brass Typical 9 s with thermowell stainless steel
<b>Materials</b>	Cable gland	PA6, black
	Mounting plate	PC, grey RAL 7001
	Housing	Cover: PC, orange Bottom: PC, orange Seal: NBR70, black UV resistant
<b>Safety Data</b>	Ambient humidity	Max. 95% RH, non-condensing
	Ambient temperature	-30...120°F [-35...50°C]
	Fluid temperature	-40...300°F [-40...150°C]
	Housing surface temperature	max. 160°F [70°C]
	Protection class IEC/EN	III, Protective Extra-Low Voltage (PELV)
	Power source UL	Class 2 Supply
	EU Conformity	CE Marking
	Certification IEC/EN	IEC/EN 60730-1
	Certification UL	cULus acc. to UL60730-1A/-2-9, CAN/CSA E60730-1/-2-9
	Degree of protection IEC/EN	IP65
	Degree of protection NEMA/UL	NEMA 4X
	Enclosure	UL Enclosure Type 4X
	Quality Standard	ISO 9001
	Mode of operation	Type 1
	Pollution degree	3
Rated impulse voltage supply	0.8 kV	
Construction	Independently mounted control	

### Safety Notes



This device has been designed for use in stationary heating, ventilation and air-conditioning systems and must not be used outside the specified field of application. Unauthorized modifications are prohibited. The product must not be used in relation with any equipment that in case of a failure may threaten humans, animals or assets.

Ensure all power is disconnected before installing. Do not connect to live/operating equipment.

Only authorized specialists may carry out installation. All applicable legal or institutional installation regulations must be complied during installation.

The device contains electrical and electronic components and must not be disposed of as household refuse. All locally valid regulations and requirements must be observed.

### Remarks

- General Remarks Concerning Sensors** When using lengthy connection wires (depending on the cross section used) the measuring result might be falsified due to a voltage drop at the common GND-wire (caused by the voltage current and the line resistance). In this case, 2 GND-wires must be wired to the sensor - one for supply voltage and one for the measuring current.
- Sensing devices with a transducer should always be operated in the middle of the measuring range to avoid deviations at the measuring end points. The ambient temperature of transducer electronics should be kept constant. The transducers must be operated at a constant supply voltage ( $\pm 0.2$  V). When switching the supply voltage on/off, onsite power surges must be avoided.

**Build-up of self-heating by electrical dissipative power**

Temperature sensors with electronic components always have a dissipative power which affects the temperature measurement of the ambient air. The dissipation in active temperature sensors shows a linear increase with rising operating voltage. The dissipative power should be taken into account when measuring temperature. In case of a fixed operating voltage ( $\pm 0.2$  V) this is normally done by adding or reducing a constant offset value. As Belimo transducers work with a variable operating voltage, only one operating voltage can be taken into consideration, for reasons of production engineering. Transducers 0...10 V / 4...20 mA have a standard setting at an operating voltage of DC 24 V. That means, that at this voltage, the expected measuring error of the output signal will be the least. For other operating voltages, the offset error will be increased by a changing power loss of the sensor electronics.

If a readjustment directly at the active sensor should be necessary during later operation, this can be done with the following adjustment methods.

- For sensors with NFC or dongle by the corresponding Belimo app
- For sensors with a trimming potentiometer on the sensor board
- For bus sensors via bus interface with a corresponding software variable

**Scope of delivery**

Scope of delivery	Description	Type
	Mounting plate S housing	A-22D-A09
	Dowel	
	Screws	
	1/2" NPT conduit adapter	

**Accessories**

Optional accessories air	Description	Type
	Mounting flange for sensor probe 6 mm, up to max. 120°C [248°F], Plastic	A-22D-A03
	Mounting flange for sensor probe 6 mm, up to max. 260°C, Brass	A-22D-A05
Recommended accessories water	Description	Type
	Thermowell (fabricated) Stainless steel, 2" [50 mm], 1/2" NPT, wrench size 3/4"	A-22P-A05
	Thermowell (fabricated) Brass, 2" [50 mm], 1/2" NPT, wrench size 3/4"	A-22P-A17
	Thermowell (machined) Stainless steel, 2" [50 mm], 1/2" NPT, wrench size 3/4"	A-22P-A36
	Thermowell (fabricated) Stainless steel, 4" [100 mm], 1/2" NPT, wrench size 3/4"	A-22P-A07
	Thermowell (fabricated) Brass, 4" [100 mm], 1/2" NPT, wrench size 3/4"	A-22P-A19
	Thermowell (machined) Stainless steel, 4" [100 mm], 1/2" NPT, wrench size 3/4"	A-22P-A37
	Thermowell (fabricated) Stainless steel, 6" [150 mm], 1/2" NPT, wrench size 3/4"	A-22P-A09
	Thermowell (fabricated) Brass, 6" [150 mm], 1/2" NPT, wrench size 3/4"	A-22P-A21
	Thermowell (machined) Stainless steel, 6" [150 mm], 1/2" NPT, wrench size 3/4"	A-22P-A38
	Thermowell (fabricated) Stainless steel, 8" [200 mm], 1/2" NPT, wrench size 3/4"	A-22P-A11
	Thermowell (fabricated) Brass, 8" [200 mm], 1/2" NPT, wrench size 3/4"	A-22P-A23
	Thermowell (machined) Stainless steel, 8" [200 mm], 1/2" NPT, wrench size 3/4"	A-22P-A39
	Thermowell (fabricated) Stainless steel, 12" [300 mm], 1/2" NPT, wrench size 3/4"	A-22P-A13
	Thermowell (fabricated) Brass, 12" [300 mm], 1/2" NPT, wrench size 3/4"	A-22P-A25
	Thermowell (fabricated) Stainless steel, 18" [450 mm], 1/2" NPT, wrench size 3/4"	A-22P-A15
	Thermowell (fabricated) Brass, 18" [450 mm], 1/2" NPT, wrench size 3/4"	A-22P-A27
	Syringe with thermal paste	A-22P-A44
	Compression fitting, Stainless steel, G 1/4" (external thread) for 0.24" [6 mm], with cutting ring	A-22P-A45
	Cold barrier, Plastic, L 50 mm, for thermowell A-22P-A..	A-22P-A51

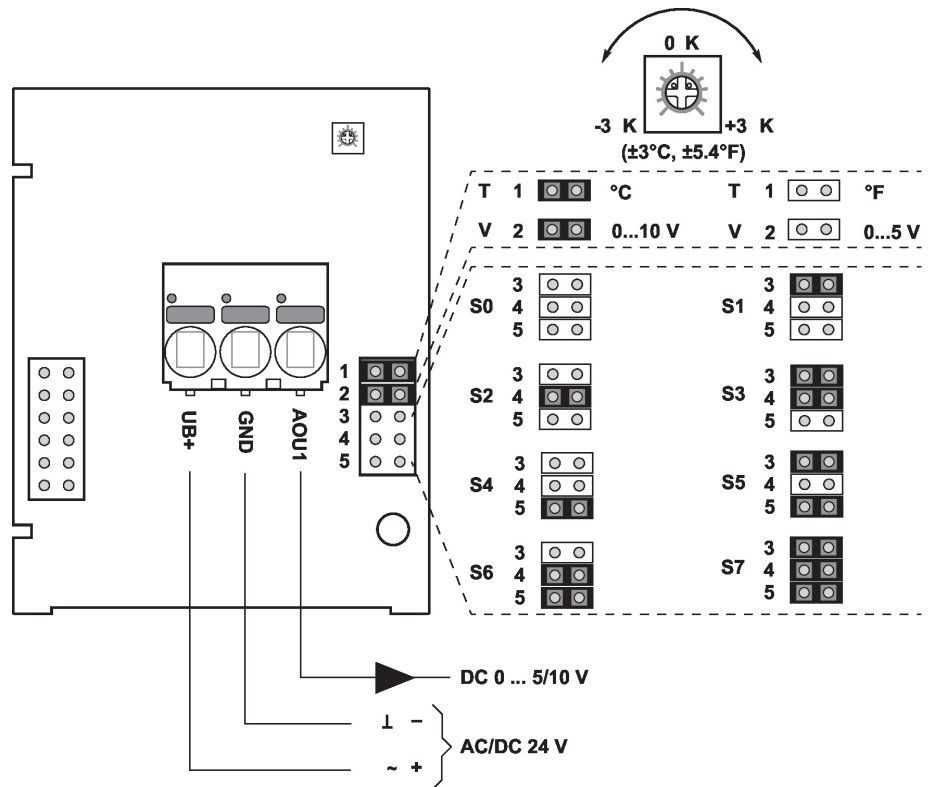

The adjustment of the measuring ranges is made by changing the bonding jumpers. The output value in the new measuring range is available after 2 seconds.

Setting	Range [°C]	Range [°F]	Factory setting
S0	-50...50	-30...130	
S1	-10...120	0...250	
S2	0...50	40...140	
S3	0...250	30...480	
S4	-15...35	0...100	
S5	0...100	40...240	
S6	-20...80	40...90	
S7	0...160	0...150	✓

Dimensions

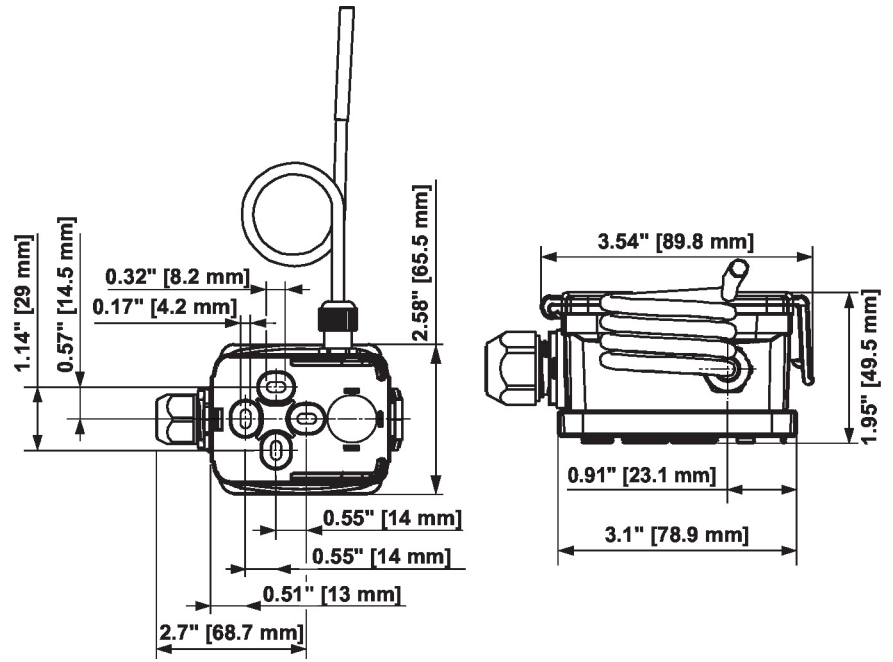

Type	Probe length	Weight
22CT-52H	2" [50 mm]	0.44 lb [0.20 kg]