



5-year warranty



Type overview

Type	DN
B339	40

Technical data

<b>Functional data</b>	Valve size	1.5" [40]
	Fluid	chilled or hot water, up to 60% glycol
	Fluid Temp Range (water)	0...250°F [-18...120°C]
	Body Pressure Rating	400 psi
	Close-off pressure Δps	200 psi
	Flow characteristic	A-port equal percentage, B-port modified for constant common port flow
	Servicing	maintenance-free
	Flow Pattern	3-way Mixing/Diverting
	Leakage rate	0% for A – AB, <2.0% for B – AB
	Controllable flow range	75°
	Cv	29
	Cv Flow Rating	A-port: as stated in chart B-port: 70% of A – AB Cv
	<b>Materials</b>	Valve body
Stem		stainless steel
Stem seal		EPDM (lubricated)
Seat		PTFE
Characterized disc		TEFZEL®
Pipe connection		NPT female ends
O-ring		EPDM (lubricated)
<b>Suitable actuators</b>	Non-Spring	ARB(X)
	Spring	AFRB(X)

Safety notes



- WARNING: This product can expose you to lead which is known to the State of California to cause cancer and reproductive harm. For more information go to [www.p65warnings.ca.gov](http://www.p65warnings.ca.gov)

**Product features**

**Application** This valve is typically used in air handling units on heating or cooling coils, and fan coil unit heating or cooling coils. Some other common applications include Unit Ventilators, VAV box re-heat coils and bypass loops. This valve is suitable for use in a hydronic system with variable or constant flow.

**Flow/Mounting details**



**Product features**

**Mode of operation** Local Control SY2-12, 110vac Mod

**Dimensions**

<b>Type</b>	<b>DN</b>
B339	40

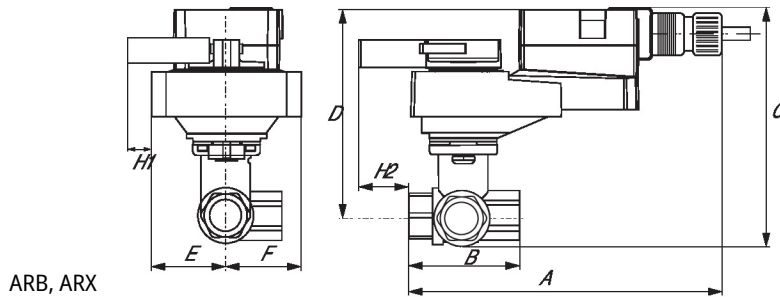

ARB, ARX

A	B	C	D	E	F	H1	H2
10.0" [254]	4.4" [112]	7.2" [184]	5.7" [146]	1.7" [44]	2.3" [58]	0.8" [20]	0.6" [15]

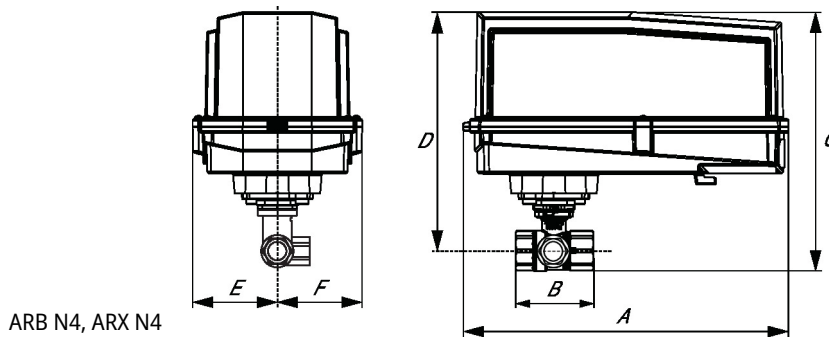

ARB N4, ARX N4

A	B	C	D	E	F
11.4" [289]	4.4" [112]	9.3" [236]	7.8" [198]	3.1" [80]	3.1" [80]

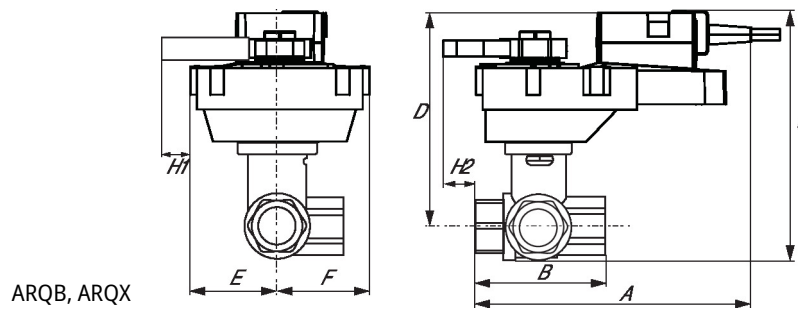

ARQB, ARQX

A	B	C	D	E	F	H1	H2
9.9" [251]	4.4" [112]	7.8" [199]	6.3" [161]	2.3" [58]	2.3" [58]	0.8" [20]	0.8" [20]

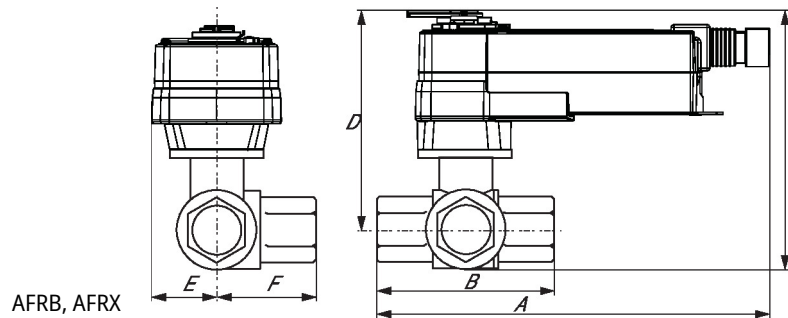

AFRB, AFRX

A	B	C	D	E	F
10.8" [275]	4.4" [112]	7.9" [201]	6.4" [162]	2.3" [58]	2.3" [58]

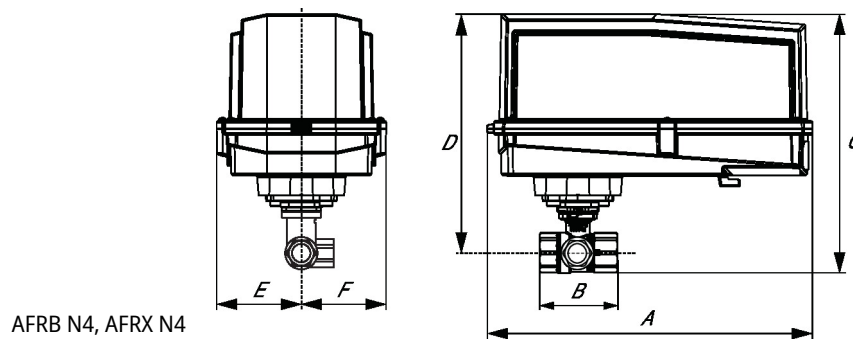

AFRB N4, AFRX N4

A	B	C	D	E	F
13.0" [330]	4.4" [112]	11.2" [284]	9.7" [246]	3.7" [95]	3.7" [95]



5-year warranty



Technical data

<b>Electrical data</b>	Nominal voltage	AC/DC 24 V	
	Nominal voltage frequency	50/60 Hz	
	Power consumption in operation	7.5 W	
	Power consumption in rest position	3 W	
	Transformer sizing	10 VA (class 2 power source)	
	Electrical Connection	18 GA appliance cable, 3 ft [1 m], with 1/2" conduit connector	
	Overload Protection	electronic throughout 0...95° rotation	
<b>Functional data</b>	Operating range Y	2...10 V	
	Operating range Y note	4...20 mA w/ ZG-R01 (500 Ω, 1/4 W resistor)	
	Input Impedance	100 kΩ for 2...10 V (0.1 mA), 500 Ω for 4...20 mA, 1500 Ω for PWM, On/Off and Floating point	
	Operating range Y variable	Start point	0.5...30 V
		End point	2.5...32 V
	Options positioning signal	variable (VDC, PWM, on/off, floating point)	
	Position feedback U	2...10 V	
	Position feedback U note	Max. 0.5 mA	
	Position feedback U variable	VDC variable	
	Direction of motion motor	selectable with switch	
	Direction of motion fail-safe	reversible with cw/ccw mounting	
	Manual override	5 mm hex crank (3/16" Allen), supplied	
	Angle of rotation	90°	
	Running Time (Motor)	150 s / 90°	
	Running time motor variable	70...220 s	
	Running time fail-safe	<20 s	
	Angle of rotation adaptation	off (default)	
	Override control	MIN (minimum position)	= 0%
		MID (intermediate position)	= 50%
		MAX (maximum position)	= 100%
Noise level, motor	45 dB(A)		
Noise level, fail-safe	62 dB(A)		
Position indication	Mechanical		
<b>Safety data</b>	Degree of protection IEC/EN	IP66	
	Degree of protection NEMA/UL	NEMA 4X	
	Enclosure	UL Enclosure Type 4X	
	Agency Listing	cULus acc. to UL60730-1A/-2-14, CAN/CSA E60730-1:02, CE acc. to 2014/30/EU and 2014/35/EU	
	Quality Standard	ISO 9001	
	Ambient temperature	-22...122°F [-30...50°C]	

<b>Safety data</b>	Ambient temperature note	-40...50°C for actuator with integrated heating
	Storage temperature	-40...176°F [-40...80°C]
	Ambient humidity	Max. 100% RH
	Servicing	maintenance-free
<b>Materials</b>	Housing material	Die cast aluminium and plastic casing

**Footnotes** †Rated Impulse Voltage 800V, Type of Action 1, Control Pollution Degree 2.

## Accessories

<b>Gateways</b>	<b>Description</b>	<b>Type</b>
	Gateway MP to BACnet MS/TP	UK24BAC
	Gateway MP to Modbus RTU	UK24MOD
	Gateway MP to LonWorks	UK24LON
<b>Electrical accessories</b>	<b>Description</b>	<b>Type</b>
	Service Tool, with ZIP-USB function, for programmable and communicative Belimo actuators, VAV controller and HVAC performance devices	ZTH US
<b>Service tools</b>	<b>Description</b>	<b>Type</b>
	Connection cable 10 ft [3 m], A: RJ11 6/4 ZTH EU, B: 3-pin Weidmüller and supply connection	ZK4-GEN
	Service Tool, with ZIP-USB function, for programmable and communicative Belimo actuators, VAV controller and HVAC performance devices	ZTH US

## Electrical installation

### **INSTALLATION NOTES**

-  Actuators with appliance cables are numbered.
-  Provide overload protection and disconnect as required.
-  Actuators may also be powered by DC 24 V.
-  Only connect common to negative (-) leg of control circuits.
-  A 500 Ω resistor (ZG-R01) converts the 4...20 mA control signal to 2...10 V.
-  Control signal may be pulsed from either the Hot (Source) or Common (Sink) 24 V line.
-  For triac sink the Common connection from the actuator must be connected to the Hot connection of the controller. Position feedback cannot be used with a triac sink controller; the actuator internal common reference is not compatible.
-  IN4004 or IN4007 diode. (IN4007 supplied, Belimo part number 40155).
-  Actuators may be controlled in parallel. Current draw and input impedance must be observed.
-  Master-Slave wiring required for piggy-back applications. Feedback from Master to control input(s) of Slave(s).
-  Meets cULus requirements without the need of an electrical ground connection.
-  **Warning! Live electrical components!**  
During installation, testing, servicing and troubleshooting of this product, it may be necessary to work with live electrical components. Have a qualified licensed electrician or other individual who has been properly trained in handling live electrical components perform these tasks. Failure to follow all electrical safety precautions when exposed to live electrical components could result in death or serious injury.

### Wiring diagrams

On/Off

24 VAC Transformer



Floating Point

24 VAC Transformer (AC Only)



VDC/mA Control

24 VAC Transformer



PWM Control

24 VAC Transformer (AC only)

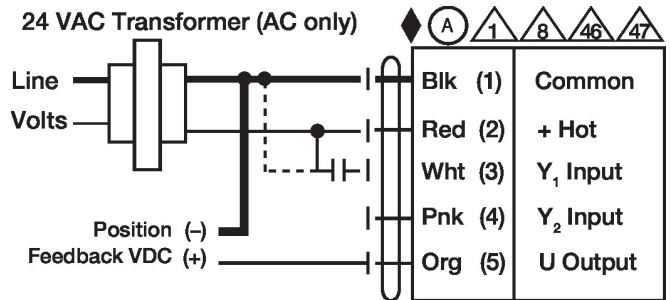

Override Control

24 VAC Transformer (AC Only)



Master - Slave

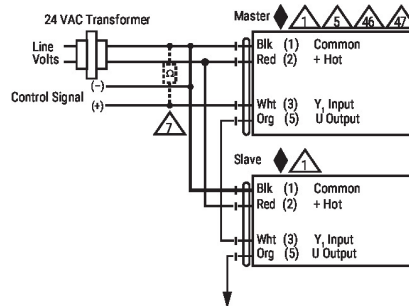

### Dimensions