

F7 Series 3-Way, ANSI Class 300 Butterfly Valve Reinforced Teflon Seat, 316 Stainless Disc



- Bubble tight shut-off to ANSI Class 300 Standards
- Long stem design allows for 2" insulation minimum
- Valve Face-to-face dimensions comply with API 609 & MSS-SP-68
- Designed to be installed between ASME/ANSI 16.5 Flanges
- Completely assembled and tested, ready for installation
- Tees comply with ASME/ANSI 16.5 Class 250/300 Flanges

Application

These valves are designed to meet the needs of HVAC and Commercial applications requiring positive shut-off for liquids at higher pressures and temperatures. Typical applications include chiller isolation, cooling tower isolation, change-over systems, large air handler coil control, bypass and process control applications. The large C_v values provide for an economical control valve solution for larger flow applications.

Dead End Service

Utilizes larger retainer ring set screws to allow the valve to be placed at the end of the line without a down stream flange in either flow direction while still holding full pressure.

Technical Data	
Service	chilled, hot water, 60% glycol, steam to 50 psi
Flow characteristic	modified equal percentage, unidirectional
Controllable flow range	82°
Sizes	2" to 12"
Type of end fitting	ANSI 300 flanges
Materials	
Body	carbon steel full lug
Disc	316 stainless steel
Seat	RPTFE
Shaft	17-4 PH stainless
Gland seal	PTFE
Bushings	glass backed PTFE
Media temperature range	-20°F to 400°F [-30°C to 204°C]
Body pressure rating	ANSI Class 300
Close-off pressure	740 psi
Rangeability	100:1 (for 30 deg to 70 deg range)
Maximum velocity	32 FPS
Leakage	bubble tight

C _v 90°	C _v 60°	3-way Valves		Suitable Actuators			
		Inches	ANSI 300 3-way	Non Fail-Safe		Electronic Fail-Safe	
				300		300	
102	56	2	F750-300SHP	GM Series	PR Series	PKR	GK Series
146	80	2½	F765-300SHP				
228	125	3	F780-300SHP				
451	248	4	F7100-300SHP	SY Series (2 Year Warranty)			
714	392	5	F7125-300SHP				
1103	607	6	F7150-300SHP				
2064	1135	8	F7200-300SHP				
3517	1934	10	F7250-300SHP				
4837	2660	12	F7300-300SHP				

Valve	Size	C _v	MOD									ON/OFF
			10°	20°	30°	40°	50°	60°	70°	80°	90°	
F750-300SHP	2"	102	1.50	6.10	14	26	39	56	77	99	102	
F765-300SHP	2½"	146	2.20	8.80	20	37	55	80	110	142	146	
F780-300SHP	3"	228	3.40	14	32	57	87	125	171	221	228	
F7100-300SHP	4"	451	6.80	27	63	114	171	248	338	437	451	
F7125-300SHP	5"	714	11	43	100	180	271	393	536	693	714	
F7150-300SHP	6"	1103	17	66	154	278	419	607	827	1070	1103	
F7200-300SHP	8"	2064	31	124	289	520	784	1135	1548	2002	2064	
F7250-300SHP	10"	3517	53	211	492	886	1336	1934	2638	3411	3517	
F7300-300SHP	12"	4837	73	290	677	1219	1838	2660	3628	4692	4837	

Maximum Dimensions (Inches)

Valve	Size	C _v 90°	A	B	C	D(Max)	BHC	No. of Holes	Lug Bolt	Actuator	Close-Off (PSI)	
F750-300SHP	2"	102	5.00	6.75	6.75	15.50	5.00	8	5/8-11 UNC	2*GK	285	Electronic Fail-Safe
F765-300SHP	2½"	146	5.50	7.38	7.38	16.00	5.88	8	3/4-10 UNC		285	
F780-300SHP	3"	228	6.00	7.92	7.92	16.25	6.63	8	3/4-10 UNC		285	
F7100-300SHP	4"	451	7.00	9.13	9.13	18.00	7.88	8	3/4-10 UNC		150	
F750-300SHP	2"	102	5.00	6.75	6.75	15.50	5.00	8	5/8-11 UNC	2*GM	285	Electronic Fail-Safe
F765-300SHP	2½"	146	5.50	7.38	7.38	16.00	5.88	8	3/4-10 UNC		285	
F780-300SHP	3"	228	6.00	7.92	7.92	16.25	6.63	8	3/4-10 UNC		285	
F7100-300SHP	4"	451	7.00	9.13	9.13	18.00	7.88	8	3/4-10 UNC		150	
F750-300SHP	2"	102	5.00	6.75	6.75	14.00	4.75	8	5/8-11 UNC	PR/PK	600	Non-Spring Return Electronic Fail-Safe (K)
F765-300SHP	2½"	146	5.50	7.38	7.38	14.50	5.50	8	3/4-10 UNC	PR/PK	600	
F780-300SHP	3"	228	6.00	7.92	7.92	15.00	6.00	8	3/4-10 UNC	PR/PK	600	
F7100-300SHP	4"	451	7.00	9.13	9.13	16.00	7.50	8	3/4-10 UNC	PR/PK	400	
F7125-300SHP	5"	714	8.00	10.25	10.25	24.25	8.50	8	3/4-10 UNC	SY4...	600	
F7150-300SHP	6"	1103	8.50	10.79	10.79	24.75	9.50	12	3/4-10 UNC	SY4...	600	
F7200-300SHP	8"	2064	10.00	12.88	12.88	32.00	11.75	12	7/8-9 UNC	SY4... SY5...	400 600	
F7250-300SHP	10"	3517	11.50	14.75	14.75	33.00	14.25	16	1-8 UNC	SY7... SY4...	600 150	
F7300-300SHP	12"	4837	13.00	16.62	16.62	35.00	17.00	16	1 1/8-8 UNC	SY7... SY8...	400 600	

Dimensions "A, B and C" do not include flange gaskets. (3 required per valve)

Application Notes

- Valves are rated at 725 psi differential pressure in the closed position @ 100°F media temperature.
- Valves are furnished with lugs tapped for use between ANSI Class 250/300 flanges conforming to ANSI B16.5 Standards.
- 3-way assemblies are furnished assembled with Tee, calibrated and tested, ready for installation. All 3 way assemblies require the customer to specify the 3-way configuration code prior to order entry to guarantee correct placement of valves and actuator(s) on the assembly.
- Dimension "D" allows for actuator(s) removal without the need to remove the valve from the pipe.
- Weather shields are available, dimensional data furnished upon request.
- Dual actuated valves have single actuators mounted on each valve shaft.
- Flange gaskets (3 required, not provided with valve) MUST be used between valve and ANSI flange.
- Flange bolts are not included with the valve. These are furnished by others.

Dimensions

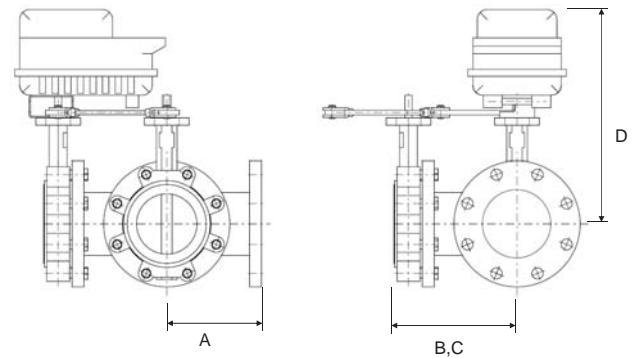

D104



5-year warranty



Technical data

Electrical data	Nominal voltage	AC 24...240 V / DC 24...125 V
	Nominal voltage frequency	50/60 Hz
	Power consumption in operation	20 W
	Power consumption in rest position	6 W
	Transformer sizing	20 VA @ AC/DC 24 V (class 2 power source), 23 VA @ AC/DC 120 V, 52 VA @ AC 230 V
	Auxiliary switch	2 x SPDT, 3 A resistive (0.5 A inductive) @ AC 250 V, 1 x 10° / 1 x 0...90° (default setting 85°)
	Switching capacity auxiliary switch	3 A resistive (0.5 A inductive) @ AC 250 V
	Electrical Connection	Terminal blocks, (PE) Ground-Screw
	Overload Protection	electronic throughout 0...90° rotation
Functional data	Communicative control	BACnet MS/TP Modbus RTU MP-Bus
	Operating range Y	2...10 V
	Operating range Y note	4...20 mA
	Input Impedance	100 kΩ for 2...10 V (0.1 mA), 500 Ω for 4...20 mA, 1500 Ω for On/Off
	Operating range Y variable	Start point 0.5...30 V End point 2.5...32 V
	Options positioning signal	variable (VDC, on/off, floating point)
	Position feedback U	2...10 V
	Position feedback U note	Max. 0.5 mA
	Position feedback U variable	VDC variable
	Direction of motion motor	reversible with app
	Manual override	7 mm hex crank, supplied
	Angle of rotation	90°
	Running Time (Motor)	default 35 s, variable 30...120 s
	Running time motor variable	30...120 s
	Noise level, motor	68 dB(A)
	Position indication	integral pointer
	Passive sensor inputs	2x (Pt1000, Ni1000, NTC10k2)
Safety data	Degree of protection IEC/EN	IP66/67
	Degree of protection NEMA/UL	NEMA 4X
	Enclosure	UL Enclosure Type 4X
	Agency Listing	cULus acc. to UL60730-1A/-2-14, CAN/CSA E60730-1:02, CE acc. to 2014/30/EU and 2014/35/EU
	Quality Standard	ISO 9001
	Ambient temperature	-22...122°F [-30...50°C]

Safety data	Storage temperature	-40...176°F [-40...80°C]
	Ambient humidity	Max. 100% RH
	Servicing	maintenance-free
Weight	Weight	13 lb [5.9 kg]
Materials	Housing material	Die cast aluminium and plastic casing

Product features

- Application** PR Series valve actuators are designed with an integrated linkage and visual position indicators. For outdoor applications, the installed valve must be mounted with the actuator at or above horizontal. For indoor applications the actuator can be in any location including directly under the valve.
- Operation** The PR series actuator provides 90° of rotation and a visual indicator shows the position of the valve. The PR Series actuator uses a low power consumption brushless DC motor and is electronically protected against overload. A universal power supply is furnished to connect supply voltage in the range of AC 24...240 V and DC 24...125 V. Included is a smart heater with thermostat to eliminate condensation. Two auxiliary switches are provided; one set at 10° open and the other is field adjustable. Running time is field adjustable from 30...120 seconds by using the Near Field Communication (NFC) app and a smart phone.
- †Use 60°C/75°C copper wire size range 12...28 AWG, stranded or solid. Use flexible metal conduit. Push the listed conduit fitting device over the actuator's cable to butt against the enclosure. Screw in conduit connector. Jacket the actuators input wiring with listed flexible conduit. Properly terminate the conduit in a suitable junction box. Rated impulse Voltage 4000 V. Type of action 1. Control pollution degree 3.

Accessories

Gateways	Description	Type
	Gateway MP to BACnet MS/TP	UK24BAC
	Gateway MP to LonWorks	UK24LON
	Gateway MP to Modbus RTU	UK24MOD
Electrical accessories	Description	Type
	Service Tool, with ZIP-USB function, for programmable and communicative Belimo actuators, VAV controller and HVAC performance devices	ZTH US
Mechanical accessories	Description	Type
	Hand crank for PR, PKR, PM	ZG-HND PR
Service tools	Description	Type
	Connection cable 10 ft [3 m], A: RJ11 6/4 ZTH EU, B: 3-pin Weidmüller and supply connection	ZK4-GEN
	Service Tool, with ZIP-USB function, for programmable and communicative Belimo actuators, VAV controller and HVAC performance devices	ZTH US

Electrical installation

- Meets cULus requirements without the need of an electrical ground connection.
- Universal Power Supply (UP) models can be supplied with 24 V up to 240 V.
- Disconnect power.
- Provide overload protection and disconnect as required.
- Two built-in auxiliary switches (2x SPDT), for end position indication, interlock control, fan startup, etc.
- Only connect common to negative (-) leg of control circuits.
- Actuators may be controlled in parallel. Current draw and input impedance must be observed.
- Warning! Live electrical components!**

During installation, testing, servicing and troubleshooting of this product, it may be necessary to work with live electrical components. Have a qualified licensed electrician or other individual who has been properly trained in handling live electrical components perform these tasks. Failure to follow all electrical safety precautions when exposed to live electrical components could result in death or serious injury.

Wiring diagrams

On/Off

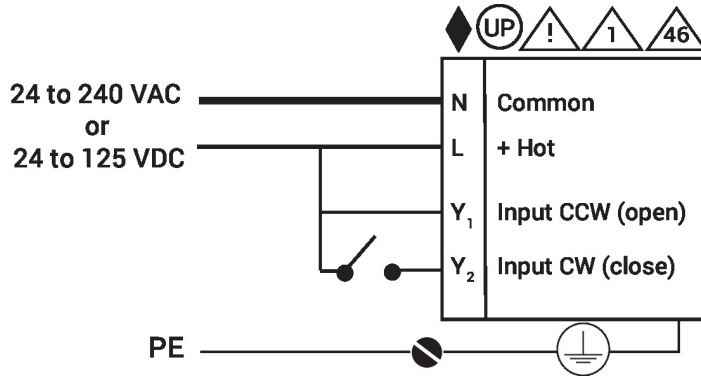

On/Off

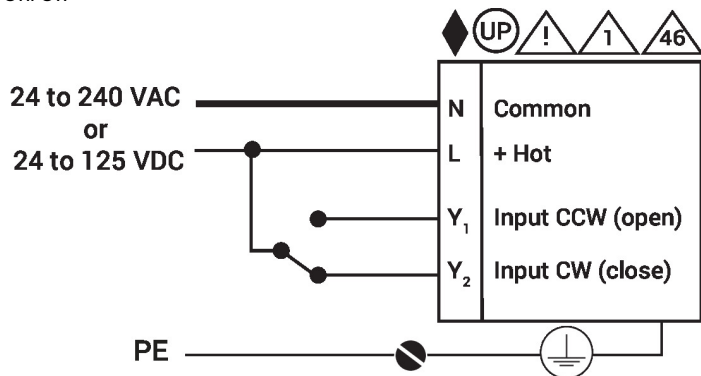

BACnet

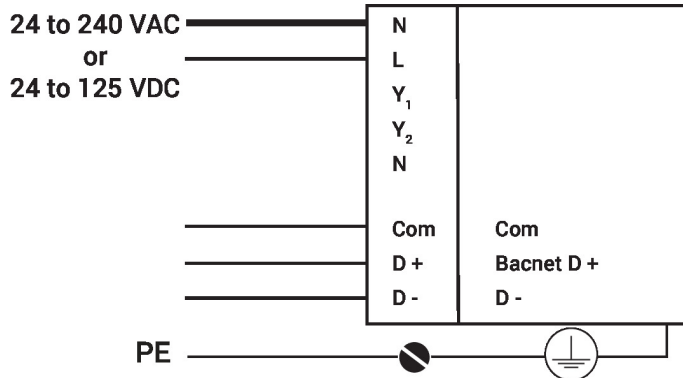

Modulating

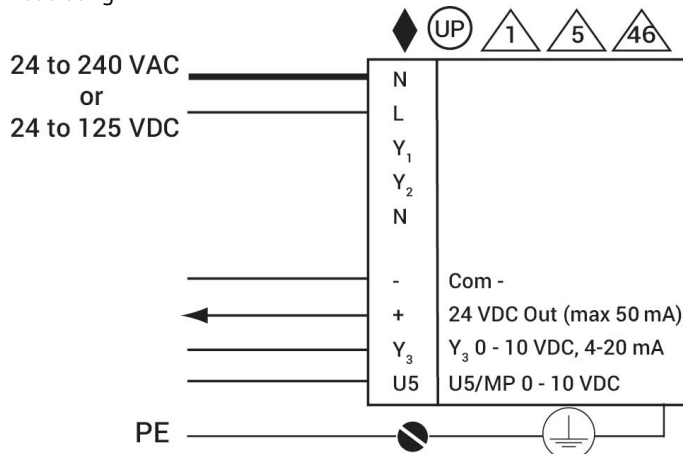

Floating Point

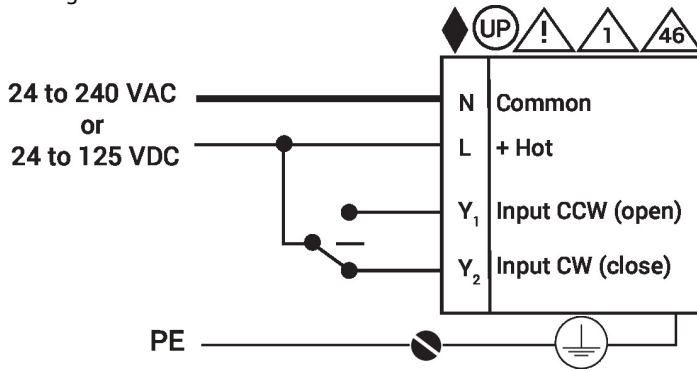

Temperature Sensors

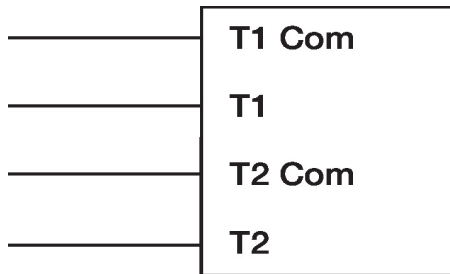

Auxiliary Switches

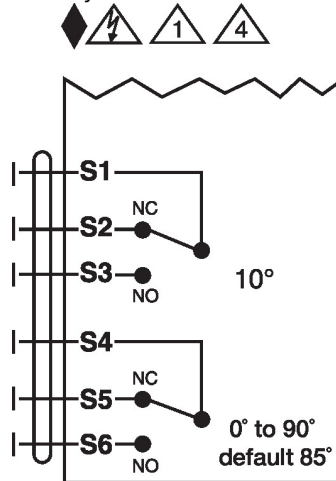

Dimensions

Dimensional drawings

