

On/Off, Spring Return, 350°F [177°C] for half an hour, 15 s Cycle Time

- Torque 8 Nm / from 32...350°F [0...177°C]
- Nominal voltage AC/DC 24 V
- Control On/Off



5-year warranty



Technical data

Electrical data	Nominal voltage	AC/DC 24 V
	Nominal voltage frequency	50/60 Hz
	Power consumption in operation	27 VA
	Power consumption in rest position	3 W, 6.5 VA, End stop 55 VA, 2.5 A slow blow fuse *
	Transformer sizing	40 VA (class 2 power source)
	Electrical Connection	18 GA, 3 ft [1 m], 2 color coded wires
	Overload Protection	electronic throughout 0...95° rotation
	Electrical Protection	actuators are double insulated
Functional data	Torque motor	70 in-lb [8 Nm] from 32...350°F [0...177°C]
	Direction of motion motor	selectable by ccw/cw mounting
	Direction of motion fail-safe	reversible with cw/ccw mounting
	Angle of rotation	95°
	Running Time (Motor)	15 s / 90°
	Running time motor note	between 32...350°F [0...177°C], <15 s at rated voltage & torque
	Running time fail-safe	15 s
	Noise level, motor	45 dB(A)
	Noise level, fail-safe	62 dB(A)
	Shaft Diameter	1/2...1.05" round, centers on 1/2" and 3/4" with insert, 1.05" without insert
Safety data	Position indication	Mechanical
	Degree of protection IEC/EN	IP40
	Degree of protection NEMA/UL	NEMA 1
	Enclosure	UL Enclosure Type 1
	Agency Listing	cULus listed to UL873 and CAN/CSA C22.2 No.24, UL 2043 Listed for air plenum installation per NEC 300.22 and IMC Section 602 NYC Department of Buildings MEA 197-07-M California State Fire Marshal Listing 3210-1593:101
	Quality Standard	ISO 9001
	Ambient temperature	32...122°F [0...50°C]
	Storage temperature	-40...176°F [-40...80°C]
	Ambient humidity	Max. 95% RH, non-condensing
	Servicing	maintenance-free
Weight	Weight	5.8 lb [2.8 kg]
Materials	Housing material	galvanized steel

Materials Gears steel, permanently lubricated

Footnotes † UL File XAPX.E108966

Safety notes



- * Neither UL nor Belimo require local over-current protection. The FSNF actuators draw higher peak current when driving against any type of stop. If used, this requires the value of a local fuse or breaker to be increased to avoid nuisance opening or tripping. A 2.5 A slow blow should be used for AC 24 V. A 0.5 A slow blow should be used for AC 120 V. A 0.25 A slow blow should be used for 230 V and a 0.3 A slow blow for AC 208 V. Transformers: Note that while a 24 V 100 VA transformer would handle 2 actuators, a 4 A breaker or plug fuse is insufficient. A 5 A slow blow would be required.
- Belimo Fire & Smoke actuators have passed the AMCA 520 and UL 555S Long Term Holding test. No special cycling is required during prolonged periods when actuator is driven open and held there. Periodic testing of dampers and actuators per local codes and NFPA 80 and NFPA 105 are required.
- The actuator contains no components which the user can replace or repair. A 1/2" threaded connector is standard. FSNFxx-FC models have a 3/8" Flex Connector. Other than the connector, these actuators are identical to the conduit connector version.

Product features

- Application** The FS series of spring-return actuators are designed for the operation of UL555 and UL555S listed fire/smoke dampers in ventilation and air-conditioning systems.
- Operation** The actuator is mounted in its fail safe position with the damper blade(s) typically closed. Upon applying power, the actuator drives the damper to the open position. The internal spring is tensioned at the same time. If the power supply is interrupted, the spring moves the damper back to its fail-safe position.
- Typical specification** All smoke and combination fire and smoke dampers shall be provided with Belimo FSTF, FSLF, FSNF, or FSAF series actuators. All substitutions must be approved before submission of bid. Damper and actuator shall have UL555S Listing for 250°F and/or 350°F. Actuator shall have been tested to UL2043 per requirements of IMC 602.2 and NEC 300.22 (c). Where position indication is required -S models with auxiliary switches shall be provided.

Accessories

Electrical accessories	Description	Type
	Thermoelectric tripping device, Duct inside temperature 165°F	BAE165 US
	Auxiliary switch 2 x SPDT	S2A-F US

Mechanical accessories	Description	Type
	Anti-rotation bracket, for AF / NF	AF-P
	End stop indicator for AF / NF	IND-AF2
	Shaft clamp for AF..	K4-1 US
	Classic AF/NF crankarm for Jackshaft to 1.05".	KH-AF-1 US
	Actuator arm, clamping range Ø10...20 mm	KH-AF
	Push rod for KG6 & KG8 ball joints (36" L, 5/16" diameter).	SH8
	Angle of rotation limiter for Classic AF/NF.	ZDB-AF2 US
	<p>17" Mounting Bracket for AF,NF,GM,AM,SM</p>	ZG-100
	<p>Mounting Bracket: AF,NF,LF,GM,AM,NM,SM</p>	ZG-101
	Classic AF/NF crankarm adaptor kit.	ZG-AF US
	Classic AF/NF crankarm adaptor kit with ZG-108.	ZG-AF108
	Damper clip for damper blade, 3.5" width.	ZG-DC1
	Damper clip for damper blade, 6" width.	ZG-DC2
	Weather shield 330x203x152 mm [13x8x6"] (LxBxH)	ZS-100
	Weather shield 406x213x102 mm [16x8-3/8x4"] (LxWxH)	ZS-150
	Explosion proof housing 406x254x164 mm [16x10x6.435"] (LxBxH), UL and CSA, Class I, Zone 1&2, Groups B, C, D, (NEMA 7), Class III, Hazardous (classified) Locations	ZS-260
	Weather shield 438x222x140 mm [17-1/4x8-3/4x5-1/2"] (LxBxH), NEMA 4X, with mounting brackets	ZS-300

Electrical installation
INSTALLATION NOTES

- Provide overload protection and disconnect as required.
- Actuators may be powered in parallel. Power consumption must be observed.
- Ground present on some models.
- Meets cULus requirements without the need of an electrical ground connection.

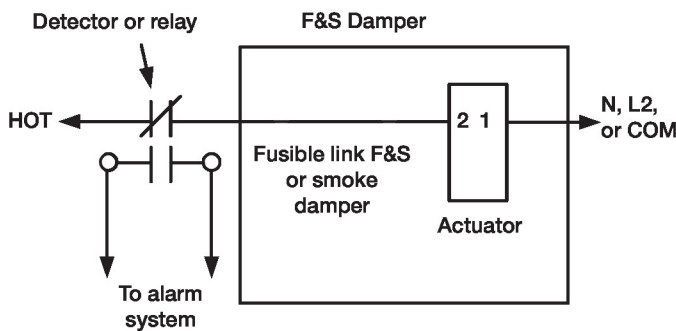

Typical smoke or fusible link damper wiring

Wiring diagrams

AC/DC 24 V

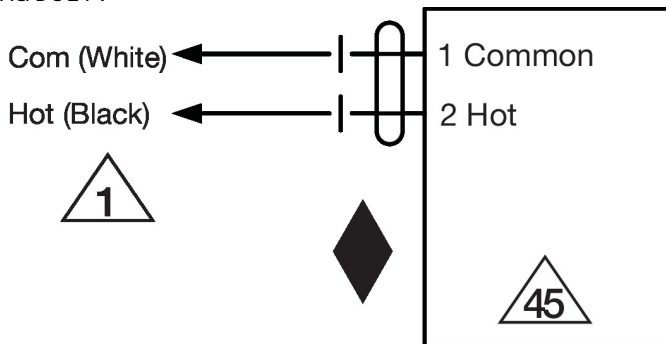

Typical containment damper control wiring
Detector or relay F&S Damper

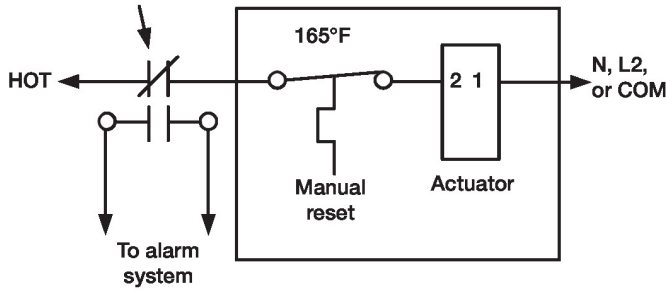

Typical smoke or fusible link damper wiring
Detector or relay F&S Damper

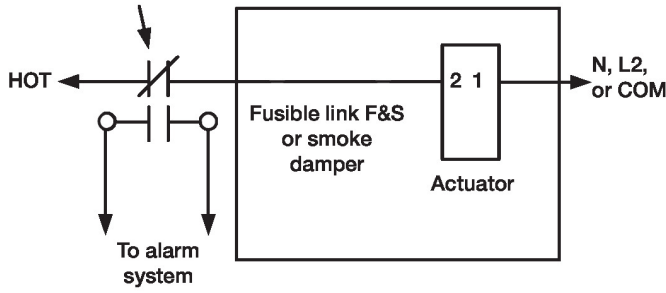

Parallel Actuator Wiring

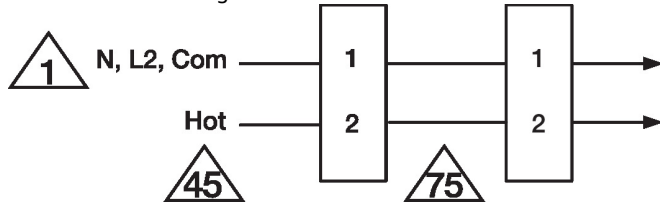

Dimensions

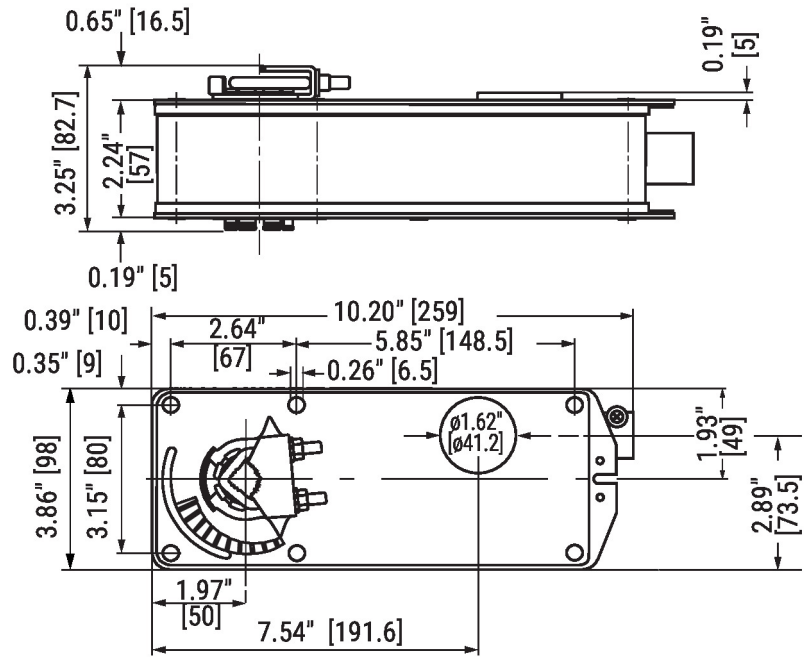

Standard:

1/2" to 1.05"

Optional*

3/8" to 3/4"

*with K4 US clamp