

- Torque motor 360 in-lb [40 Nm]
- Nominal voltage AC/DC 24 V
- Control modulating, Cloud, communicative, Hybrid
- Conversion of sensor signals
- Ethernet 10/100 Mbit/s, TCP/IP, integrated web server
- Communication via BACnet IP, Modbus TCP and Cloud



5-year warranty

Technical data

Electrical data	Nominal voltage	AC/DC 24 V
	Nominal voltage frequency	50/60 Hz
	Nominal voltage range	AC 19.2...28.8 V / DC 21.6...28.8 V
	Power consumption in operation	11 W
	Power consumption in rest position	3 W
	Power consumption for wire sizing	21 VA
	Transformer sizing	21 VA (class 2 power source)
	Parallel operation	Yes (note the performance data)
	Electrical Connection	18 GA appliance cable, 1/2" conduit connector and RJ45 socket (ethernet)
	Overload Protection	electronic throughout 0...95° rotation
Functional data	Torque motor	360 in-lb [40 Nm]
	Communicative control	Cloud BACnet IP Modbus TCP
	Operating range Y	2...10 V
	Operating range Y note	Hybrid via 2...10 V
	Input Impedance	34 kΩ
	Operating range Y variable	0.5...10 V
	Bridging time (PF)	2 s
	Pre-charging time	5...20 s
	Position accuracy	±5%
	Direction of motion motor	selectable with switch 0/1
	Direction of motion fail-safe	reversible with switch
	Manual override	external push button
	Angle of rotation	95°
	Angle of rotation note	adjustable with mechanical stop
	Running Time (Motor)	150 s / 90°
	Running time motor variable	70...220 s
	Running time fail-safe	<35 s
	Adaptation Setting Range	manual
	Noise level, motor	52 dB(A)
Noise level, fail-safe	61 dB(A)	
Position indication	Mechanically, pluggable	
Safety data	Protection class IEC/EN	III, Safety Extra-Low Voltage (SELV)
	Degree of protection IEC/EN	IP54

Safety data	Degree of protection note	IP54 when using protective cap or protective grommet for RJ45 socket
	Degree of protection NEMA/UL	NEMA 1
	Enclosure	UL Enclosure Type 1
	EMC	CE according to 2014/30/EU
	Agency Listing	cULus acc. to UL60730-1A/-2-14, CAN/CSA E60730-1:02, CE acc. to 2014/30/EU and 2014/35/EU; Listed to UL 2043 - suitable for use in air plenums per Section 300.22(c) of the NEC and Section 602.2 of the IMC
	Quality Standard	ISO 9001
	Mode of operation	Type 1
	Ambient temperature	-22...122°F [-30...50°C]
	Storage temperature	-40...176°F [-40...80°C]
	Ambient humidity	Max. 95% RH, non-condensing
	Servicing	maintenance-free
	Materials	Housing material

Safety notes



- The device must not be used outside the specified field of application, especially not in aircraft or in any other airborne means of transport.
- Outdoor application: only possible in case that no (sea) water, snow, ice, insolation or aggressive gases interfere directly with the actuator and that is ensured that the ambient conditions remain at any time within the thresholds according to the data sheet.
- Only authorized specialists may carry out installation. All applicable legal or institutional installation regulations must be complied during installation.
- The device may only be opened at the manufacturer's site. It does not contain any parts that can be replaced or repaired by the user.
- Cables must not be removed from the device.
- To calculate the torque required, the specifications supplied by the damper manufacturers concerning the cross-section, the design, the installation situation and the ventilation conditions must be observed.
- The device contains electrical and electronic components and must not be disposed of as household refuse. All locally valid regulations and requirements must be observed.

Product features

Mode of operation	<p>The actuator is controlled via the Cloud, BACnet IP or Modbus TCP and drives to the position defined by the control signal. Various data points can be written and read via the same interfaces.</p> <p>Hybrid mode:</p> <p>The actuator receives its analog control signal from the higher level controller and drives to the position defined. Using the Cloud, BACnet IP or Modbus TCP, various data points can be read and with the exception of the control signal written.</p>
Converter for sensors	<p>Connection option for two sensors (passive sensor, active sensor or switching contact). The actuator serves as an analog/digital converter for the transmission of the sensor signal to the higher level system.</p>

Communication The configuration can be carried out through the integrated web server (RJ45 connection to the web browser), by communicative means or via the Cloud.
Additional information regarding the integrated web server can be found in the separate documentation.

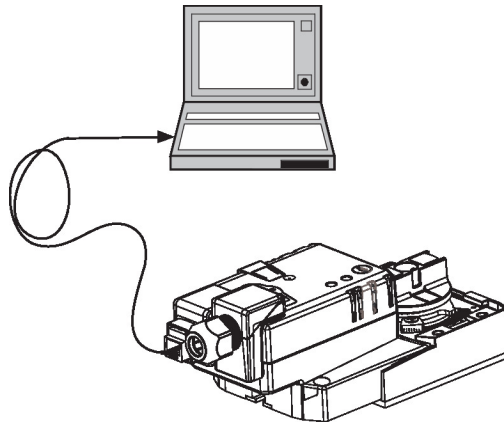
"Peer to Peer" connection
http://belimo.local:8080
The Notebook must be set to "DHCP".
Make sure that only one network connection is active.
Standard IP address:
http://192.168.0.10:8080
Static IP address
Password (read-only):
User name: «guest»
Password: «guest»



- Positioning signal inversion** This can be inverted in cases of control with an analog positioning signal. The inversion causes the reversal of the standard behavior, i.e. for control signal 0%, the actuator is opened to max and for control signal 100%, the actuator is closed.
- Simple direct mounting** Simple direct mounting on the damper shaft with a universal shaft clamp, supplied with an anti-rotation device to prevent the actuator from revolving.
- Data recording** The recorded data (integrated data recording for 13 months) can be used for analytical purposes.
Download csv files via web browser.
- Manual override** Manual override with push-button possible (the gear is disengaged for as long as the button is pressed or remains locked).
- Adjustable angle of rotation** Adjustable angle of rotation with mechanical end stops.
- High functional reliability** The actuator is overload protected, requires no limit switches and automatically stops when the end stop is reached.
- Home position** The first time the supply voltage is switched on, i.e. at the time of commissioning, the actuator carries out an adaptation, which is when the operating range and position feedback adjust themselves to the mechanical setting range.
The actuator then moves into the position defined by the positioning signal.
- Adaptation and synchronisation** An adaptation can be triggered manually by pressing the "Adaptation" button. Both mechanical end stops are detected during the adaptation (entire setting range).
The actuator then moves into the position defined by the positioning signal.

Accessories

Electrical accessories	Description	Type
	Grommet for RJ connection module, Multipack 50 pcs.	Z-STRJ.1
Service tools	Description	Type
	Connection cable 16 ft [5 m], A: RJ11 6/4 ZTH EU, B: 6-pin for connection to service socket	ZK1-GEN
	Service Tool, with ZIP-USB function, for programmable and communicative Belimo actuators, VAV controller and HVAC performance devices	ZTH US

Electrical installation



Supply from isolating transformer.
Parallel connection of other actuators possible. Observe the performance data.

Functions



The connection diagrams shows connections for the first sensor on terminal S1, while the second sensor can be connected identically on terminal S2.
Parallel use of different sensor types is permitted.
For hybrid operation, S1 is used for the control signal Y and must be configured as an active sensor.

Dimensions

∅ 1/4" to 3/4" [6 to 20]

□ 5/16" to 3/4" [8 to 26]

