

5-year warranty



Type overview

Type	DN
Z2050QPT-F	15

Technical data

Functional data	Valve Size	0.5" [15]
	Noise level, Motor	dB(A)
	Fluid	chilled or hot water, up to 60% glycol
	Fluid Temp Range (water)	36...212°F [2...100°C]
	Body Pressure Rating	360 psi
	Close-off pressure Δps	200 psi
	Flow characteristic	equal percentage
	Servicing	maintenance-free
	Flow Pattern	2-way
	Leakage rate	0%
	Controllable flow range	75°
Materials	Valve body	forged brass
	Spindle	stainless steel
	Seat	PTFE
	Characterized disc	incorporated into the ball
	Diaphragm	EPDM
	Pipe connection	NPT female ends
	Ball	stainless steel
Suitable actuators	Non-Spring	CQB
	Electrical fail-safe	CQKB(X)

Safety notes



- WARNING: This product can expose you to lead which is known to the State of California to cause cancer and reproductive harm. For more information go to www.p65warnings.ca.gov
- If temperature exceeds 212°F operating range due to a boiler control failure the valve will safely contain the hot water but manufacturers product warranty becomes invalid. Valve and actuator replacement is at the expense of others.

Product features

Application The PIQCV zone valves with its pressure independent technology are suited for large commercial buildings where higher close-off and dynamic balancing is required. Common applications include unit ventilators, fan coil units, VAV reheat coils, fin tube casing, radiant panels and duct coils. The valve fits in space restricted areas and can be assembled without the use of tools.

Dimensions

Type	DN
Z2050QPT-F	15

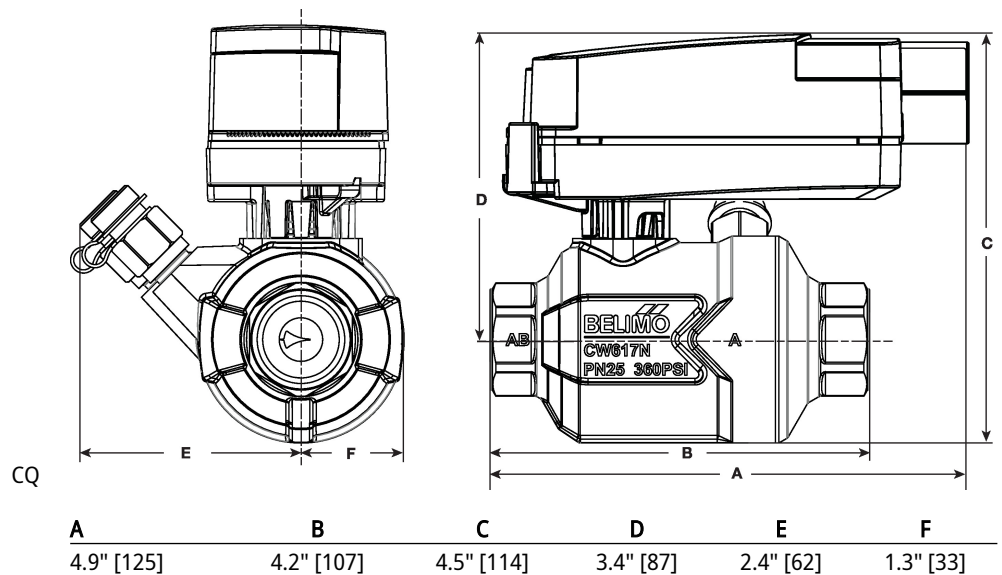
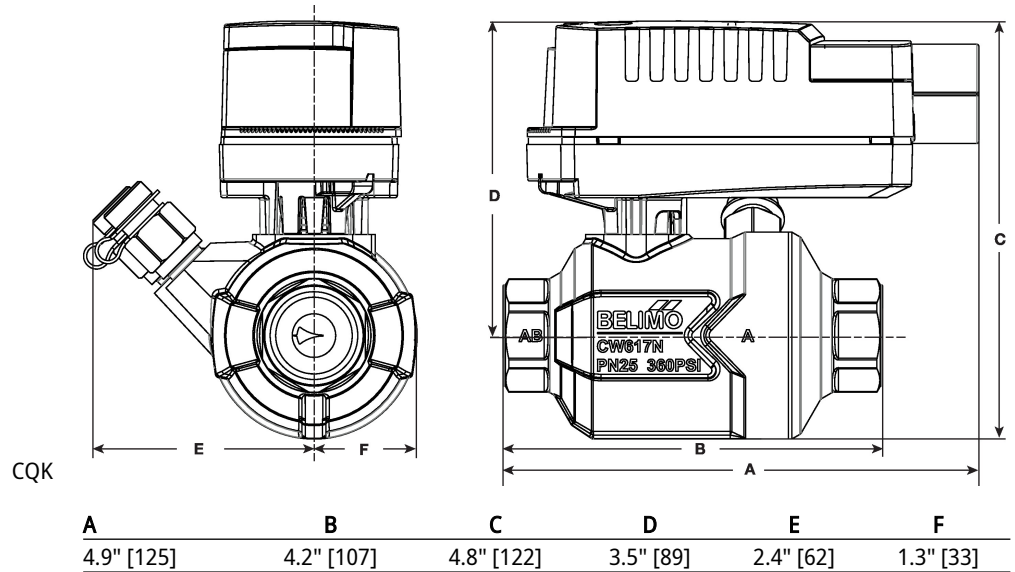

- Nominal voltage AC 100...240 V
- Control On/Off
- Position feedback

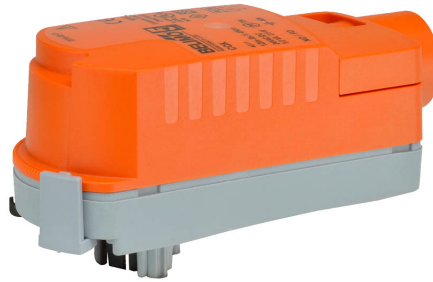

5-year warranty



Technical data

Electrical data	Nominal voltage	AC 100...240 V
	Nominal voltage frequency	50/60 Hz
	Power consumption in operation	2.5 W
	Power consumption in rest position	0.5 W
	Power consumption for wire sizing	5 VA
	Transformer sizing	7 VA (class 2 power source)
	Electrical Connection	18 GA appliance cable, 3 ft [1 m], with 1/2" conduit connector
	Overload Protection	electronic throughout 0...90° rotation
Functional data	Bridging time (PF)	2 s
	Pre-charging time	5...20 s
	Angle of rotation	90°
	Angle of rotation note	adjustable with mechanical stop
	Running Time (Motor)	75 s / 90°
	Running time fail-safe	<60 s
	Noise level, motor	35 dB(A)
	Noise level, fail-safe	35 dB(A)
Position indication	pointer	
Safety data	Degree of protection IEC/EN	IP40
	Degree of protection NEMA/UL	NEMA 2
	Enclosure	UL Enclosure Type 2
	Agency Listing	cULus acc. to UL60730-1A/-2-14, CAN/CSA E60730-1:02, CE acc. to 2014/30/EU and 2014/35/EU; Listed to UL 2043 - suitable for use in air plenums per Section 300.22(c) of the NEC and Section 602.2 of the IMC
	Quality Standard	ISO 9001
	Ambient temperature	1.7...40°C
	Storage temperature	-40...176°F [-40...80°C]
	Ambient humidity	Max. 95% RH, non-condensing
	Servicing	maintenance-free
	Materials	Housing material

Product features

Application Electrical fail-safe On/Off ZoneTight actuator.
 Valve selection should be done in accordance with the flow parameters and system specifications.
 The actuator is mounted directly to the valve without the need for tools or additional linkage.
 The actuator operates in response to AC 100...240 V. Angle of rotation is adjustable with the integrated mechanical stop.

Electrical installation

INSTALLATION NOTES

- Actuators with appliance cables are numbered.
- Provide overload protection and disconnect as required.
- Actuators may be connected in parallel. Power consumption and input impedance must be observed.
- Meets cULus requirements without the need of an electrical ground connection.
- Warning! Live electrical components!**
 During installation, testing, servicing and troubleshooting of this product, it may be necessary to work with live electrical components. Have a qualified licensed electrician or other individual who has been properly trained in handling live electrical components perform these tasks. Failure to follow all electrical safety precautions when exposed to live electrical components could result in death or serious injury.

Wiring diagrams

On/Off

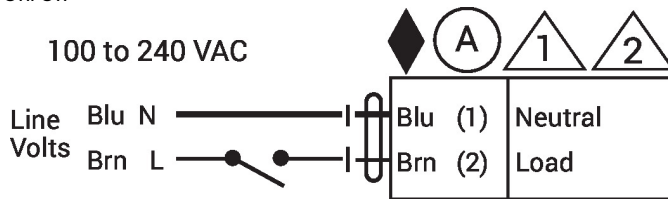

Functions	A	
0%		
100%		
Fail Position	0%	Close

Dimensions