

SERIES PL™ Booster Pumps

INSTALLER: PLEASE LEAVE THIS MANUAL FOR THE OWNER'S USE.

NOTE: Bell & Gossett recommends Bronze Booster Pumps be used for pumping potable water.

This pump is nonsubmersible, for indoor use only.

SAFETY INSTRUCTIONS

This safety alert symbol will be used in this manual and on the pump safety instructions decal to draw attention to safety related instructions. When used, the safety alert symbol means ATTENTION! BECOME ALERT! YOUR SAFETY IS INVOLVED! FAILURE TO FOLLOW THE INSTRUCTIONS MAY RESULT IN A SAFETY HAZARD.

Your Series PL™ Booster Pump should have the warning/caution label and nonsubmersible warning label (Fig. 1) displayed on the pump conduit box. If this warning and caution is missing or illegible, contact your local Bell & Gossett Representative for a replacement.

DESCRIPTION

The Series PL™ Booster Pump features permanently lubricated bearings, non-overloading permanent split capacitor motor with thermal protection and quiet operating construction.

OPERATIONAL LIMITS

These pumps are designed to pump liquids compatible with their iron or bronze body construction.

Maximum Working Pressure: 150 psi (10 bar)
Maximum Operating Temperature: 225°F (107°C)
Electrical Rating: 115V, 60 Hz, 1PH
230V, 60 Hz, 1PH
277V, 60 Hz, 1PH

Do not exceed these values.

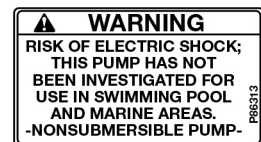

FIG. 1

PUMP APPLICATION

The Series PL™ Booster Pump may be used for water circulating applications in hydronic and solar systems.

It has not been investigated, nor is it intended for use in swimming pool and marine areas.

SAFETY REQUIREMENTS

MECHANICAL SAFETY



WARNING: EXCESSIVE SYSTEM PRESSURE HAZARD

The maximum working pressure of the pump is listed on the nameplate – **DO NOT EXCEED THIS PRESSURE.** Failure to follow these instructions could result in serious personal injury, death and/or property damage.



WARNING: EXCESSIVE PRESSURE HAZARD – VOLUMETRIC EXPANSION

The heating of water and other fluids causes volumetric expansion. The associated forces may cause failure of system components and the release of high temperature fluids. This can be prevented by installing properly sized and located expansion tanks and pressure relief valves. Failure to follow these instructions could result in serious personal injury, death and/or property damage.

THERMAL SAFETY



WARNING: EXTREME TEMPERATURE HAZARD

If the pump, motor, or piping are operating at extremely high or low temperature, guarding or insulation is required. Failure to follow these instructions could result in serious personal injury, death and/or property damage.

ELECTRICAL SAFETY



WARNING: ELECTRICAL SHOCK HAZARD

Electrical connections are to be made by a qualified electrician in accordance with all applicable codes, ordinances and good practices. Failure to follow these instructions could result in serious personal injury, death and/or property damage.



WARNING: ELECTRICAL GROUNDING HAZARD

Adequate electrical grounding is required for the safe operation of B&G Pumps. The use of grounded metal conduit assures this requirement. If the means of connection to the supply-connection box (wiring compartment) is other than grounded metal conduit, ground the pump back to the service by connecting a copper conductor at least the size of the circuit conductors supplying the pump to the green grounding screw provided within the wiring compartment. Failure to follow these instructions could result in serious personal injury, death and/or property damage.



WARNING: RISK OF ELECTRIC SHOCK

Do not install this pump in swimming pool or marine areas. Failure to follow these instructions could result in serious personal injury, death and/or property damage.

REMOVAL OF THE PUMP FROM EXISTING SYSTEM FOR REPLACEMENT



WARNING: ELECTRICAL SHOCK HAZARD

Disconnect and lockout the power before servicing. Failure to follow these instructions could result in serious personal injury or death.

1. Close the valves on the suction and discharge sides of the pump. If no valves have been installed, it may be necessary to drain the system.



WARNING: HOT WATER HAZARD

Before draining the system, allow water to cool to 100°F max. open the drain valve (take precautions against water damage) and leave the drain valve open until servicing is complete. Failure to follow these instructions could result in serious personal injury, death and/or property damage.



WARNING: ELECTRICAL SHOCK HAZARD

Be certain the electrical power is not present at the motor leads before continuing. Failure to follow these instructions could result in serious personal injury or death.

2. Loosen the conduit box cover screw and remove the cover.



WARNING: UNEXPECTED START-UP HAZARD

Single phase motors are equipped with automatic reset overload protectors. The pump can restart without warning. Disconnect and lockout power before servicing. Failure to follow these instructions could result in serious personal injury, death and/or property damage.

3. Disconnect the electrical supply lines to the pump.



WARNING: HIGH PRESSURE HAZARD

Pressure may be present in the pump body. This pressure can be relieved by loosening the flange bolts and shifting the pump assembly slightly to allow the pressurized water to escape. Failure to follow these instructions could result in serious personal injury or death.

4. Remove the flange bolts and nuts and then remove the pump from the piping.

PUMP INSTALLATION

Locate the pump so there is sufficient room for inspection, maintenance and service. Bell & Gossett recommends the installation of service valves on the suction and discharge of all pumps to facilitate servicing or replacement of the pump without draining the system.

Install suction and discharge flanges on the pipe ends. The use of teflon tape sealer or a high quality thread sealant is recommended.

Be sure to minimize any pipe-strain on the pump. Support the suction and discharge piping by the use of pipe hangers near the pump. Line up the vertical and horizontal piping so that

the bolt-holes in the pump flanges match the bolt-holes in the pipe flanges. (DO NOT ATTEMPT TO SPRING THE SUCTION OR DISCHARGE LINES IN POSITION. THIS MAY RESULT IN UNWANTED STRESS IN THE PUMP BODY, FLANGE CONNECTIONS AND PIPING.) The code for Pressure Piping (ANSI B31.1) lists many types of supports available for various applications.

Bell & Gossett flange gaskets must be installed between the Series PL™ pump body flanges and the suction and discharge pipe flanges. Use $\frac{7}{16}$ " diameter x $1\frac{1}{2}$ " long capscrew and matching nut to connect the pump to the flanges.

WARNING: HOT WATER HAZARD
 When disassembling a gasketed joint, always use a new gasket upon reassembly. NEVER RE-USE OLD GASKETS. Failure to follow these instructions could result in serious personal injury, death and/or property damage.

WARNING: HOT WATER HAZARD
 Make sure that each flange gasket remains seated in the flange groove during and after installation. Failure to follow these instructions could result in serious personal injury, death and/or property damage.

Apply torque in even increments to both flange bolts until a value of 96-132 in-lbs. is reached. Both the suction and discharge flange bolts must be torqued in this manner.

WARNING: WATER LEAKAGE HAZARD
 To prevent leakage, make certain that the flange bolts have been adequately torqued. Failure to follow these instructions could result in serious personal injury and/or property damage.

WIRING INSTRUCTIONS

WARNING: ELECTRICAL SHOCK HAZARD
 Disconnect and lockout the power before making electrical connections. Failure to follow these instructions could result in serious personal injury or death.

- A. Loosen the screw securing the conduit box cover (wiring compartment), and remove the screw & cover.
- B. Attach the appropriate size connector to the hole on the side of the conduit box.
- C. Using a minimum size 14 AWG copper electrical wire (refer to your local code for wiring restrictions), wire the motor to a single phase power source as listed on the pump nameplate. See Fig. 3.
- D. Connect the ground wire to the inside of the conduit box with one of the green screws provided inside the box. See Fig. 4.

NOTE: Electrical supply and grounding wires must be suitable for at least 90°C (194°F).

NOTE: Series PL™ Booster Pumps are thermally protected and do not require external overload protection.

WARNING: ELECTRICAL SHOCK HAZARD
 Be certain that all connections are secure and the conduit box cover is closed before electrical power is connected. Failure to follow these instructions could result in serious personal injury, death and/or property damage.

SYSTEM PREPARATION

Prior to pump start up, closed heating and cooling systems should be cleaned, drained and refilled with clean water. System ph must be maintained between 7 and 9.

STARTUP

CAUTION: SEAL DAMAGE HAZARD
 Do not run pump dry, seal damage may occur. Failure to follow these instructions could result in property damage and/or moderate personal injury.

Do not start pump until the system has been filled and vented. Air should be vented from the system by means of an air vent located at a high point in the system, or by an alternate method. The system must be completely vented prior to pump operation. Do not run pumps dry. Pump operation without water circulation could result in pump and motor damage.

WARNING: HOT WATER LEAKAGE HAZARD
 Pressurize the body slowly while checking for leaks at all joints with gaskets. Failure to follow these instructions could result in serious personal injury and/or property damage.

MODE OF DISCHARGE

The Series PL™ pump can be installed to discharge up or down, horizontally, left or right, but the motor shaft must remain in the horizontal position, the arrow on the body must point in the direction of flow and the conduit box must be positioned on the top of the motor housing (see figure 2).

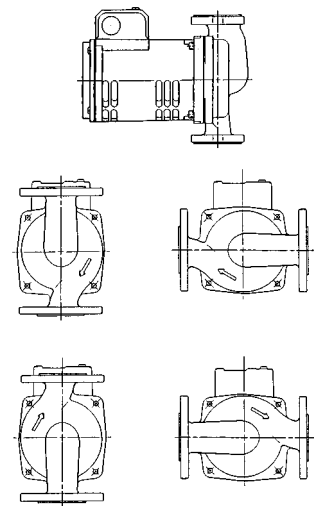

FIG. 2

PUMP BODY MAY BE ROTATED AS SHOWN, BUT CONDUIT BOX MUST REMAIN AT TOP.

TYPICAL WIRING INSTALLATION SCHEMATIC FOR 1Ø POWER SOURCE

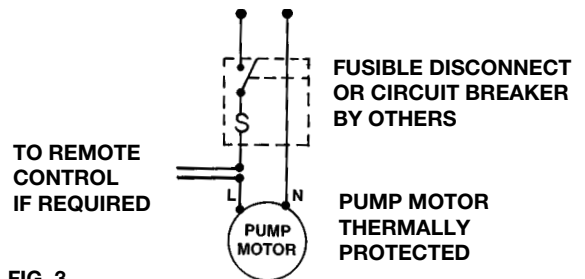

FIG. 3

CONDUIT BOX WIRING DETAIL

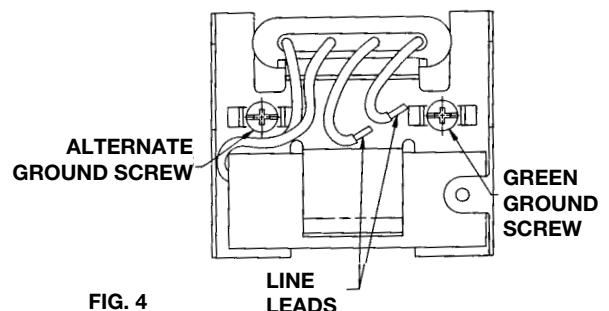

FIG. 4

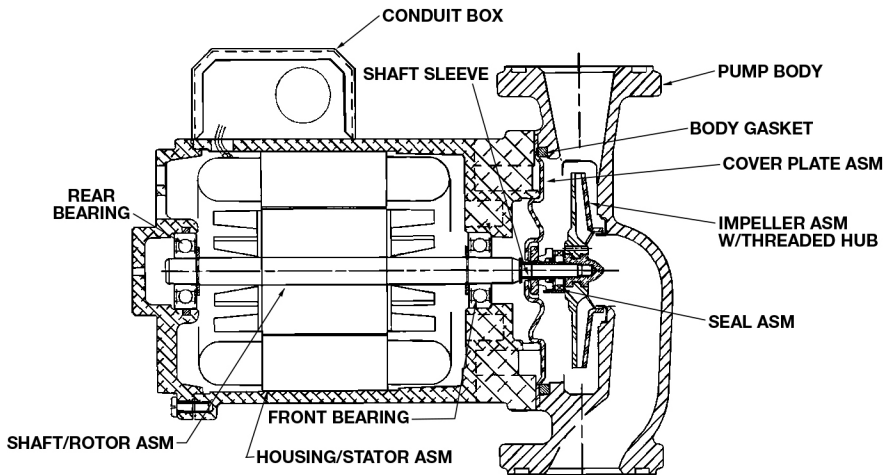
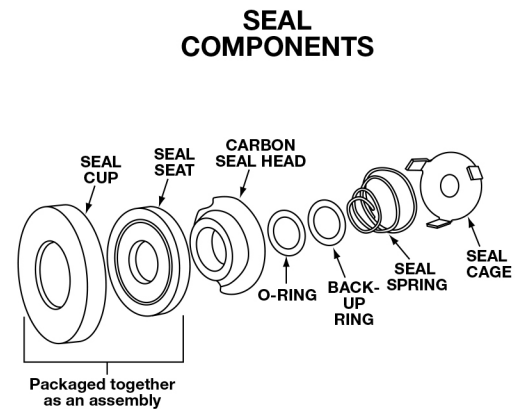

FIG. 5



INSTRUCTIONS FOR REPAIRING MECHANICAL SEAL

1. Follow steps 1 through 4 of section titled "REMOVAL OF PUMP FROM EXISTING SYSTEM FOR REPLACEMENT."
2. Loosen the four capscrews that hold the motor housing to the pump body. Remove these screws and remove the housing from the pump body.
3. Place the pump on a flat work surface and insert a screwdriver into one of the endplate ventilation slots until it engages one of the rotor cooling fins. While holding the rotor with the screwdriver, turn the impeller clockwise. Note that the impeller is molded around a metal hub with a left hand thread. Remove the impeller from the shaft.
4. Remove the seal assembly from the shaft by sliding it off the shaft sleeve.
5. Clean the seal seat with a clean rag and inspect for grooving or cracks. If it shows no grooving or cracks, it may be cleaned and reused.
6. If the seal seat is to be replaced, the face plate must be removed from the motor housing. Remove it by gently prying it away from the housing.
7. Remove the seal seat and cup. Lubricate the cup with soapy water and install new parts in the face plate recess.
8. Clean the shaft and sleeve before installing the new seal.
9. Slide the new carbon seal head onto the shaft sleeve until it contacts the seal seat. Slide the new "O-Ring" and back-up ring along the shaft sleeve until they fit inside the counter bore in the seal head. Place the seal spring between the back-up ring and the seal cage while positioning the seal cage flush with the end of the sleeve. Place the small end of the spring against the back-up ring. The three driving legs of the seal cage should engage the three slots on the seal head. While holding the rotor assembly with the screwdriver, thread the impeller onto the shaft in a counter clockwise direction. Tighten the impeller with light hand pressure. Take care to avoid bending a rotor cooling fin or damaging the shaft sleeve.
10. Clean the recess in the pump body and install a new body gasket.
11. Install the pump in the body and secure with four capscrews. Apply torque evenly in a criss cross pattern in 40 in-lb (4.52 N•m) increments to a torque of 80 in-lb (9.04 N•m).
12. Reinstall into the system using new flange gaskets. For instructions, see sections "PUMP INSTALLATION" and "WIRING INSTRUCTIONS" on pages 2 and 3.

PERIODIC INSPECTION

Bell & Gossett Booster Pumps are designed to provide years of trouble free service. It is recommended that periodic inspections be made to check for potential problems with the

pump. If any leakage or evidence of leakage is present repair or replace the unit.

xylem
Let's Solve Water

Xylem Inc.
8200 N. Austin Avenue
Morton Grove, Illinois 60053
Phone: (847) 966-3700
Fax: (847) 965-8379
www.bellgossett.com

Bell & Gossett is a trademark of Xylem Inc. or one of its subsidiaries.
© 2013 Xylem Inc. P81884-I October 2013