

DEVICE INFORMATION

Identification

Thermostats of this family may be easily identified by referring to the part number located on the carton and on the back and side of the device.

These thermostats are used for proportional control of pneumatically activated valves, dampers and similar devices in heating, ventilating and air conditioning systems. See Table-1.

Air Consumption: .008 scim (.0021 mL/s) for sizing air compressor.

Supply in Pressure: See Table-1.

Air Capacity: 16 scim (4.37 mL/s) for sizing air mains.

Air Connection: 5/32 plastic tubing.



Table-1 Models.

Part Number	Description and Action *	Dial Range	Factory Setpoint Setting (F)	Throttling Range	Supply Air Pressure
TK-1001-CS&S	Heating DA	55-85 (°F)	75	Adjustable 2 - 10F°/10 psi 1.1-5.5 C°/69 kPa Factory Set 4F°/10 psi (2.2 C°/69 kPa)	15 or 20 psig (103.4 or 137.9 kPa)
TK-1001-116-CS&S		13-29 (°C)			
TK-1101-CS&S	RA Cooling	55-85 (°F)			
TK-1101-116-CS&S		13-29 (°C)			
TK-1201-CS&S	Heating-Cooling DA - 20 psig (137.9 kPa) RA - 15 psig (103.4 kPa)	55-85 (°F)			15 psig (103.4 kPa)- RA* 20 psig (137.9 kPa)- DA*
TK-1281-CS&S	Heating-Cooling DA - 15 psig (103.4 kPa) RA - 20 psig (137.9 kPa)				
TK-1301-CS&S	Day-Night DA				
TK-1301-116-CS&S	Night - 20 psig (137.9 kPa) Day - 15 psig (103.4 kPa)	13-29 (°C)			15 psig (103.4 kPa)- Day 20 psig (137.9 kPa)- Night
TK-1381-CS&S	Day-Night RA Night - 20 psig (137.9 kPa) Day - 15 psig (103.4 kPa)	55-85 (°F)			

*Direct acting: Increases output pressure on temperature rise. Reverse acting: Decreases output pressure on temperature rise.

Pre-Installation

The thermostats are shipped with mounting screws and three 3/4-inch long copper tubes. Wall fittings must be ordered separately.

Air connections: Two plastic tubes reinforced with a coil spring are coded M & B. The M (Black) designates the supply main and the B (White) designates the controlled branch line.

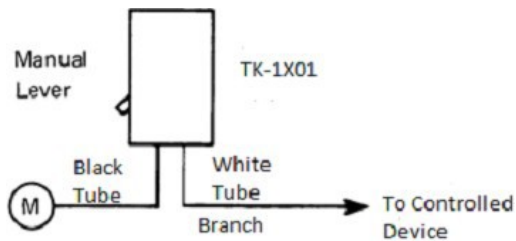

Figure 1

Procedure

To mount a thermostat on an electrical switch box. When installing a thermostat to an electrical switch box (Figure-2) proceed as follows:

1. Attach the mounting plate to the switch box with the two flathead screws provided. Be sure the mounting plate is vertical.
3. Slightly rotate the tubes back and forth, and push firmly on to the fittings (Figure-3).
4. Fasten the thermostat to the mounting plate with the Allen head screws provided and tighten evenly.

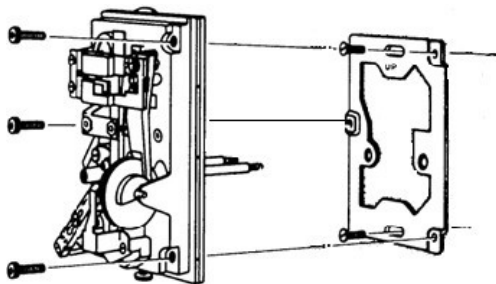

Figure 2

Installation Requirements

Locate the thermostat where it will be exposed to unrestricted circulation of air which represents the average temperature of the controlled space. Do not locate the thermostat near sources of heat or cold, such as lamps, motors, sunlight, or concealed ducts. Maximum safe ambient temperature is 150 °F (65 °C).

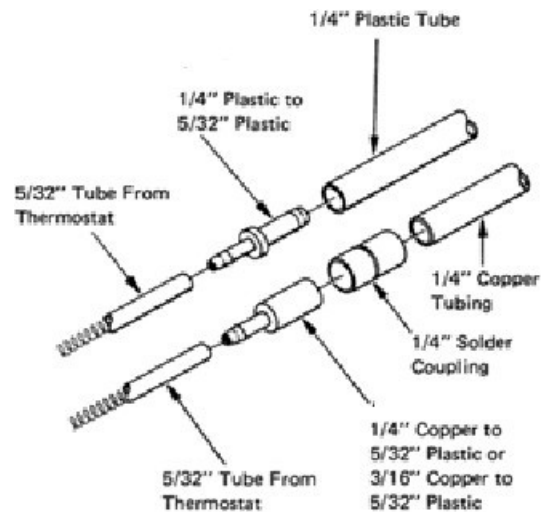

Figure 3

CHECKOUT

After installing the thermostat, verify proper operation as follows:

1. To check the nozzle and/or restriction, turn the setpoint dial to 85°F (30 °C). If the thermostat is direct acting, the output pressure will drop. If the thermostat is reverse acting, the output pressure will rise. Turn the setpoint dial to 55 °F (12 °C). If the thermostat is direct acting, the output pressure should rise. If the thermostat is reverse acting, the output pressure will drop.

(Note: The amount of the rise or drop in the output pressure may vary depending on the ambient temperature in the test area. If output pressure is always 0, the restriction may be plugged. If output is always equal to supply or unable to decrease below 3 psig (20.7 kPa), the nozzle may be plugged.)

2. To check for active thermal element, adjust the setpoint knob to obtain approximately 8 psig (55.1 kPa) branch output. Slightly warm the element with your hand or breath. A direct acting thermostat will increase output pressure. A reverse acting thermostat will decrease output pressure. If the thermostat fails to function properly, refer to REPAIR.

RUN/ADJUST

Throttling Range: The throttling range is factory set at 4F° per 10 psi (2.2 C°/ 69 kPa) control pressure change. It should be set at the lowest value which will allow the thermostat to control the system without cycling under normal load conditions. The most satisfactory setting will vary with the type of system being controlled.

If the throttling range of the thermostat as shipped is not satisfactory, proceed as follows:

1. Measure temperature at sensing element. This should be stable temperature.
2. Rotate setpoint dial to this temperature.
3. With 15 psig (103.4 kPa) supplied to thermostat, adjust calibration screw until 3 psig (20.7 kPa) is read on branch test gauge.
4. Rotate the setpoint dial in a direction which raises the output until 13 psig (89.6 kPa) is read on the branch gauge.
5. The difference between the setpoint dial readings in Step 2 and 4 is the throttling range of the thermostat.
6. If the throttling range in Step 5 is not that desired, move the throttling range slider (Figure-4) in the appropriate direction and repeat Steps 2 through 5 until the desired throttling range is obtained.

The calibration of the thermostat should be checked after the throttling range has been changed.

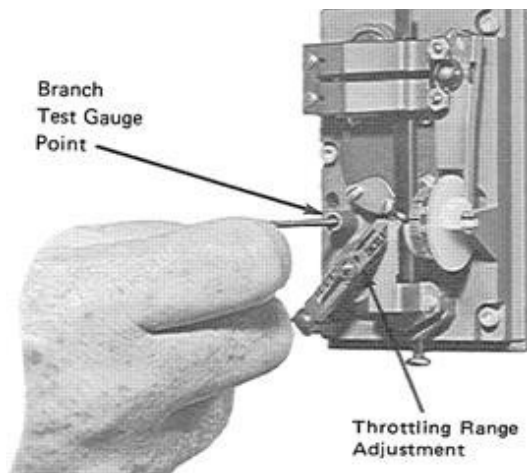

Figure 4

Calibration

As a nominal calibration, the branch line control pressure should be 8 psig (55.1 kPa) when the setpoint is equal to the room temperature indicated by an accurate thermometer. On some applications, a value other than 8 psig (55.1 kPa) will be required to get the desired control results. In this case, change the 8 psig (55.1 kPa) designation used in the calibration procedure.

Caution: *The thermal element of the room thermostat is very sensitive to temperature change. Do not affect its temperature by touching the bimetal or breathing on the thermostat. When calibrating the instrument, observe the room temperature frequently and reset and setpoint dial if required.*

1. Remove the thermostat cover by loosening the cover screw.
2. Using a 5/64-inch Allen wrench, unscrew (counterclockwise rotation) the test point screw one full turn (Figure-4).
3. Attach the test gauge rubber seal to the boss, as shown. Using a rotary motion, push the gauge on as far as it will go (1/4-inch minimum). See Figure-5. The tubing will support the test gauge in a position where it will be easily read. The supply pressure to the thermostat should be 15 psig (103.4 kPa).
4. Adjust the setpoint dial to the room temperature as indicated on the test thermometer.
5. With a 0.48-inch six spline wrench, turn the calibration screw (Figure-6) clockwise if the controlled pressure is above 8 psig (55.1 kPa) and counterclockwise if it below 8 psig (55.1 kPa). Adjust the screw until the controlled pressure is 8 ± 1 psi (55.1 ± 1 kPa).
6. Remove the test gauge.
7. Turn the test point screw clockwise to tighten.
8. Replace cover.

The TK-1001-CS&S, and TK-1101-CS&S thermostats are now calibrated. *Note:* The hex nuts on the calibration screws are tension devices only. They should not be loosened to make an adjustment.

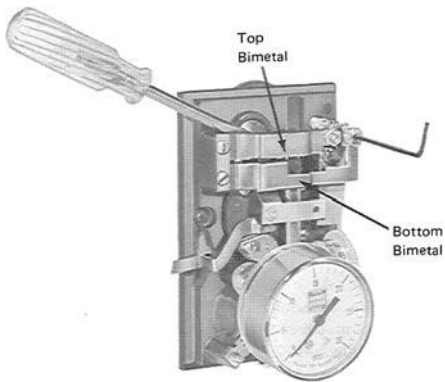

Figure 5

To calibrate TK-1201-CS&S or TK-1301-CS&S proceed as follows using a small screwdriver.

1. Insert the blade of the screwdriver between the switchover plunger and the switchover lever shown in Figure-5. The top bimetal should be approximately 1/32-inch off the lever and the bottom bimetal should be in contact with the lever.
2. With a .048-inch six spline wrench, turn the calibration screw clockwise if the controlled pressure is above 8 psig (55.1 kPa) and counterclockwise if the controlled pressure is below 8 psig (55.1 kPa). Adjust the screw until the pressure is 8 psi \pm 1 psi (55.1 kPa \pm 7 kPa).
3. Manually switch the thermostat several times by removing and reinserting the screwdriver and observing the branch line pressure. If it varies beyond the limits, repeat the calibration.
4. Remove the test gauge.
5. Turn the test point screw clockwise to tighten.
6. Replace cover.

MAINTENANCE

The pneumatic thermostat requires no routine maintenance.

REPAIR

Field repair of pneumatic thermostats is not recommended. However, if the thermostat output pressure is 0 and it cannot be corrected by calibration, the restriction should be checked. Hold the restriction plate up to the light and check the .0075 hole. If the hole is blocked, the restriction plate must be replaced. If the hole is not blocked, then the thermostat should be replaced.

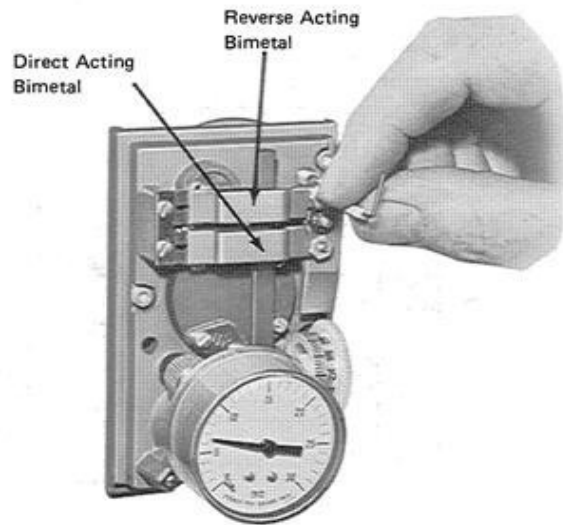

Figure 6

These products are proudly manufactured by Crandall Stats and Sensors, Inc. in Machesney Park, Illinois, USA.