

FULL PORT • THREAD ENDS

Features

- Forged Brass Body
- Stainless Steel Ball
- BlowOut Proof Stem Design
- PTFE Seats
- Handle With Vinyl Grip
- For Gas and Non Potable Water Use

Specifications & Approvals

- Ends Conform to ANSI B1.20.1 / ASME B16.22
- Conforms to NSF/ANSI-61, NSF/ANSI-372, IGC-157
- UL Listed 842,125 125 psig
- FM Certified FM1140 600 psig 1/4" - 2" IPS, 1/2" - 2" SWT
- CSA Certified 1/2 psig / 5 psig / 125 psig 1/4" - 4"
- 600 psi WOG 150 psi WSP
- Temperature Range: -20°F to 300°F
- ISO:9001 Approved Manufacturer

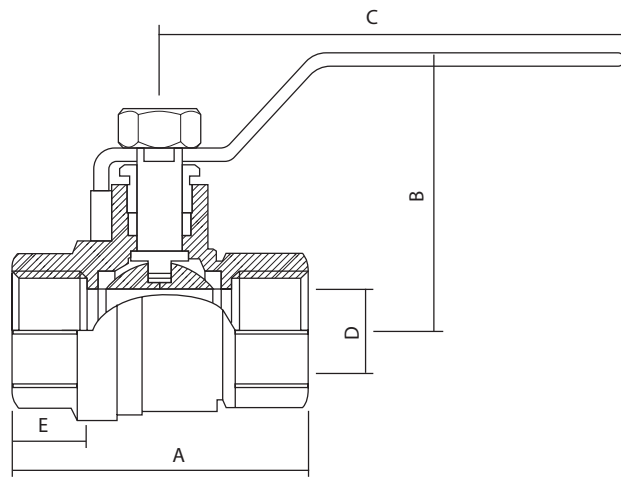

Dimensions

Part#	Size	A	B	C	D	E
300T012	1/2"	2.047	1.921	3.543	0.583	0.520
300T034	3/4"	2.362	2.087	3.780	0.748	0.563
300T001	1"	2.756	2.559	4.528	0.945	0.630
300T114	1-1/4"	3.307	2.953	4.528	1.260	0.709
300T112	1-1/2"	3.661	3.346	5.512	1.575	0.717
300T002	2"	4.181	3.681	5.512	1.969	0.748
300T212	2-1/2"	5.362	4.764	8.661	2.520	1.024
300T003	3"	6.039	5.079	8.661	2.953	1.102
300T004	4"	7.386	5.866	9.606	3.898	1.220

Material Specifications

Part Name	Material
Body	Brass
End Cap	Brass
Ball Seat	PTFE
Ball	Brass
Stem	Brass
Stem Packing	PTFE
Packing Nut	Brass
Lever Handle	Chrome Plating Steel
Stem Nut	Nickel Plating Steel