

FIP X HOSE • LEAD FREE

Features

- Cast Brass Body
- Lead Free
- 3/4 MHT Outlet

Specifications & Approvals

Temperature Rating is 180°F
 Pressure rating is 125 PSI WWP NON SHOCK
 Conforms to ASME A112.18.5/CSA B125.1
 Complies with NSF/ANSI 372-2011

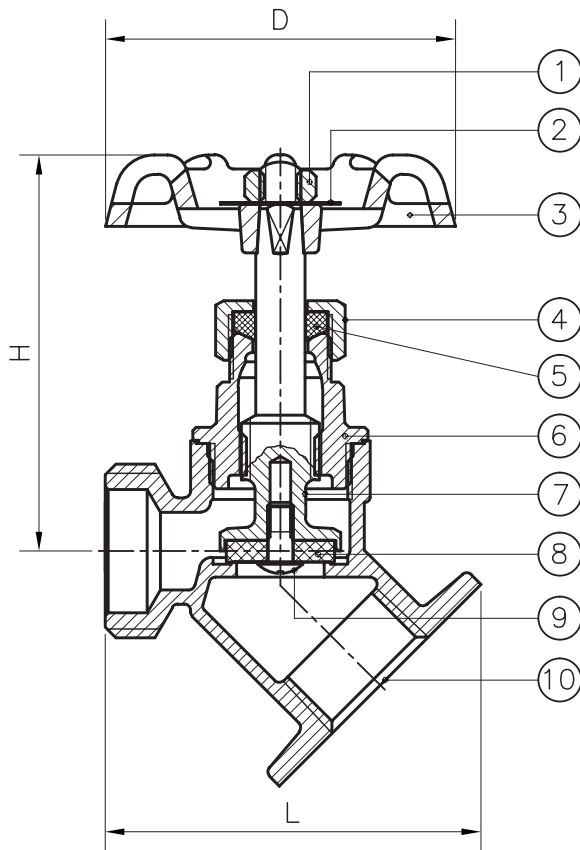

Dimensions

Part#	Size	D	H	L
4712-NL	1/2"	53	61	57
4734-NL	3/4"	53	61	61

Material Specifications

Part Name	Material
1. Wheel Nut	Hot Rolled SAE 1010R
2. Name Plate	Aluminum A1100
3. Handwheel	Cast Iron JIS ZZ2202
4. Packing Nut	Brass Rod C37700
5. Gland Packing	Graphite LK 33 NAFG
6. Bonnet	Cast Brass C46400 MOD
7. Stem	Cast Brass C46400 MOD
8. Seat Packing	Rubber SN-819F
9. Seat Screw	Forged Brass C26000
10. Body	Cast Brass C46400 MOD