

**ENCLOSURES**

**MH1200 Series**

Metal Housing, NEMA 1, 8.3"H x 7.7"W x 3.9"D

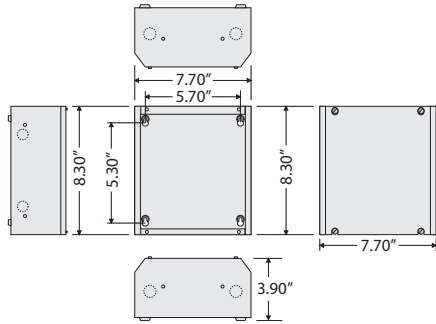

MH1200 SERIES ASSEMBLIES		
Model #	Enclosure	Plastic Snap Track
MH1200	MH1200	
MH1210	MH1200	MT4-8 (4.00"W)
MH1220	MH1200	MT212-8 (2.75"W)



**SPECIFICATIONS**

- Construction:** 18 Gauge Steel
- Cover Type:** Screw Down Cover
- Approvals:** UL Listed, C-UL, CE, RoHS
- Origin:** Made of US and non-US parts

- Notes:**
- Consult factory for custom colors for large orders.