



# M9102-AGA-2S and M9104-xGA-2S Series Electric Non-Spring Return Actuators

## Installation Instructions

Part No. 34-636-1220, Rev. L  
Issued September 2017

### Applications

The M9102 and M9104 Series Actuators are direct-mount, non-spring return electric actuators that operate on AC 24 V power and use plenum cables for field wiring. Employing a synchronous motor, these actuators provide floating control (AGA), floating control with automatic shutoff (IGA), and proportional control with selectable 0-10 or 2-10 VDC (GGA).

All models are compact in size and are easily installed on Variable Air Volume (VAV) boxes, Variable Air Volume and Temperature (VVT) two-position zone applications, or small to medium-sized dampers with a round shaft up to 1/2 in. (13 mm) in diameter, or a 3/8 in. (10 mm) square shaft.

The M9102 Series Electric Non-Spring Return Actuators provide a running torque of 18 lb·in (2 N·m), and the nominal travel time is 30 seconds at 60 Hz (36 seconds at 50 Hz) for 90° of rotation.

The M9104 Series Electric Non-Spring Return Actuators provide a running torque of 35 lb·in (4 N·m), and the nominal travel time is 60 seconds at 60 Hz (72 seconds at 50 Hz) for 90° of rotation.

**IMPORTANT:** Use this M9102 or M9104 Series Electric Non-Spring Return Actuator only to control equipment under normal operating conditions. Where failure or malfunction of the electric actuator could lead to personal injury or property damage to the controlled equipment or other property, additional precautions must be designed into the control system. Incorporate and maintain other devices, such as supervisory or alarm systems or safety or limit controls, intended to warn of or protect against failure or malfunction of the electric actuator.

**IMPORTANT:** Utiliser ce M9102 or M9104 Series Electric Non-Spring Return Actuator uniquement pour commander des équipements dans des conditions normales de fonctionnement. Lorsqu'une défaillance ou un dysfonctionnement du electric actuator risque de provoquer des blessures ou d'endommager l'équipement contrôlé ou un autre équipement, la conception du système de contrôle doit intégrer des dispositifs de protection supplémentaires. Veiller dans ce cas à intégrer de façon permanente d'autres dispositifs, tels que des systèmes de supervision ou d'alarme, ou des dispositifs de sécurité ou de limitation, ayant une fonction d'avertissement ou de protection en cas de défaillance ou de dysfonctionnement du electric actuator.

## Installation

The M9102 and M9104 Series Electric Non-Spring Return Actuators mount directly to the surface in any convenient orientation using a single No. 10 self-drilling sheet metal screw (included with the actuator). No additional linkages or couplers are required. Electrical connections on the actuator are clearly labeled to simplify installation.

**IMPORTANT:** Before specifying M9102 or M9104 Series Electric Non-Spring Return Actuators for plenum applications, verify acceptance of exposed plastic materials in plenum areas with the local building authority. Building codes for plenum requirements vary by location. Some local building authorities accept compliance to UL 1995, Heating and Cooling Equipment, while others use different acceptance criteria.

**IMPORTANT:** Do not install or use this M9102 or M9104 Series Electric Non-Spring Return Actuator in or near environments where corrosive substances or vapors could be present. Exposure of the electric actuator to corrosive environments may damage the internal components of the device, and will void the warranty.

### Parts Included

- one electric non-spring return actuator with an integrated 48 in. (1.2 m) long cable
- one No. 10 self-drilling sheet metal screw

### Special Tools Needed

- 5/16 in. (8 mm) square socket
- #2 Phillips screwdriver
- 3/8 in. (10 mm) 12-point socket
- drill with a 5/16 in. (8 mm) hex nut driver
- digital voltmeter

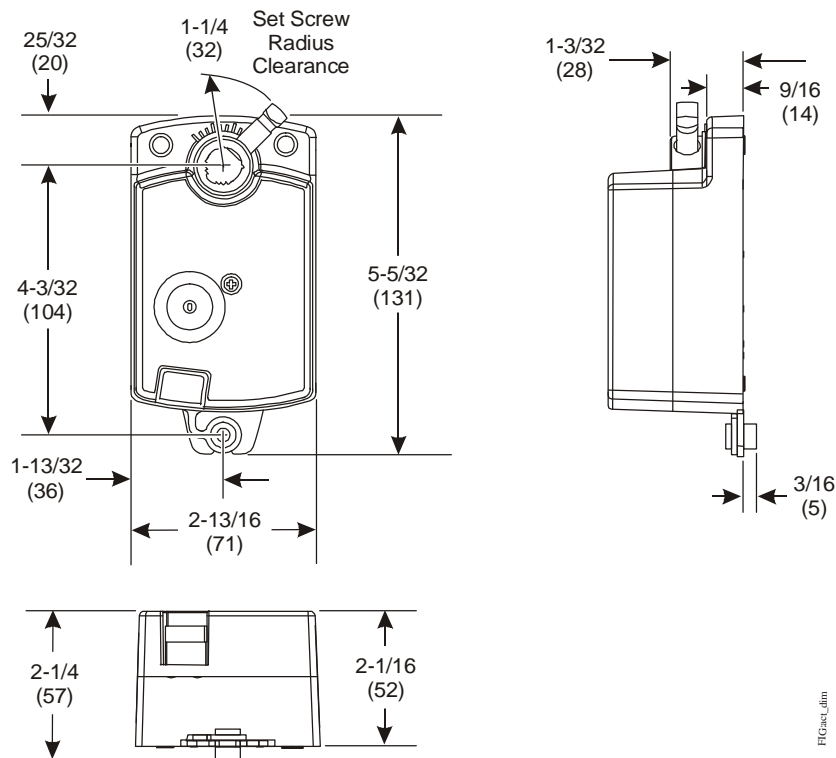

Figure 1: M9102 and M9104 Series Electric Non-Spring Return Actuator Dimensions, in. (mm)

## Accessories

**Table 1: Accessories (Order Separately)**

Code Number	Description
<b>DMPR-KC003</b>	7 in. (178 mm) Blade Pin Extension without Bracket for Johnson Controls® Direct-Mount Damper Applications
<b>DMPR-KR003</b>	Sleeve Pin Kit for Johnson Controls Round Dampers with a 5/16 in. (8 mm) Diameter Shaft
<b>M9104-100</b>	Connector for 3/8 in. (10 mm) flexible metal conduit

## Mounting

To mount the actuator to a damper:

1. Check that the damper blade is visually accessible, or its position is permanently marked on the end of the damper shaft, as illustrated in Figure 2.

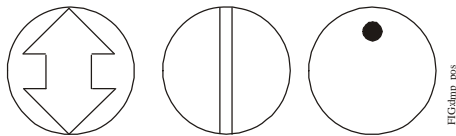

**Figure 2: Damper Position Icons**

2. Grasp the damper shaft firmly with pliers and rotate the damper fully closed, as illustrated in Figure 3.

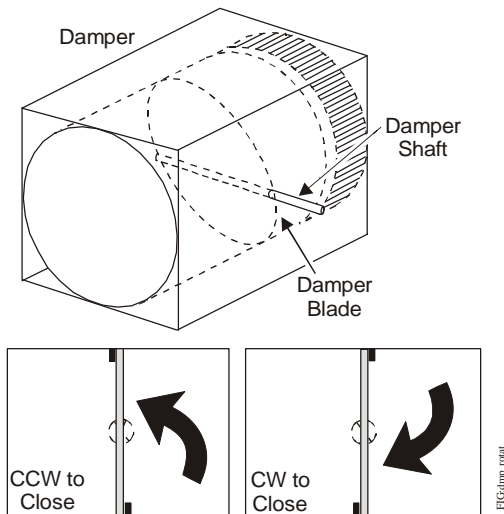

**Figure 3: Damper Rotation**

3. Make a note of the rotation range and direction, either clockwise (CW) or counterclockwise (CCW), required to close the damper.

4. Press and hold the gear release lever, and rotate the actuator coupler to the fully closed position, as determined in Step 2.
5. Position the actuator onto the damper shaft so that the damper shaft protrudes through the actuator coupler, as illustrated in Figure 4.

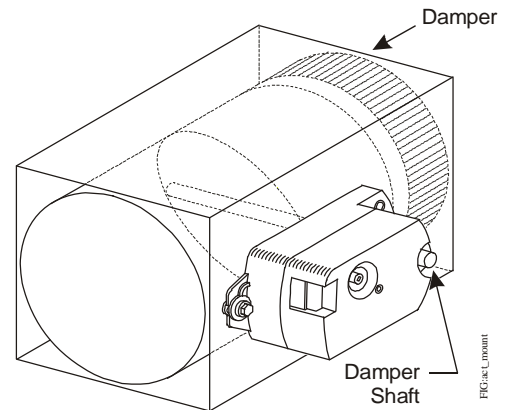

**Figure 4: Mounting the Actuator onto the Damper Shaft**

6. Be certain that the actuator is in the desired mounting position parallel to the mounting surface, as illustrated in Figure 5.

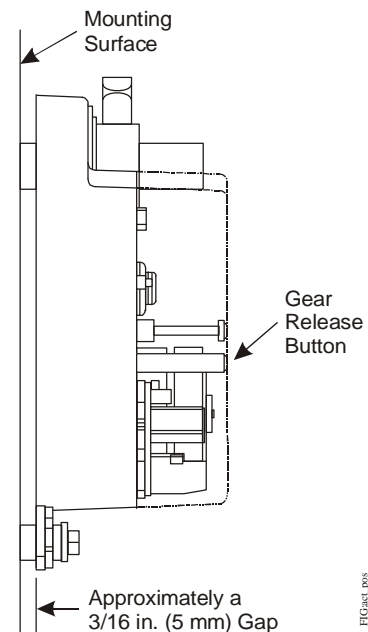

**Figure 5: Positioning the Actuator**

7. Hold the actuator in place on the damper shaft, and insert the No. 10 self-drilling sheet metal screw through the shoulder washer, as illustrated in Figure 6.

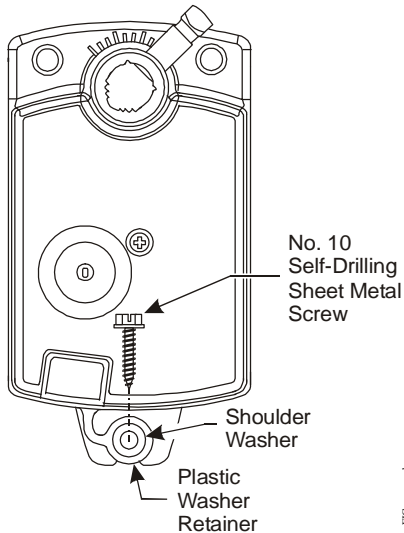

**Figure 6: Inserting the Screw into the Shoulder Washer**

8. Place a 5/16 in. (8 mm) socket on the screw and use a drill and extension to drill the screw into the mounting surface. Drive the screw until it is tight against the washer.

**IMPORTANT:** Do not overtighten the mounting screw. Overtightening may strip the threads.

9. Tighten the square coupler bolt to the shaft using an 8 mm (5/16 in.) wrench or 10 mm (3/8 in.) 12-point socket. Tighten to 10.7 to 11.8 N·m (95 to 105 lb-in).

## Wiring

### **M9102-AGA-2S, M9104-AGA-2S**

The M9102 and M9104 Series Electric Non-Spring Return Actuators require an AC 24 V input signal and are compatible with a variety of VAV and VVT controllers. These electric actuators include an integrated 48 in. (1.2 m) long cable. See Figure 7 for proper wiring.

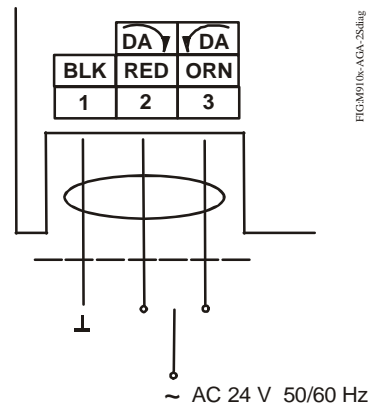
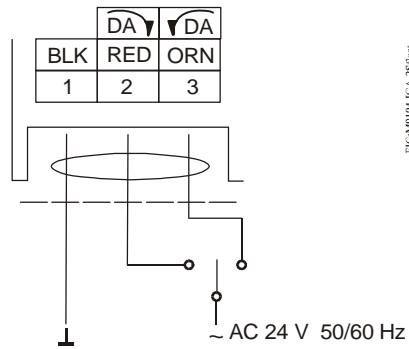

**Figure 7: M9102-AGA-2S and M9104-AGA-2S Control Wiring Diagram**

**Note:** When using an AGA model, you must use a VAV or VVT controller and/or software that provides a timeout function at the end of rotation (stall) to avoid excessive wear or drive time on the actuator motor.

### M9104-IGA-2S

The M9104-IGA Series Electric Non-Spring Return valve actuators require an AC 24 V input signal and work with a variety of controllers. These electric actuators include an integrated 48 in. (1.2 m) long cable and have an auto-shutoff feature to prevent excessive wear or drive time on the motor. See Figure 8 and Figure 9 for proper wiring options.



**Figure 8: M9104-IGA-2S Control Wiring Diagram - Floating**

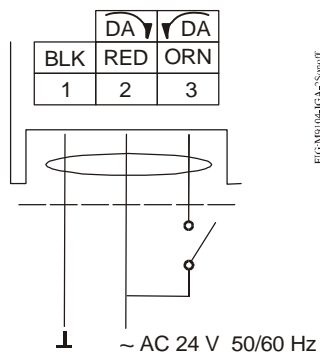

**Figure 9: M9104-IGA-2S Control Wiring Diagram - On/Off**

## M9104-GGA-2S

The M9104-GGA Series Electric Non-Spring Return valve actuators require AC 24 V power and a DC 0(2) to 10 V or 0(4) to 20 mA controller input signal. These electric actuators include an integrated 48 in. (1.2 m) long cable. See Figure 10 for proper wiring.

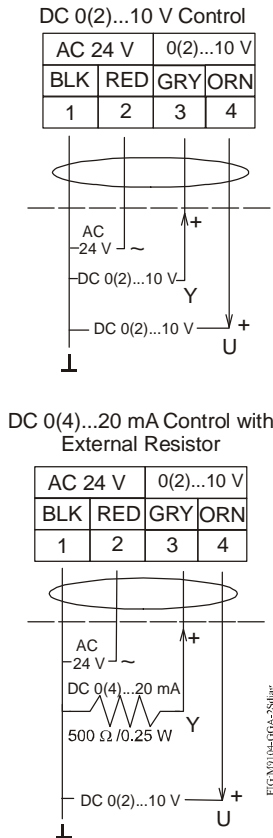

Figure 10: M9104-GGA-2S Control Wiring Diagram

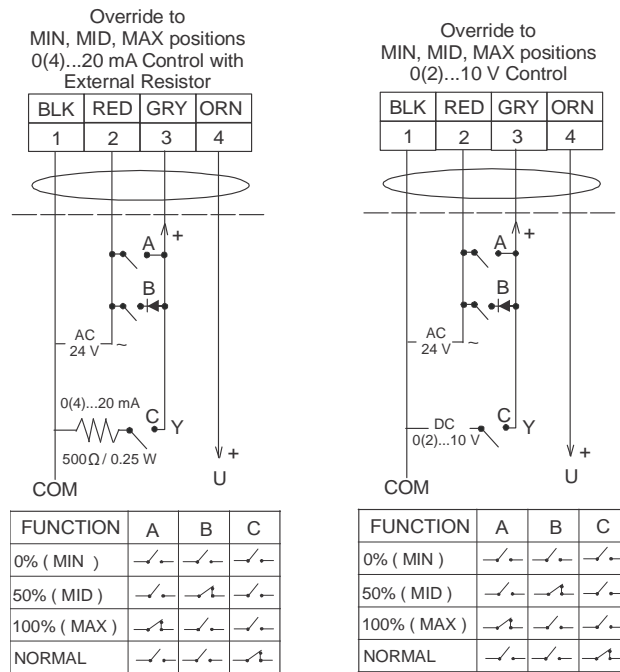
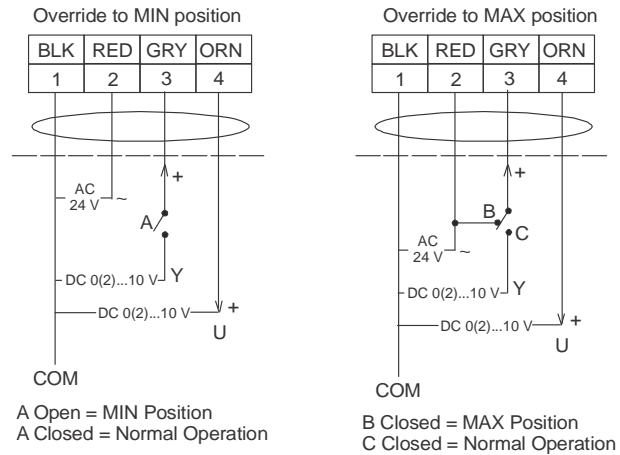
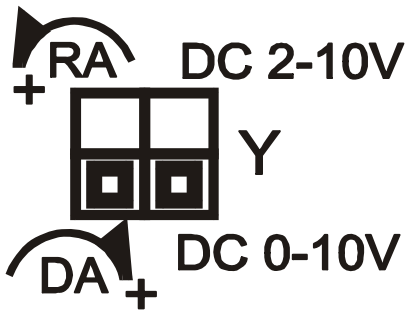

Figure 11: M9104-GGA Control Wiring Diagram (Overrides)

M9104-GGA actuators are factory set for Direct Acting (DA) mode and for a DC 0 to 10 V input control signal. In DA mode, a minimum control signal drives the actuator to the full Counterclockwise (CCW) position, and a maximum control signal drives the actuator to the full Clockwise (CW) position.

For Reverse Acting (RA) operation, a minimum control signal drives the actuator to the full CW position and a maximum signal drives the actuator to the full CCW position.



**Figure 13: M9104-GGA Factory Switch Setting**

To change the factory settings (DA, 0-10 V), remove the actuator cover and adjust the switches on the circuit board as shown in Figure 13.

		Rotation Range							
		90°	75°	60°	45°	30°	15°	0°	
		0°	15°	30°	45°	60°	75°	90°	
Direct Acting	0-10V Feedback	10.0V	8.3V	6.7V	5.0V	3.3V	1.7V	0.0V	
	2-10V Feedback	10.0V	8.7V	7.3V	6.0V	4.7V	3.3V	2.0V	
Reverse Acting	0-10V Feedback	0.0V	1.7V	3.3V	5.0V	6.7V	8.3V	10.0V	
	2-10V Feedback	2.0V	3.3V	4.7V	6.0V	7.3V	8.7V	10.0V	

**Figure 12: Feedback Signal Relative to the Rotation Range**



**CAUTION: Risk of Electric Shock.** Disconnect the power supply before making electrical connections to avoid electric shock.

**MISE EN GARDE : Risque de décharge électrique.** Débrancher l'alimentation avant de réaliser tout raccordement électrique afin d'éviter tout risque de décharge électrique.



**CAUTION: Risk of Property Damage.** Do not apply power to the system before checking all wiring connections. Short circuited or improperly connected wires may result in permanent damage to the equipment.

**MISE EN GARDE : Risque de dégâts matériels.** Ne pas mettre le système sous tension avant d'avoir vérifié tous les raccords de câblage. Des fils formant un court-circuit ou connectés de façon incorrecte risquent d'endommager irrémédiablement l'équipement.

**IMPORTANT:** Make all wiring connections in accordance with local, national, and regional regulations. Do not exceed the electrical ratings of the M9102 or M9104 Series Electric Non-Spring Return Valve Actuator.

## Setup and Adjustments

### Commissioning

After wiring is completed, apply power to the VAV or VVT controller and provide input signals to the actuator to drive it at least one complete cycle open and closed.

### Troubleshooting

If the M9102 or M9104 Series Electric Non-Spring Return Actuator is not responding or working properly:

- verify that the actuator assembly is properly secured to the duct
- check that all electrical connections are complete and that power is applied
- verify that the damper fully opens and closes, using the gear release button on the actuator
- check that the actuator stroke is set for the desired application

### Repair Information

If the M9102 or M9104 Series Electric Non-Spring Return Actuator fails to operate within its specifications, replace the unit. For a replacement electric actuator, contact the nearest Johnson Controls representative.

## Technical Specifications

### M9102-AGA-2S and M9104-xGA-2S Series Electric Non-Spring Return Actuators

<b>Power Requirements</b>	M910x-AGA-2S	AC 24 V +25%/-20% at 50/60 Hz, 2.1 VA, Class 2, Safety Extra-Low Voltage (SELV)
	M9104-IGA-2S	AC 24 V +25%/-20% at 50/60 Hz, 3.0 VA, Class 2, SELV
	M9104-GGA-2S	AC 24 V +25%/-20% at 50/60 Hz, 2.9 VA, Class 2, SELV (Class III)
<b>Control Type</b>	M910x-AGA-2S	Floating Control without Timeout
	M9104-IGA-2S	Floating or On/Off Control with Timeout
	M9104-GGA-2S	Proportional Control
<b>Input Signal</b>	M9102-AGA-2S	AC 24 V +25%/-20% at 50/60 Hz, Class 2, SELV
	M9104-AGA-2S	AC 24 V +25%/-20% at 50/60 Hz, Class 2, SELV without Timeout
	M9104-IGA-2S	AC 24 V +25%/-20% at 50/60 Hz, Class 2, SELV with Timeout
	M9104-GGA-2S	DC 0 (2) to 10 V or 0 (4) to 20 mA with field furnished 500 ohm resistor
<b>Feedback Signal</b>	M9104-GGA-2S	0 to 10 VDC or 2 to 10 VDC for 90° (10 VDC at 1 mA) Corresponds to input signal span selection
<b>Motor Input Impedance</b>		200 ohms Nominal
<b>Running Torque</b>	M9102 Series	18 lb-in (2 N·m)
	M9104 Series	35 lb-in (4 N·m)
<b>Travel Time</b>	M9102 Series	30 seconds at 60 Hz (36 seconds at 50 Hz) for 90° of rotation
	M9104 Series	60 seconds at 60 Hz (72 seconds at 50 Hz) for 90° of rotation
<b>Rotation Range</b>		93° ±3°, CW or CCW
<b>Cycles</b>		100,000 Full Stroke Cycles; 2,500,000 Repositions at Rated Running Torque
<b>Audible Noise Rating</b>		35 dBA Nominal at 39-13/32 in. (1 m)
<b>Electrical Connections</b>		48 in. (1.2 m) UL 444 Type CMP Plenum Rated Cable with 19 AWG (0.75 mm <sup>2</sup> ) conductors and .25 in. (6 mm) ferrule ends
<b>Mechanical Connections</b>		Up to 1/2 in. (13 mm) Diameter Round Damper Shaft or 3/8 in. (10 mm) Square Damper Shaft
<b>Enclosure</b>		NEMA 2, IP42
<b>Ambient Conditions</b>	Operating	-4 to 140°F (-20 to 60°C); 90% RH Maximum, Noncondensing
	Storage	-20 to 150°F (-29 to 66°C); 90 RH Maximum, Noncondensing
<b>Compliance</b>  	<b>United States</b>	UL Listed, CCN XAPX, File 27734 Plenum rated, UL2043, suitable for use in other environmental spaces (plenums) in accordance with section 300.22.(c) of the National Electrical Code
	<b>Canada</b>	cUL Listed, CCN XAPX7, File 27734 Plenum Rated Per CSA 22.2 No. 236/UL 1995, Heating and Cooling Equipment
	<b>Europe</b>	Johnson Controls, Inc. declares that this product is in compliance with the essential requirements and other relevant provisions of the EMC Directive and the Low Voltage Directive.
	<b>Australia and New Zealand</b>	RCM Mark, Australia/NZ Emissions Compliant
<b>Shipping Weight</b>		1.0 lb (0.5 kg)

The performance specifications are nominal and conform to acceptable industry standards. For application at conditions beyond these specifications, consult the local Johnson Controls office. Johnson Controls, Inc. shall not be liable for damages resulting from misapplication or misuse of its products.



**European Single Point of Contact:**

JOHNSON CONTROLS  
WESTENDHOF 3  
45143 ESSEN  
GERMANY

**NA/SA Single Point of Contact:**

JOHNSON CONTROLS  
507 E MICHIGAN ST  
MILWAUKEE WI 53202  
USA

**APAC Single Point of Contact:**

JOHNSON CONTROLS  
C/O CONTROLS PRODUCT  
MANAGEMENT  
NO. 22 BLOCK D NEW DISTRICT  
WUXI JIANGSU PROVINCE 214142  
CHINA



*Metasys® and Johnson Controls® are registered trademarks of Johnson Controls.  
All other marks herein are the marks of their respective owners. © 2017 Johnson Controls.*