

# Carbon Steel Ball Valve



**5 Piece • Full Port • Double Union End • Socket Weld •  
3000 WOG • Stainless Steel Ball and Stem**



**S-CS-2002N-SS-DUE**

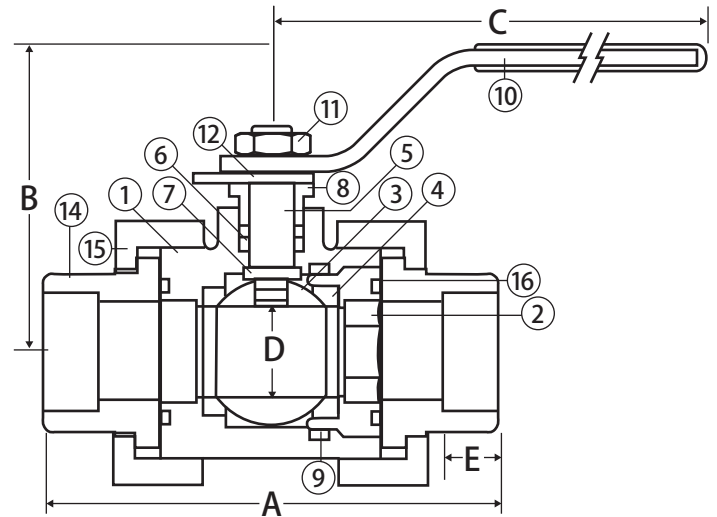

## Material Specifications

No.	Part	Materials
1	Body	WCB Carbon Steel
2	Body Insert	WCB Carbon Steel
3	Ball	CF8M Stainless Steel
4	Seat (2) <sup>†</sup>	Hostaflon® TFM 1600
5	Stem	316 Stainless Steel
6	Packing (2) <sup>†</sup>	RPTFE
7	Stem Seal <sup>†</sup>	Hostaflon® TFM 1600
8	Packing Gland	304 Stainless Steel
9	Body Seal (1) <sup>†</sup>	Hostaflon® TFM 1600
10	Handle	304 Stainless Steel
11	Handle Nut	304 Stainless Steel
12	Stop Plate	304 Stainless Steel
13	Lock Pin*	304 Stainless Steel
14	Tail Piece (2)	WCB Carbon Steel
15	Union Nut (2)	WCB Carbon Steel
16	Union Seal (2) <sup>†</sup>	Hostaflon® TFM 1600

\*Not shown in drawing

<sup>†</sup>Included in repair kit

## Features

- Solid ball construction
- 5 piece construction
- Mounting pad
- Reversible handle
- Adjustable stem packing with blow out proof stem
- 29 in-Hg vacuum rating
- 100% leak tested
- Wetted surfaces contain less than .25% lead content
- Repair kits available
- Locking handle available

## Approvals

- API-598
- MSS SP-110
- NACE Certified
- ANSI B16.11

## Valve Seat Rating 3000 WOG - 150 WSP

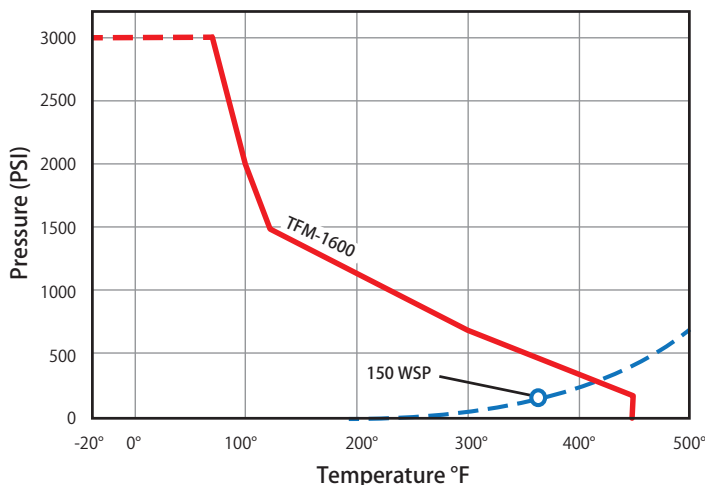

## Dimensions

Part No.	Size	A	B	C	D	E	Torque
101-991	1/4"	3.58	2.40	4.17	0.44	0.41	35
101-992	3/8"	3.58	2.40	4.17	0.44	0.41	35
101-993	1/2"	3.58	2.40	4.17	0.62	0.44	65
101-994	3/4"	3.74	2.79	6.97	0.81	0.56	100
101-995	1"	4.29	2.96	6.97	1.00	0.72	120
101-996	1-1/4"	4.61	3.38	9.84	1.25	0.72	210
101-997	1-1/2"	5.24	3.67	9.84	1.50	0.72	300
101-998	2"	5.71	4.52	12.24	1.97	0.84	400



**WARNING:** This product can expose you to chemicals including diisononyl phthalate (DINP), which is known to the State of California to cause cancer, and diisononyl phthalate (DINP), which is known to the State of California to cause birth defects or other reproductive harm. For more information go to [www.P65Warnings.ca.gov](http://www.P65Warnings.ca.gov).

