

Lead Free Brass Ball Valve

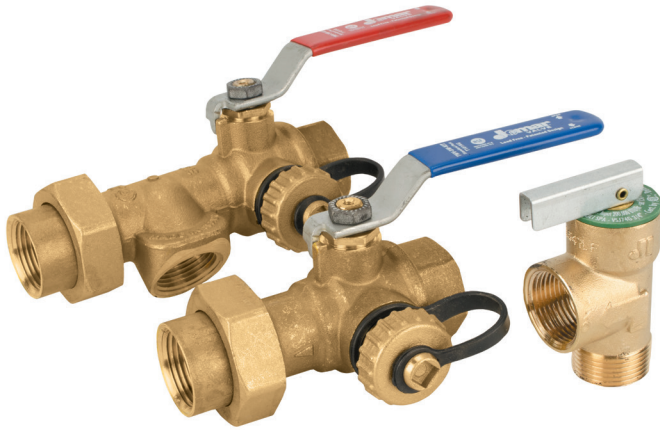

3 Way Ball • Tankless Water Heater Valve Kit • Threaded, Solder, or Press Connections • 600 WOG



TWV-3W-KIT-G

Features

- Unique, T.E.A. Ternary Eco Alloy® Coated 3-way style ball
- 2 Viton® o-rings with Teflon packing and packing nut guarantees no stem leaks
- US Patent No. 7,762,280 B2
- 3/4" 200,000 BTU/hr lead free pressure relief valve included
- 100% leak tested
- 100% Made in Italy
- Leakproof stem - Lifetime Warranty
- Wetted surfaces contain less than .25% lead content

Approvals

- NSF 372
- NSF 61-8
- NSF 61 - Annex G
- ANSI B1.20.1
- ANSI B1.20.7

Valve Seat Rating 600 WOG - 150 WSP

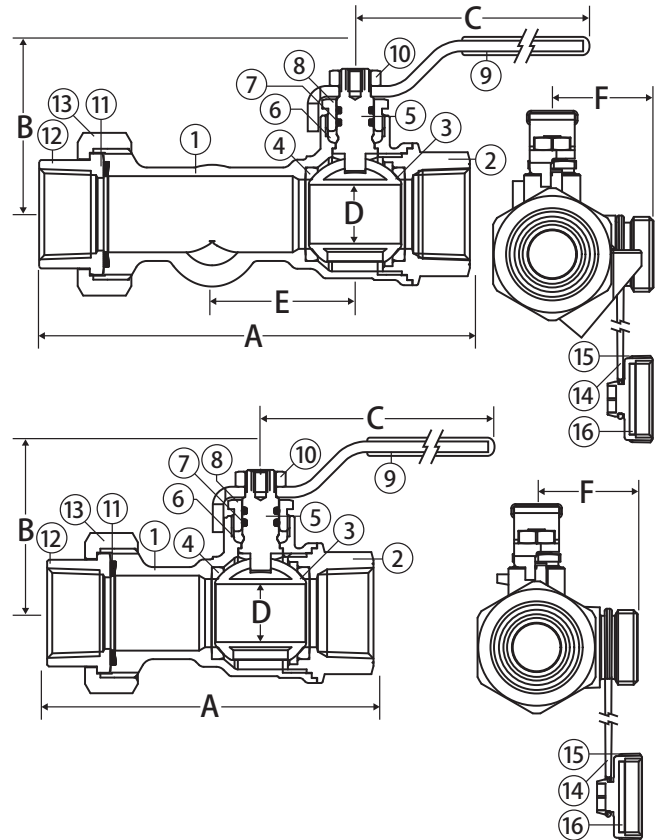
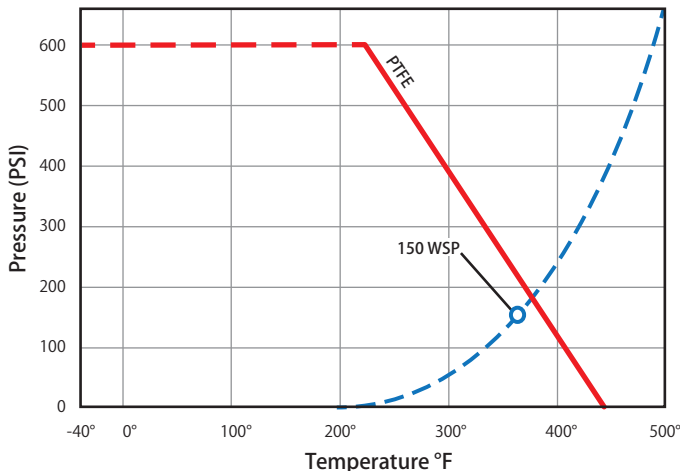

Material Specifications

No.	Part	Materials
1	Body	Lead Free Brass - CW510L
2	End Connection	Lead Free Brass - CW510L
3	Ball	T.E.A. Coated Brass - CW510L
4	Seat (2)	PTFE
5	Stem	Lead Free Brass - CW510L
6	Packing	PTFE
7	Stem O-ring (2)	Viton®
8	Packing Gland	Brass - CW614N
9	Handle	Steel - Geomet® Plated
10	Handle Nut	Steel - Geomet® Plated
11	Union Washer	EPDM
12	Tail Piece	Lead Free Brass - CW510L
13	Union Nut	Brass - CW617N
14	Tether	PVC
15	Cap	Lead Free Brass - CW510L
16	Flat Washer	Buna-N

Dimensions

Part No.	Valve	A	B	C	D	E	F
810-504G Threaded	Hot	5.11	2.00	3.74	0.66	1.65	1.41
	Cold	3.93	2.00	3.74	0.66	-	1.41
810-514G Solder	Hot	5.35	2.00	3.74	0.66	1.65	1.41
	Cold	4.17	2.00	3.74	0.66	-	1.41
810-524G Press	Hot	5.71	2.00	3.74	0.66	1.65	1.41
	Cold	4.53	2.00	3.74	0.66	-	1.41



LEAD FREE