

RECIRCSETTER™

THERMOSTATIC BALANCING VALVE

TECHNICAL BROCHURE

TABLE OF CONTENTS

ABOUT THE RECIRCSETTER™	3
.....	
STANDARD THERMOSTATIC BALANCING: TB-120G & TB-120MG	4
.....	
THERMAL DISINFECTION: TB-130G & TB-130MG	6
.....	
ACTUATED THERMAL DISINFECTION: TB-150G & TB-150MG	8
.....	
PRESETTING OPERATION	11
.....	
INSTALLATION	11
.....	
ACCESSORIES	12
.....	
EXAMPLE CALCULATIONS	13
.....	
DESIGN C_v GUIDE	20

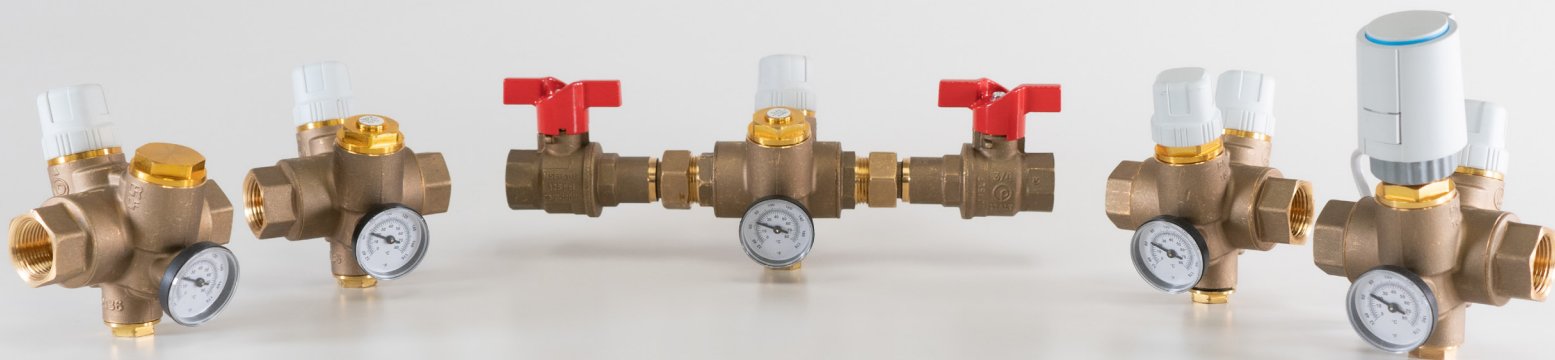

RECIRCSETTER™

THERMOSTATIC BALANCING VALVE

The RecircSetter™ by Jomar Valve is an adjustable thermostatic balancing valve (TBV) for domestic hot water recirculation system applications. This balancing valve utilizes a thermostatic cartridge, which eliminates the need for pressure ports to balance the system and allows the valve to balance based on temperature as opposed to pressure or flow.

The RecircSetter™ is certified to NSF 61 and NSF 372 for potable hot water systems and has an adjustable hand wheel with a temperature range from 95°F to 140°F. It can be equipped with a thermal cartridge for thermal disinfection treatment at a fixed temperature of 160°F, or with an actuated bypass to fully control the thermal disinfection process with a Building Management System (BMS). The RecircSetter™ is available with female NPT connections, a drywell thermometer, and is equipped with a temperature sensor port for remote monitoring (½" NPT plugged).

OPERATING PRINCIPLE

Thermostatic balancing valves solve the balancing challenges of hot water recirculation systems by recirculating the hot water loop based on temperature - rather than traditional methods based on pressure or flow - in order to achieve uniform hot water at each fixture. The RecircSetter™ balances based upon the water temperature of the line: the valve modulates open or "closed" depending on the desired recirculation temperature. The desired recirculation temperature is chosen by the system designer and is field adjustable should the system demand change. It is important to note that the RecircSetter™ is never fully closed: an amount of flow is continuously circulating through the valve even when in its "closed" position.

MATERIAL	
BODY	LEAD FREE BRASS - CW511L
O-RING	EPDM
PRESETTING HAND WHEEL	NYLON 66
PROTECTION HAND WHEEL	ABS
SPRING	AISI 302 STAINLESS STEEL
SHUTTER	PSU

CHARACTERISTICS	
MAX WORKING PRESSURE	232 PSI
MAX DIFFERENTIAL PRESSURE	14.50 PSI
MAX WORKING TEMPERATURE	194°F
TEMPERATURE SETTING RANGE	95°F - 140°F
ACCURACY	+/- 4°F
FACTORY PRESETTING	125°F
THERMAL DISINFECTION TEMPERATURE	160°F
C_{VMAX}	2.10
C_{VMIN}	0.23
$C_{VDISINF}$	1.16 - 1.21
$C_{VDESIGN}$	0.53 - 0.59



TB-120G & TB-120MG

RECIRCSETTER™

STANDARD THERMOSTATIC BALANCING

The typical challenge with domestic hot water balancing is keeping the minimum desired water temperature at all fixtures, even those located farthest from the water heater.

The RecircSetter™ modulates to balance the hot water recirculation branch based on the selected temperature through its thermostatic cartridge.

By selecting the same temperature at every valve, a uniform temperature is ensured in every branch.

Designers can select the design temperature within the

range of 95°F and 140°F (factory setting 125°F) by using the presetting hand wheel. It is best practice to have the same temperature selected for every valve in the system.

The RecircSetter™ TB-120G is available in three configurations: (1) base; (2) base + check valve; (3) base + dual isolation + integrated check valve.

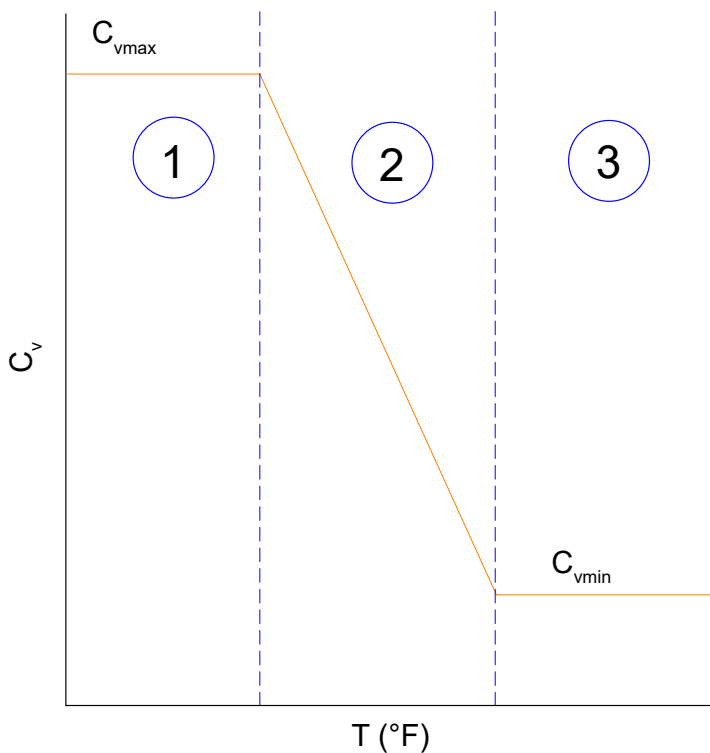

Working Area 1 - Maximum C_{vmax} , $T_{water} \ll T_{desiredrecirc}$

In this temperature range, the valve is completely open and a spring is balancing the thermostatic cartridge

Working Area 2 - Variable C_v , when T_{water} is reaching $T_{desiredrecirc}$

When the water temperature is approaching the selected balancing temperature, the thermostatic cartridge is expanding until it reaches the "closed" position where the minimum flow is met, C_{vmin}

Working Area 3 - C_{vmin} , $T_{water} \geq T_{desiredrecirc}$

When the water temperature is higher than the selected temperature, the thermostatic cartridge is keeping the valve in "closed" position and the minimum flow occurs, C_{vmin}

The TB-120G/MG is not a shut-off valve: an amount of flow, C_{vmin} is continuously circulating through the valve even when in its "closed" position. The TB-120G/MG is not designed with features to incorporate disinfect operations.

TB-120G | base

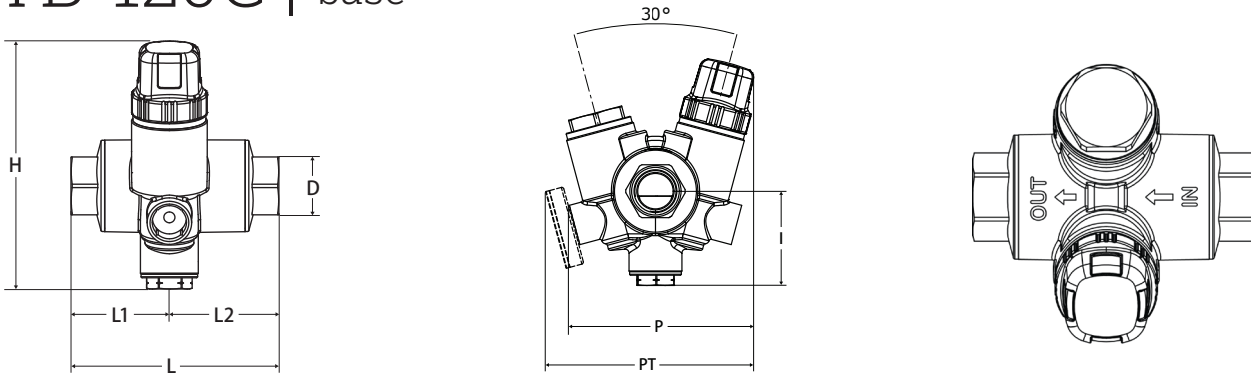

TB-120G	PART NO	D	L	L1	L2	H	I	P	PT
FXF	180-103G-B	1/2"	3.66	1.73	1.93	4.41	1.81	3.58	4.02
FXF	180-104G-B	3/4"	3.9	1.85	2.05	4.41	1.81	3.58	4.02

TB-120G | base + check valve

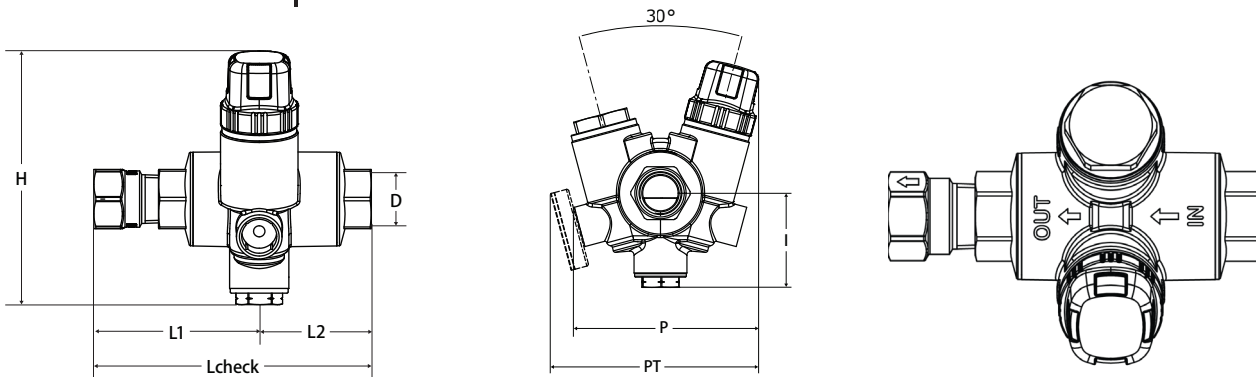

TB-120G	PART NO	D	L _{CHECK}	L1	L2	H	I	P	PT
FXF	180-103G-B-C	1/2"	4.8	2.87	1.93	4.41	1.81	3.58	4.02
FXF	180-104G-B-C	3/4"	5.43	3.39	2.05	4.41	1.81	3.58	4.02

TB-120MG | base + dual isolation + integrated check valve

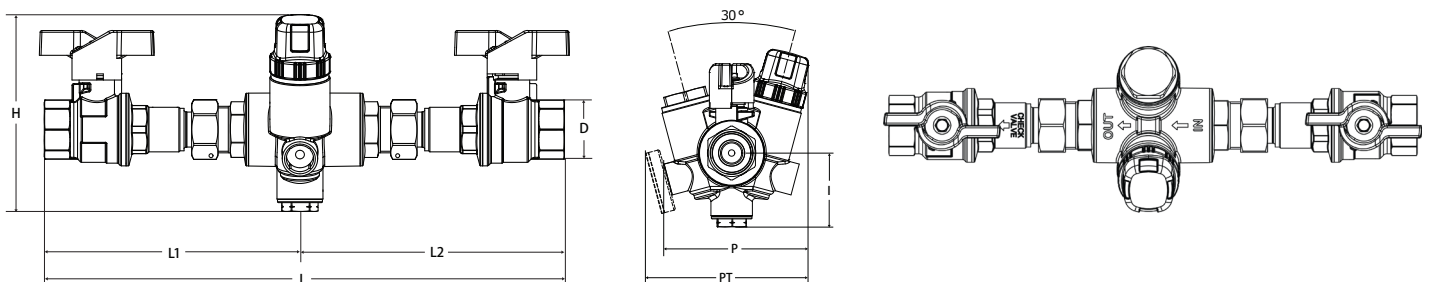

TB-120MG	PART NO	D	L	L1	L2	H	I	P	PT
FXF	180-103MG-B-I	1/2"	11.5	5.75	5.75	4.41	1.81	3.58	4.02
FXF	180-104MG-B-I	3/4"	11.5	5.75	5.75	4.41	1.81	3.58	4.02



TB-130G & TB-130MG

RECIRCSETTER™

THERMAL DISINFECTION

As recommended by health safety standards, disinfection treatments may be required to avoid proliferation of bacteria in a potable water system. A common thermal disinfection procedure occurs by flushing the system with a water temperature above 158°F. This temperature is the point where bacteria is eradicated.

The RecircSetter™ TB-130G/MG model is equipped with a thermal disinfection cartridge. As the line temperature approaches 150°F, the valve will modulate open to allow increased flow, and will then begin to “close” as the line

temperature approaches 160°F. The disinfection temperature cannot be modified by the end user.

The RecircSetter™ TB-130G is available in three configurations: (1) disinfect; (2) disinfect + check valve; (3) disinfect + dual isolation + integrated check valve.

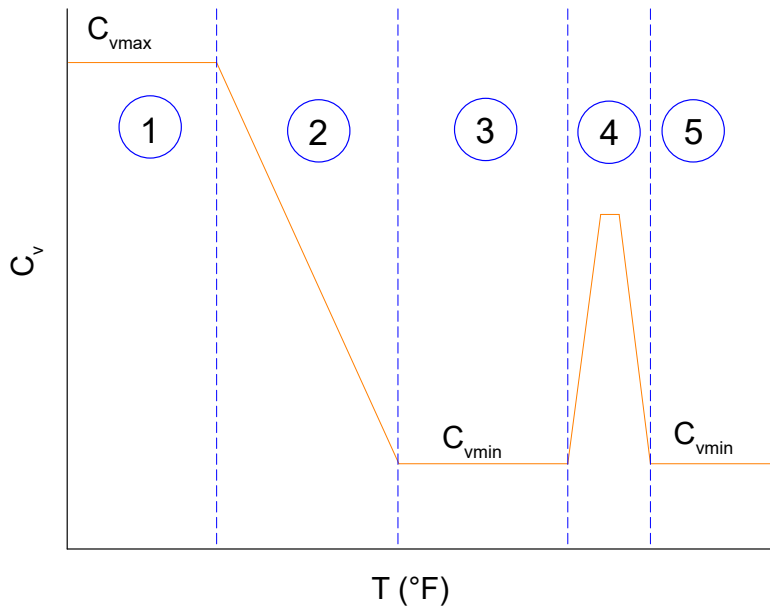

The TB-130G/MG is not a shut-off valve: an amount of flow, C_{vmin} is continuously circulating through the valve even when in its “closed” position. The TB-130G/MG is designed with an automatic disinfect feature to bypass at the fixed pre-set temperature of 160°F.

Working Area 1 - Maximum C_{vmax} , $T_{water} \ll T_{desiredrecirc}$

In this temperature range, the valve is completely open and a spring is balancing the thermostatic cartridge

Working Area 2 - Variable C_v , when T_{water} is reaching $T_{desiredrecirc}$

When the water temperature is approaching the selected balancing temperature, the thermostatic cartridge is expanding until it reaches the “closed” position where the minimum flow is met, C_{vmin}

Working Area 3 - C_{vmin} , $T_{water} \geq T_{desiredrecirc}$

When the water temperature is higher than the selected temperature, the thermostatic cartridge is keeping the valve in “closed” position and the minimum flow occurs, C_{vmin}

Working Area 4 - C_{disinf} , $T_{water} \geq T_{disinf}$

The thermal disinfection cartridge allows increased water flow through the valve when the temperature reaches the disinfection value (factory selected at 160°F and not modifiable by end user)

Working Area 5 - C_{vmin} , $T_{water} \geq T_{disinf}$

When the water temperature is higher than the disinfection point, the flow is reduced to C_{vmin}

TB-130G | disinfect

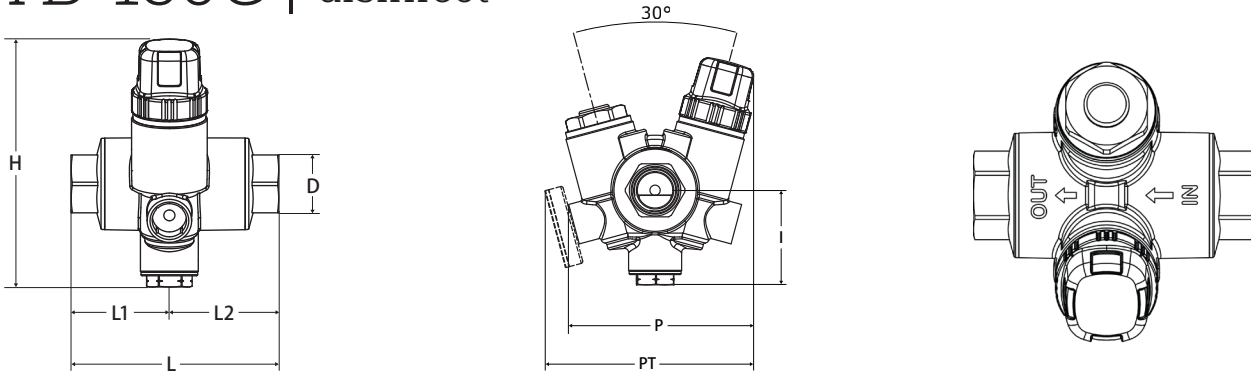

TB-130G	PART NO	D	L	L1	L2	H	I	P	PT
FXF	180-103G-D	1/2"	3.66	1.73	1.93	4.41	1.81	3.58	4.01
FXF	180-104G-D	3/4"	3.9	1.85	2.05	4.41	1.81	3.58	4.01

TB-130G | disinfect + check valve

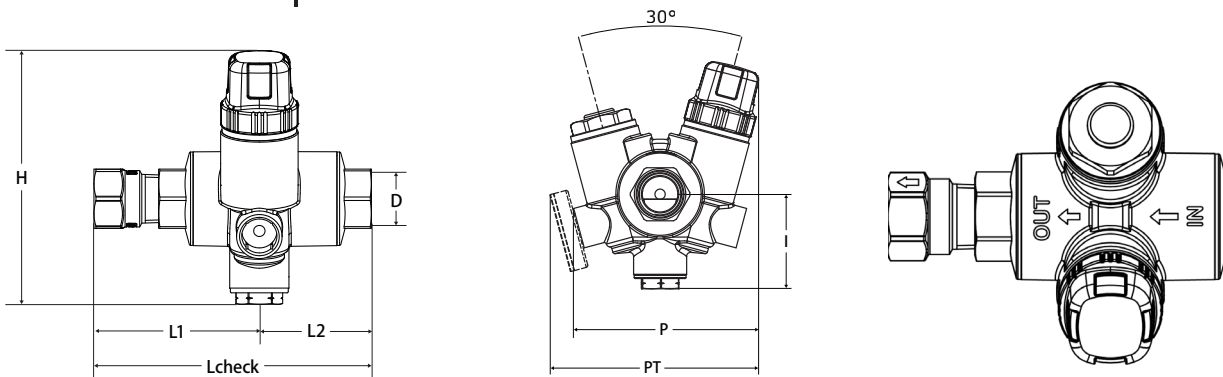

TB-130G	PART NO	D	L _{CHECK}	L1	L2	H	I	P	PT
FXF	180-103G-D-C	1/2"	4.8	2.87	1.93	4.41	1.81	3.58	4.02
FXF	180-104G-D-C	3/4"	5.43	3.39	2.05	4.41	1.81	3.58	4.02

TB-130MG | disinfect + dual isolation + integrated check valve

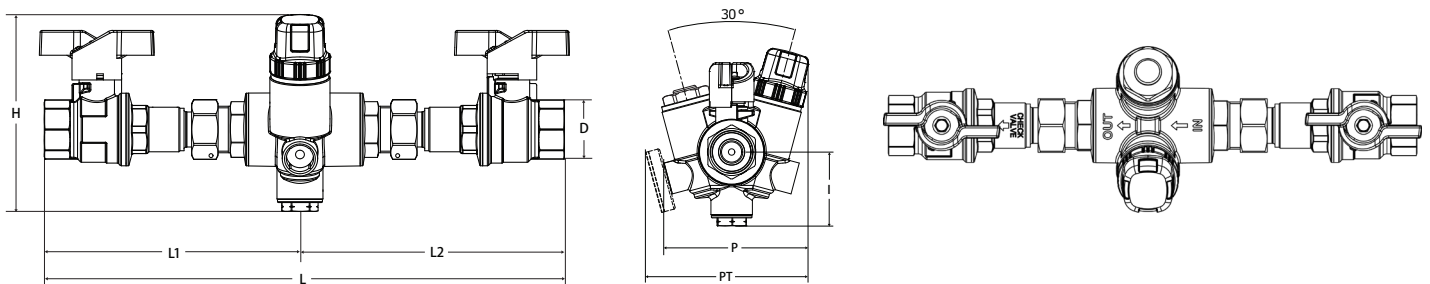

TB-130MG	PART NO	D	L	L1	L2	H	I	P	PT
FXF	180-103MG-D-I	1/2"	11.5	5.75	5.75	4.41	1.81	3.58	4.02
FXF	180-104MG-D-I	3/4"	11.5	5.75	5.75	4.41	1.81	3.58	4.02



TB-150G & TB-150MG

RECIRCSETTER™

ACTUATED

THERMAL DISINFECTION

By using the RecircSetter™ model TB-150G/MG, it is possible to completely control the disinfect procedure by using an actuated bypass. These models allow the end user to choose their thermal disinfection temperature, duration, and frequency through a Building Maintenance System (BMS).

With a specific BMS, it is possible to detect water temperature and control the actuator within the valve in order to fully control the thermal disinfection procedure. Advantages include: monitoring the procedure branch by

branch; controlling the duration of the operation; controlling the temperature of the disinfection procedure at any time; and controlling the temperature that should exceed 158°F.

The RecircSetter™ TB-150G is available in three configurations: (1) axial valve; (2) axial valve + check valve; (3) axial valve + dual isolation + integrated check valve. Each model can also be equipped with a thermoelectric actuator.

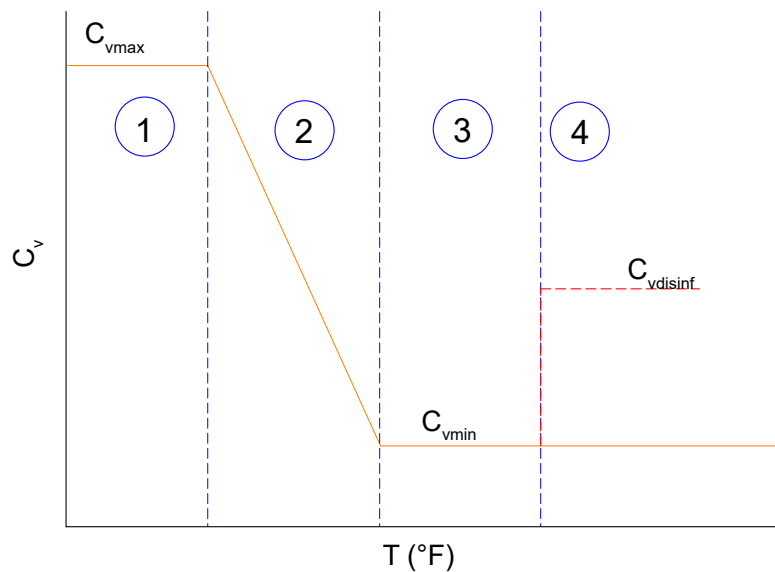

The TB-150G/MG is not a shut-off valve: an amount of flow, C_{vmin} is continuously circulating through the valve even when in its "closed" position.

Working Area 1 - Maximum $C_{vmax} \cdot T_{water} \ll T_{desiredrecirc}$

In this temperature range, the valve is completely open and a spring is balancing the thermostatic cartridge

Working Area 2 - Variable C_v , when T_{water} is reaching $T_{desiredrecirc}$

When the water temperature is approaching the selected balancing temperature, the thermostatic cartridge is expanding until it reaches the "closed" position where the minimum flow is met, C_{vmin}

Working Area 3 - $C_{vmin} \cdot T_{water} \geq T_{desiredrecirc}$

When the water temperature is higher than the selected temperature, the thermostatic cartridge is keeping the valve in "closed" position and the minimum flow occurs, C_{vmin}

Working Area 4 - $C_{vdisinf}$

To work in this area, the below conditions must be met simultaneously:

- Water temperature over 158°F
- The actuator must be open

Such conditions are typically controlled by an external control or BMS (not included).

TB-150G | axial valve

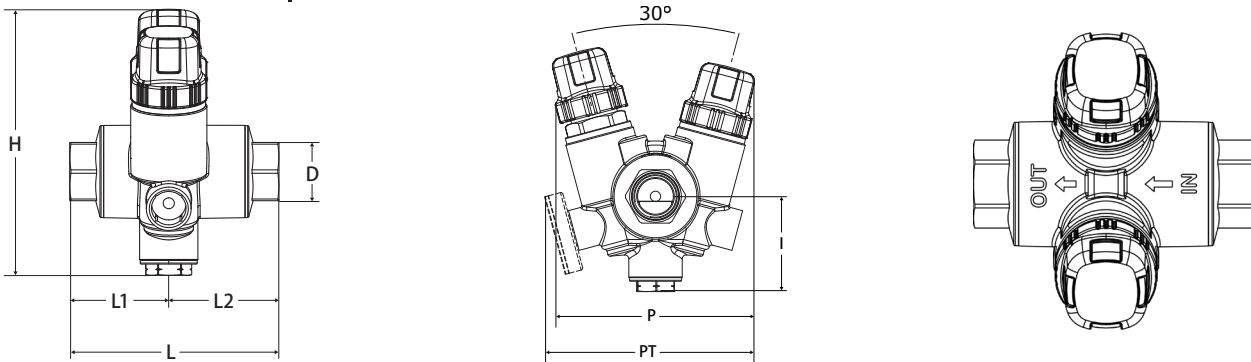

TB-150G	PART NO	D	L	L1	L2	H	I	P	PT
FXF	180-103G-X	1/2"	3.66	1.73	1.93	4.69	1.81	3.82	4.02
FXF	180-104G-X	3/4"	3.9	1.85	2.05	4.69	1.81	3.82	4.02

TB-150G | axial valve + check valve

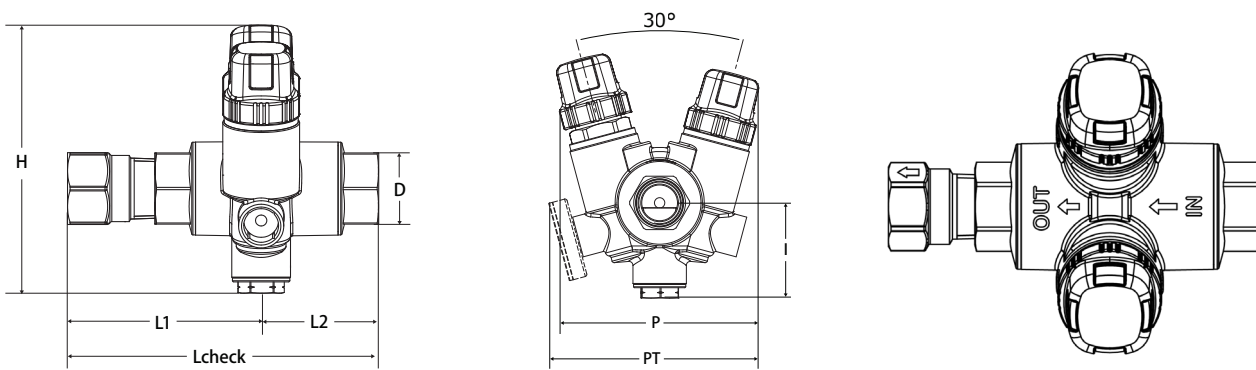

TB-150G	PART NO	D	L _{CHECK}	L1	L2	H	I	P	PT
FXF	180-103G-X-C	1/2"	4.8	2.87	1.93	4.41	1.81	3.58	4.02
FXF	180-104G-X-C	3/4"	5.43	3.39	2.05	4.41	1.81	3.58	4.02

TB-150MG | axial valve + dual isolation + integrated check valve

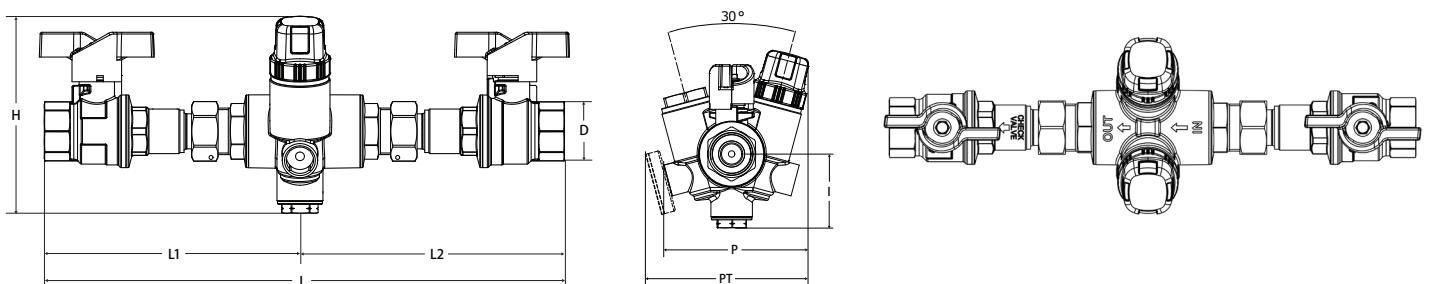

TB-150MG	PART NO	D	L	L1	L2	H	I	P	PT
FXF	180-103MG-X-I	1/2"	11.5	5.75	5.75	4.41	1.81	3.58	4.02
FXF	180-104MG-X-I	3/4"	11.5	5.75	5.75	4.41	1.81	3.58	4.02

TB-150G | actuator

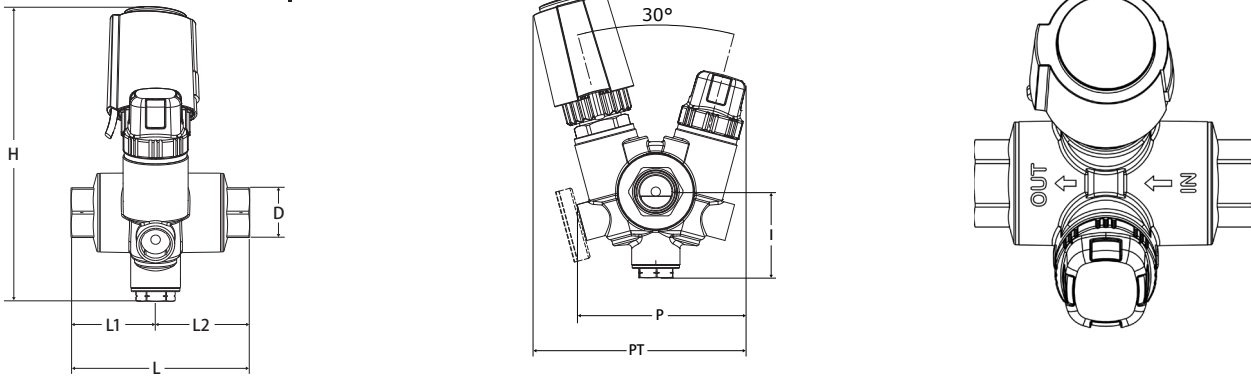

TB-150G	PART NO	D	L	L1	L2	H	I	P	PT
FXF	180-103G-A	1/2"	3.66	1.73	1.93	6.06	1.81	3.58	4.49
FXF	180-104G-A	3/4"	3.9	1.85	2.05	6.06	1.81	3.58	4.49

TB-150G | actuator + check valve

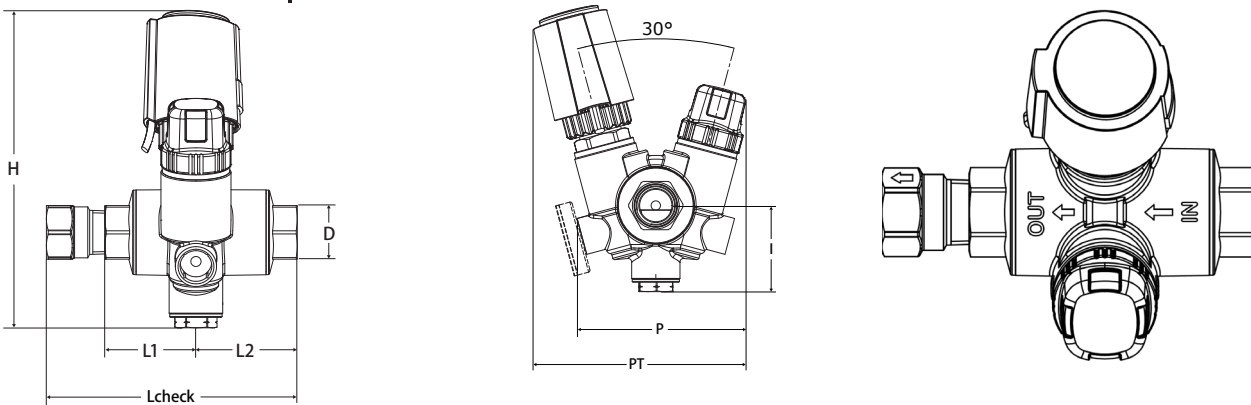

TB-150G	PART NO	D	L _{CHECK}	L1	L2	H	I	P	PT
FXF	180-103G-A-C	1/2"	4.8	1.73	1.93	6.06	1.81	3.58	4.49
FXF	180-104G-A-C	3/4"	5.43	1.85	2.05	6.06	1.81	3.58	4.49

TB-150MG | actuator + dual isolation + integrated check valve

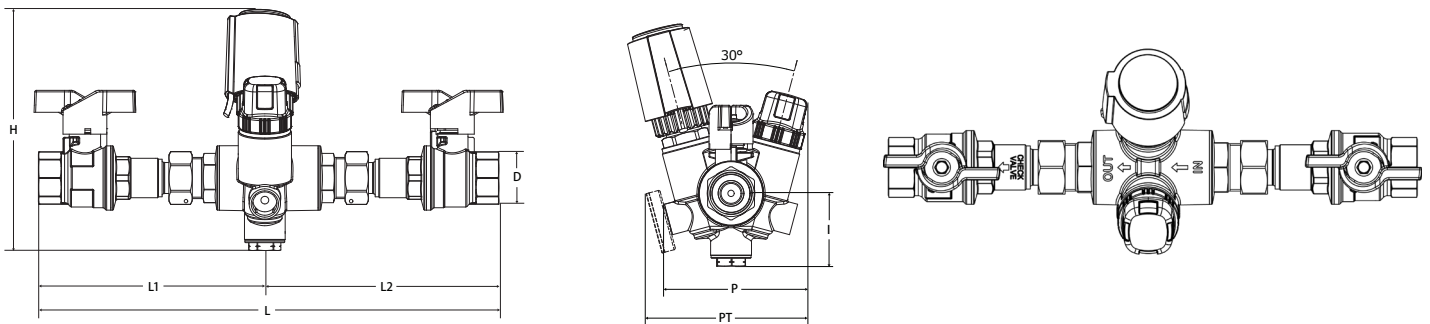

TB-150MG	PART NO	D	L	L1	L2	H	I	P	PT
FXF	180-103MG-A-I	1/2"	11.5	5.75	5.75	6.06	1.81	3.82	4.49
FXF	180-104MG-A-I	3/4"	11.5	5.75	5.75	6.06	1.81	3.82	4.49

PRESETTING OPERATION

The RecircSetter™ has a factory presetting of 125°F (equal to position ▼ on the hand wheel selector). The user can change the presetting by:

1. Removing the hand wheel protective cap
2. Turning the selector to the target position
3. Replacing the hand wheel protective cap on the valve to prevent tampering in the field

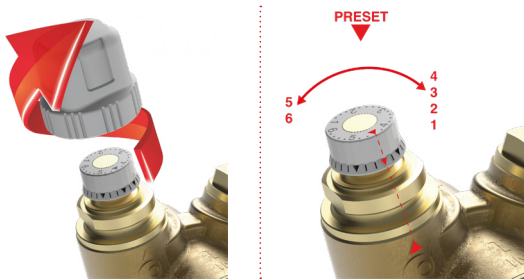

HAND WHEEL SETPOINT TEMPERATURE (°F)									
95°	100°	105°	110°	115°	120°	125°	130°	135°	140°
1	1.6	2.1	2.7	3.2	3.9	▼ 4.4	4.9	5.5	6

Selecting a temperature 3°F - 5°F higher than the desired temperature at the index fixture is suggested to reduce the system's pressure drops and to be able to select the appropriate pump for the recirculation system.

INSTALLATION

The RecircSetter™ can be installed at the end of the branch, with the following considerations:

1. The valve must be accessible for the maintenance team
2. The valve is at least 20 inches from the headers
3. The valve is oriented with the correct flow direction (Fig. 1)
4. The valves must not be installed in series of one another

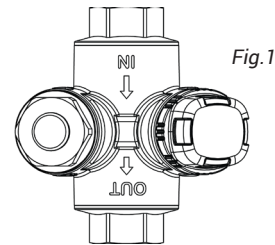

TB-120G & TB-130G

The RecircSetter™ can be installed in both the vertical and horizontal position.

TB-150G

The RecircSetter™ TB-150G/MG model can be equipped with an actuator and must follow standard rules for valve orientation.

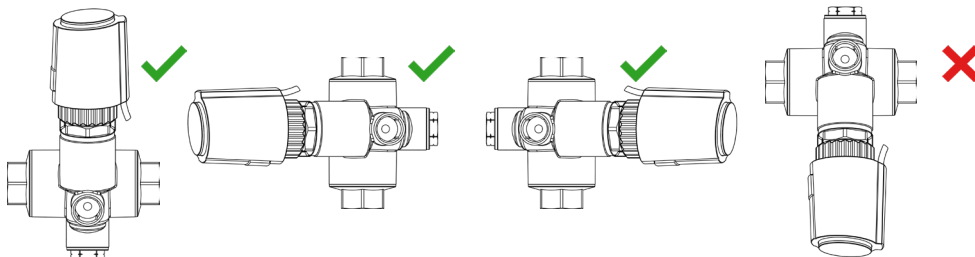

ALL MODELS

It is best practice - and in some cases, required by code - for balancing valves installed within HVAC or potable water applications to use a strainer with the appropriate mesh size.

ACCESSORIES

TAIL PIECE CHECK VALVE

INSTALLED ON
DOWNSTREAM SIDE OF
ALL MODELS

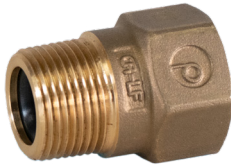

PART NO	SIZE
180-503G	1/2"
180-504G	3/4"

UNION BALL VALVE

FOR DUAL ISOLATION
IN MG MODELS

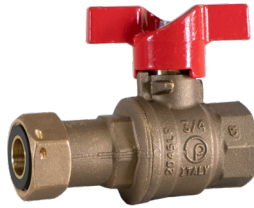

PART NO	SIZE
180-703G	1/2"
180-704G	3/4"

UNION BALL VALVE

WITH INTEGRATED
CHECK VALVE; FOR DUAL
ISOLATION IN MG MODELS



PART NO	SIZE
180-713G	1/2"
180-714G	3/4"

N.C. THERMOELECTRIC ACTUATOR 24V

EQUIPPED WITH LIMIT MICRO
SWITCH AND VA64 RING NUT



PART NO
180-893

DOUBLE SCALE THERMOMETER

32°F - 176°F



PART NO
899-180

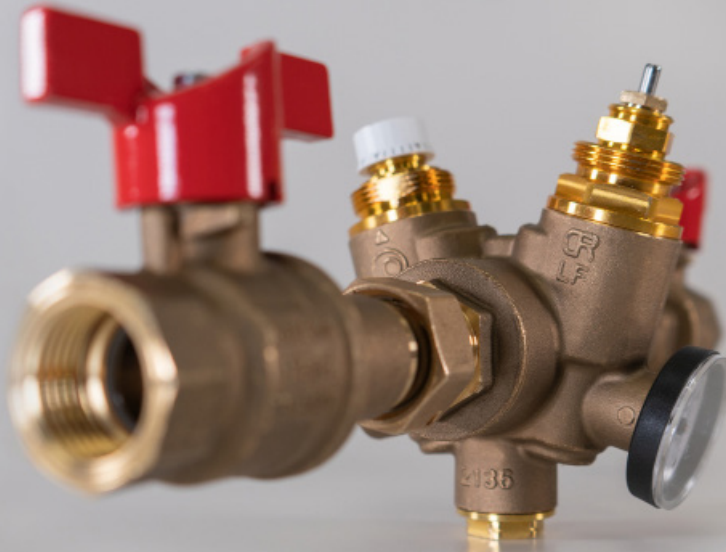

EXAMPLE CALCULATIONS

To design the system properly, evaluation of each component's pressure drop is necessary for the appropriate pump sizing.

Consider a building with three floors and five branches for sanitary water, each consisting of **hot water (HW) branches**, **cold water branches (CW)** and **hot water recirculation (R)**.

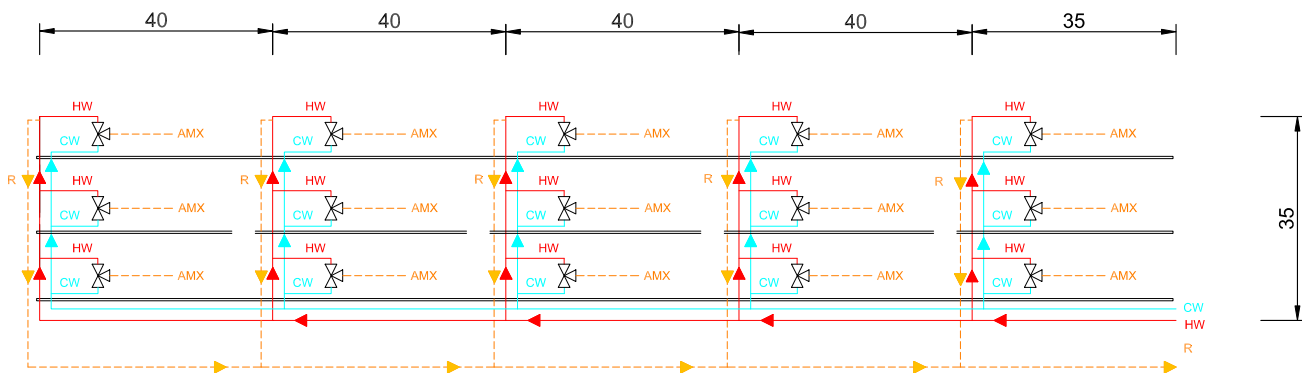

To guarantee a temperature drop that is not more than 10°F, one must take into consideration the thermal losses of the complete line.

Three example calculations follow:

1. Standard thermostatic balancing (full system)
2. Thermal disinfection (all branches simultaneously)
3. Actuated thermal disinfection (1 branch at a time)

1 STANDARD THERMOSTATIC BALANCING (FULL SYSTEM)

TB-120G

ASSUMPTIONS: WATER HEATER TEMP..... 135°F
 RECIRCSETTER™ SETPOINT POSITION..... 125°F
 C_v TEMP..... 125°F
 HEAT LOSS (h)..... 10 BTU/ft/hr
 ΔT..... 10°F

BRANCH	VERTICAL TOTAL LENGTH (HW + R)	BRANCH THERMAL LOSSES (HW + R)	HORIZONTAL MANIFOLD LENGTH	HORIZONTAL MANIFOLD THERMAL LOSSES	THERMAL LOSSES (VERTICAL + HORIZONTAL)	TOTAL THERMAL LOSSES	BRANCH FLOW RATE	FLOW RATE ON THE BRANCH <small>GPM = $\left(\frac{BTU}{500\Delta T}\right)$</small>
	(FT)	(BTU)	(FT)	(BTU)	(BTU)	(BTU)	(GPM)	(GPM)
1	70	700	35	350	1050	5450	0.15	1.09
2	70	700	40	400	1100	4400	0.16	0.94
3	70	700	40	400	1100	3300	0.19	0.78
4	70	700	40	400	1100	2200	0.23	0.59
5	70	700	40	400	1100	1100	0.36	0.36

INDEX:
 FLOW RATE (GPM) 0.36
 C_v 0.59
 ΔP (PSI) 0.37

$$\Delta P = \left(\frac{GPM}{C_v}\right)^2$$

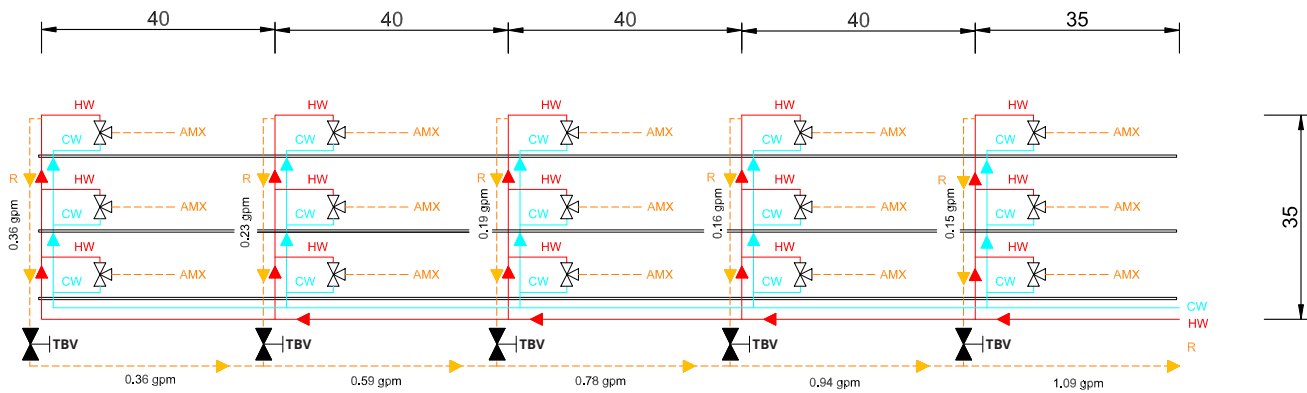

Calculate the GPM required at the pump based on Σ thermal losses and back out the flow rate proportionally for each branch until the furthest branch from the pump has been reached.

$$GPM = \left(\frac{BTU}{500\Delta T}\right)$$

Once the flow rate for the furthest branch has been determined [0.36 GPM based on the assumptions of water distribution temperature (135°F) and maximum allowable ΔT (10°F)], it is possible to calculate pressure drop using the default hand wheel setting curve (Pos. ▼=125°F).

RECIRCSETTER™ • TB-120G • TB-130G • TB-150G

1/2" & 3/4"

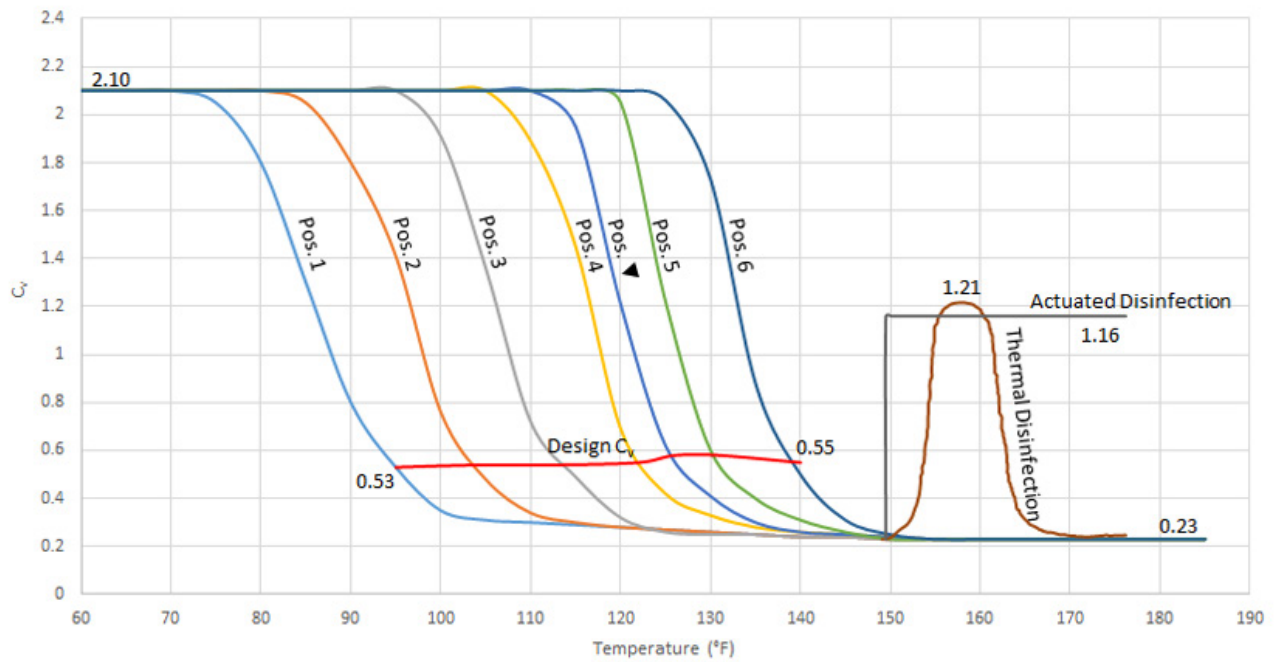

Locate the design C_v for the (Pos. ▼=125°F) curve and calculate the pressure drop as follows:

$$\Delta P = \left(\frac{\text{GPM}}{C_v} \right)^2 = \left(\frac{.36}{.59} \right)^2 = 0.37 \text{ psi}$$

At this pressure drop, one must sum:

1. Headers and risers' pressure drop.
2. Recirculation pressure drop at the index valve furthest from the pump.

The total pressure drop together with the flow value must be used to select the appropriate pump.

For additional detail, see Design C_v Guide.

2 THERMAL DISINFECTION (ALL BRANCHES SIMULTANEOUSLY)

TB-130G

ASSUMPTIONS: WATER HEATER TEMP..... 168°F
 RECIRCSETTER™ SETPOINT POSITION.... 125°F
 C_v TEMP..... 160°F
 HEAT LOSS (h)..... 15 BTU/ft/hr
 ΔT..... 10°F

BRANCH	VERTICAL TOTAL LENGTH (HW + R)	BRANCH THERMAL LOSSES (HW + R)	HORIZONTAL MANIFOLD LENGTH	HORIZONTAL MANIFOLD THERMAL LOSSES	THERMAL LOSSES (VERTICAL + HORIZONTAL)	TOTAL THERMAL LOSSES	BRANCH FLOW RATE	FLOW RATE ON THE BRANCH <small>GPM = $\left(\frac{BTU}{500\Delta T}\right)$</small>
	(FT)	(BTU)	(FT)	(BTU)	(BTU)	(BTU)	(GPM)	(GPM)
1	70	1050	35	525	1575	8175	0.22	1.64
2	70	1050	40	600	1650	6600	0.25	1.41
3	70	1050	40	600	1650	4950	0.28	1.16
4	70	1050	40	600	1650	3300	0.34	0.88
5	70	1050	40	600	1650	1650	0.54	0.54

INDEX:
 FLOW RATE (GPM) 0.54
 C_v 1.21
 ΔP (PSI) 0.20

$$\Delta P = \left(\frac{GPM}{C_v}\right)^2$$

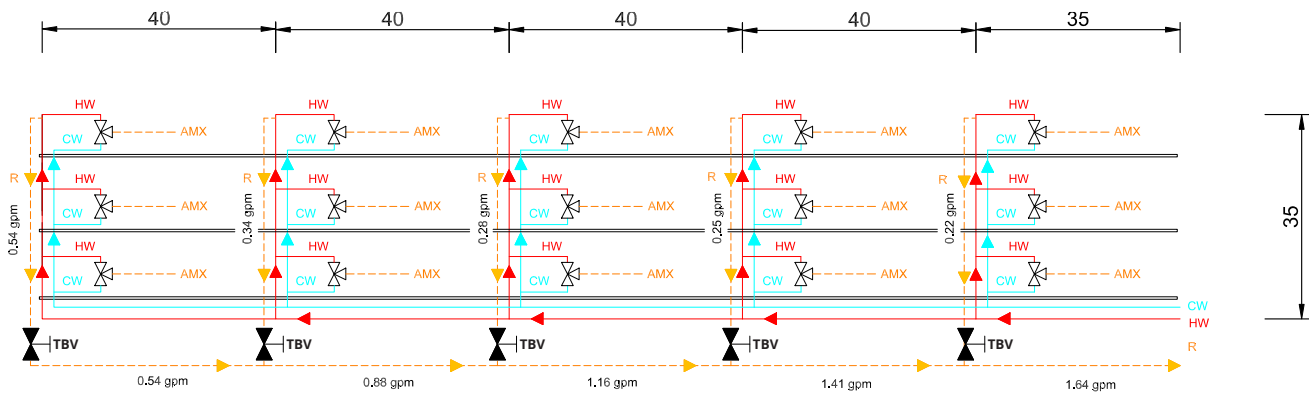

Calculate the GPM required at the pump based on Σ thermal losses and back out the flow rate proportionally for each branch until the furthest branch from the pump has been reached.

$$GPM = \left(\frac{BTU}{500\Delta T}\right)$$

Once the flow rate for the furthest branch has been determined [0.54 GPM based on the assumptions of water distribution temperature (168°F) and maximum allowable ΔT (10°F)], it is possible to calculate pressure drop using the Thermal Disinfection curve.

RECIRCSETTER™ • TB-120G • TB-130G • TB-150G
1/2" & 3/4" WITH CHECK VALVE

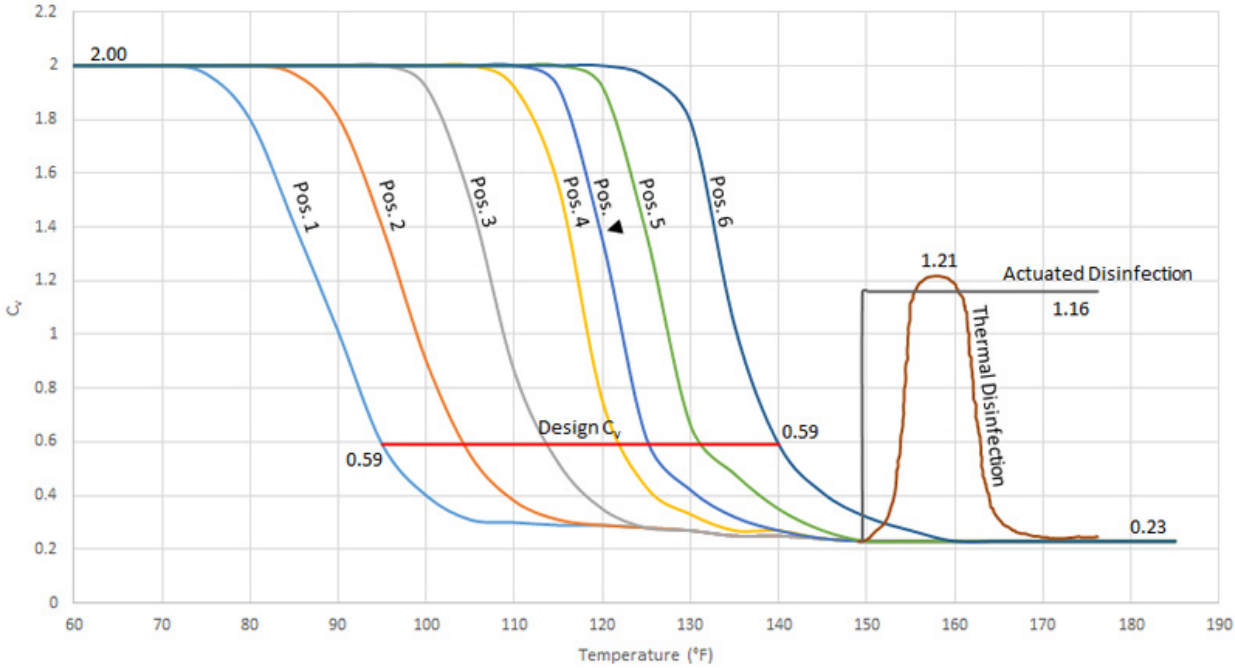

Locate the Cv for the Thermal Disinfection curve at 160°F and calculate the pressure drop as follows:

$$\Delta P = \left(\frac{\text{GPM}}{C_v} \right)^2 = \left(\frac{.54}{1.21} \right)^2 = 0.20 \text{ psi}$$

At this pressure drop, one must sum:

1. Headers and risers' pressure drop.
2. Recirculation pressure drop at the index valve furthest from the pump.

The total pressure drop together with the flow value must be used to select the appropriate pump.

For additional detail, see Design Cv Guide.

3 ACTUATED THERMAL DISINFECTION (1 BRANCH AT A TIME)

TB-150G

ASSUMPTIONS: WATER HEATER TEMP..... 168°F
 RECIRCSETTER™ SETPOINT POSITION.... 125°F
 C_v TEMP..... 160°F
 HEAT LOSS (h)..... 15 BTU/ft/hr
 ΔT..... 10°F

BRANCH	VERTICAL TOTAL LENGTH (HW + R)	BRANCH THERMAL LOSSES (HW + R)	HORIZONTAL MANIFOLD LENGTH	HORIZONTAL MANIFOLD THERMAL LOSSES	THERMAL LOSSES (VERTICAL + HORIZONTAL)	TOTAL THERMAL LOSSES	BRANCH FLOW RATE	FLOW RATE ON THE BRANCH <small>GPM = $\left(\frac{BTU}{500\Delta T}\right)$</small>
	(FT)	(BTU)	(FT)	(BTU)	(BTU)	(BTU)	(GPM)	(GPM)
1	70	1050	35	525	-	3975	-	0.80
2	70	1050	40	600	-	3975	-	0.80
3	70	1050	40	600	-	3975	-	0.80
4	70	1050	40	600	-	3975	-	0.80
5	70	1050	40	600	3975	3975	-	0.80

INDEX:
 FLOW RATE (GPM) 0.80
 C_v 1.16
 ΔP (PSI) 0.47

$$\Delta P = \left(\frac{GPM}{C_v}\right)^2$$

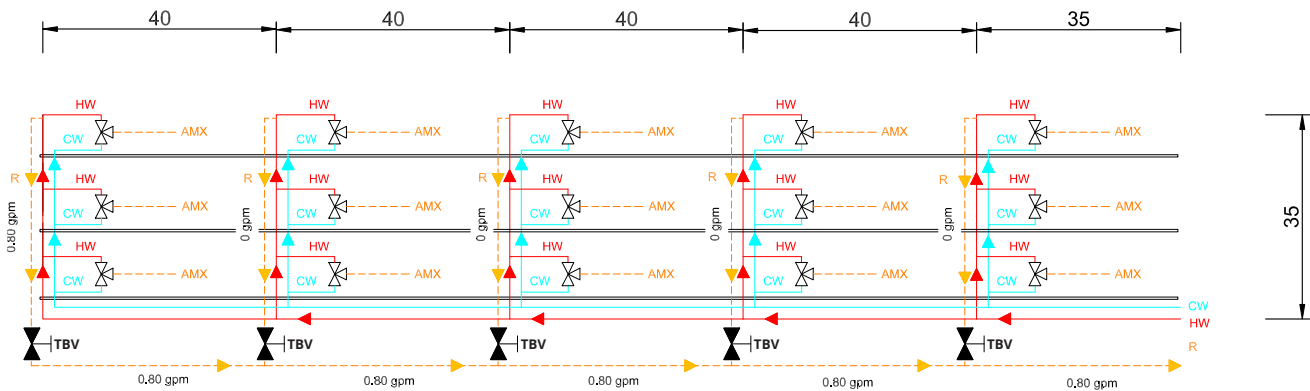

Calculate the GPM required at the pump based on thermal loss through the furthest branch.

$$GPM = \left(\frac{BTU}{500\Delta T}\right)$$

Once the flow rate for the furthest branch has been determined [0.80 GPM based on the assumptions of water distribution temperature (168°F) and maximum allowable ΔT (10°F)], it is possible to calculate pressure drop using the Actuated Disinfection curve.

RECIRCSETTER™ • TB-120G • TB-130G • TB-150G
1/2" & 3/4" WITH DUAL ISOLATION

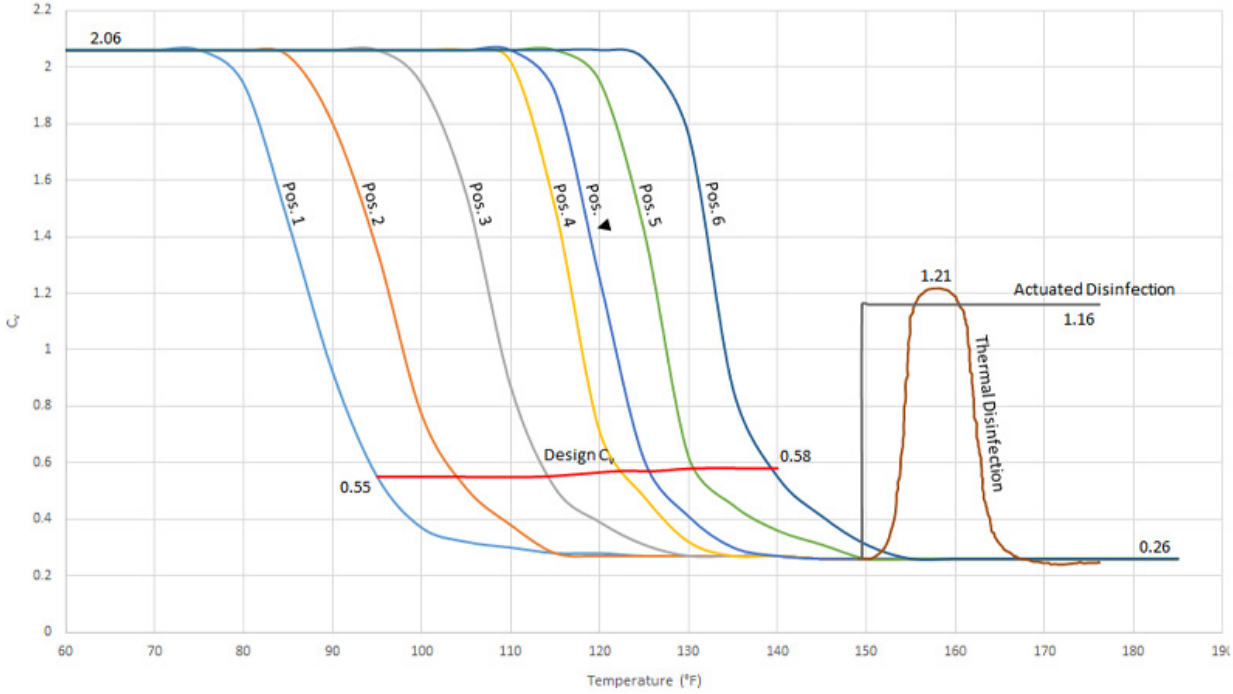

Locate the Cv for the Actuated Disinfection curve at 160°F and calculate the pressure drop as follows:

$$\Delta P = \left(\frac{\text{GPM}}{C_v} \right)^2 = \left(\frac{.80}{1.16} \right)^2 = 0.47 \text{ psi}$$

At this pressure drop, one must sum:

1. Headers and risers' pressure drop.
2. Recirculation pressure drop at the index valve furthest from the pump.

The total pressure drop together with the flow value must be used to select the appropriate pump.

For additional detail, see Design Cv Guide.

DESIGN C_V GUIDE

RECIRCSETTER™ • TB-120G • TB-130G • TB-150G

1/2" & 3/4"

STANDARD MODEL

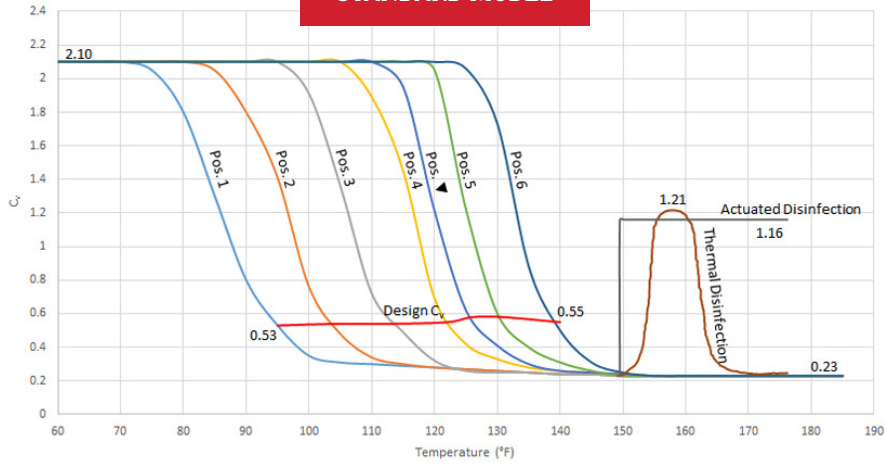

WITH CHECK VALVE

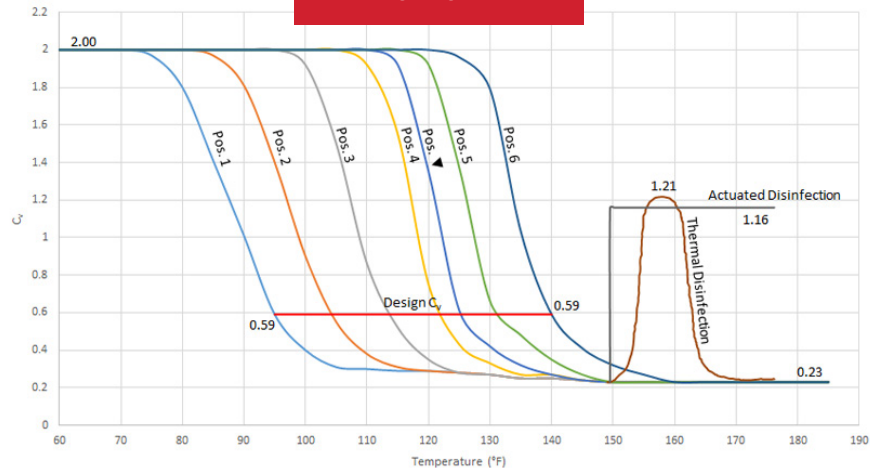

WITH DUAL ISOLATION [MG MODELS]

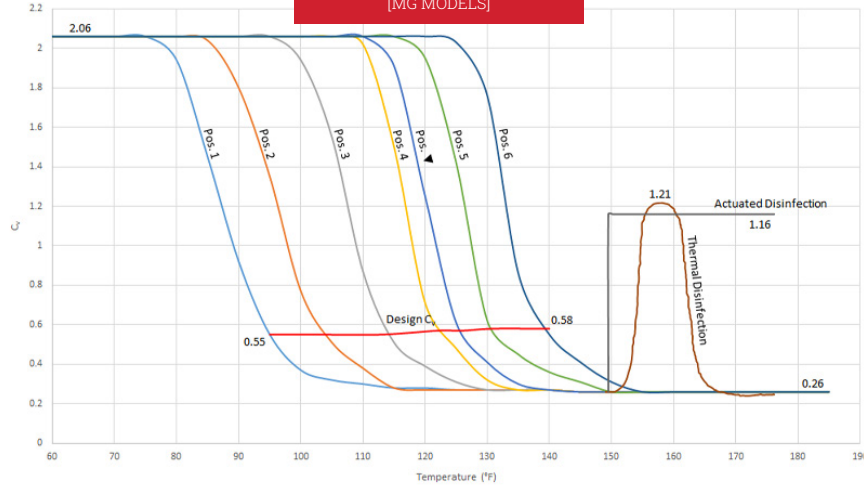



www.jomarvalve.com • csr@jomar.com • P: 586.268.1220 • F: 586.979.8315

LIT-JV-TBV