





Features:

- Power supply 24 Vac/Vdc
- Minimum force 200N [45lbs]
- Control mode: digital (XT models) or analog (XM models)
- Patented Enerdrive Fail-Safe System* (060 models)
- Auto stroke on power up (XM models)
- Anti-stick option (XM models)
- Manual override
- Direct or reverse acting (configurable)
- Status LED
- Standard cable 1 meter (3.2 ft) long
- Easy installation, no tools required
- Small size allows for easy installation in limited space
- Stall-proof, maintenance free
- IP54 enclosure
- Equal percentage available upon request (XM only)

XM000
XM060
XT000
XT060

Technical Data	XM000	XM060	XT000	XT060
Minimum force	200N [45lbs]			
Power supply	22 to 26 Vac or 22 to 26 Vdc			
Power consumption	5VA	10VA peak, 6VA	5VA	10VA peak, 6VA
Electrical connection	4-wire (except XT000 is 3-wire) halogen free cable 0.8 mm ² [18AWG], 1 m (3.2 ft) long			
Control mode & signal	Analog, 0-10Vdc or 2-10Vdc; 4-20mA with external 500Ω resistor		Digital, 2 positions or 3 point floating	
Feedback signal	0-10Vdc or 2-10Vdc		No feedback	
Running time	18.5 sec/mm - 120 sec for 6.5mm			
Failsafe running time	No failsafe	9.2 sec/mm 60 sec for 6.5mm	No failsafe	9.2 sec/mm 60 sec for 6.5mm
Maximum stroke	Up to 6.5 mm [¼ in], self adjustable			
Direction	Reversible, normally up position (close) or normally down position (open)			
Ambient temperature	2°C to 50°C [36°F to 122°F]			
Storage temperature	-30°C to 50°C [-22°F to 122°F]			
Relative humidity	5 to 95 % non condensing			
Medium temperature (in valve)	2°C to 120°C [36°F to 248°F]			
Weight	0.4 kg [0.9 lbs.]			
Ingress protection	IP54 equivalent to NEMA type 3R			
Country of manufacture	Made in Canada			
Certifications	 			

Dimensions

XM000 / XT000

A = 2.08" | 53mm
 B = 4.09" | 104mm
 C = 3.62" | 92mm

adaptor -500

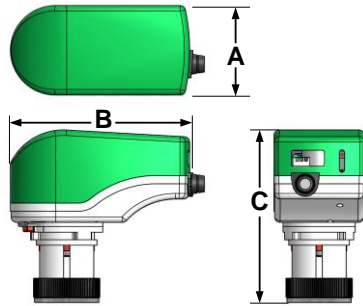

XM060 / XT060

A = 2.08" | 53mm
 B = 4.09" | 104mm
 C = 4.18" | 107mm

adaptor -500

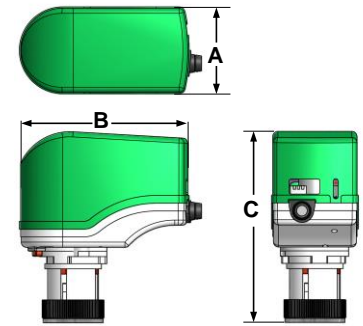

Mechanical installation

Mounting of the actuated valve on system

Correct mounting

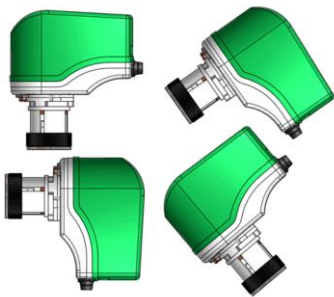

Incorrect mounting



1. The actuated valve installation should be easily accessible and provide sufficient clearance for service and replacement.
2. Horizontal and vertical positions are preferred orientation for the installation of actuated valve. However, this actuator can be installed at any in between angle.

Caution:

Do not install at more than 90° from horizontal.

Mounting of the actuator on valve

ACTUATOR TO VALVE ADAPTOR



No foam insulation above the dotted line and around the adaptor

ACTUATOR

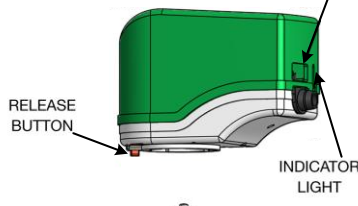

No foam insulation above the dotted line and around the adaptor

1. Mount the valve adaptor to the valve and fingers tighten only.
2. Rotate knob clockwise to open the valve. Do not force knob in either direction!
3. Manually adjust the knob to test piping network.
4. Once satisfied that the network is working properly, engage the actuator over the valve adaptor and turn 30° clockwise (CW). You should hear an audible click.

To disengage the actuator, press the release button while turning the actuator CCW 30°.

Caution:

Actuator specifically calibrated to its adapter. **DO NOT exchange original adapter with a different actuator.**

WARNING!



You must connect the actuator to its adaptor and mount it on a valve before applying power. Failure to do so will result in incorrect operation of the actuator.



If you plan to add foam insulation, do not add insulation foam beyond the chrome ring and around the adaptor. Improper installation of insulation material could lead to a build-up of condensate water around the valve and the chrome ring of the adaptor, which could lead to build up of rust and compromise the structure of the chrome ring that holds the adaptor.

Wiring (XM000 & XM060)

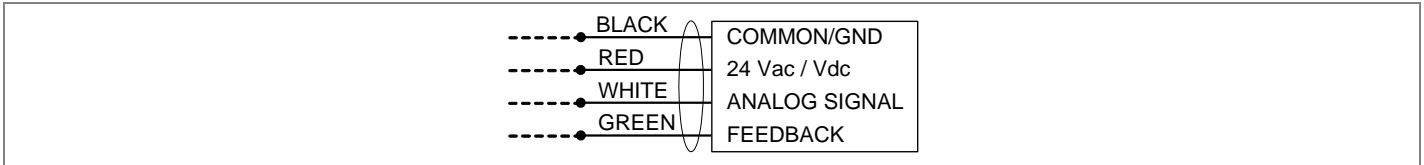

Wiring (XT000)

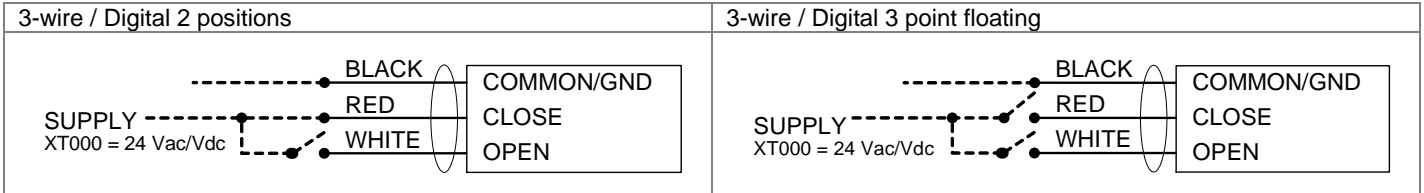

Wiring (XT060)

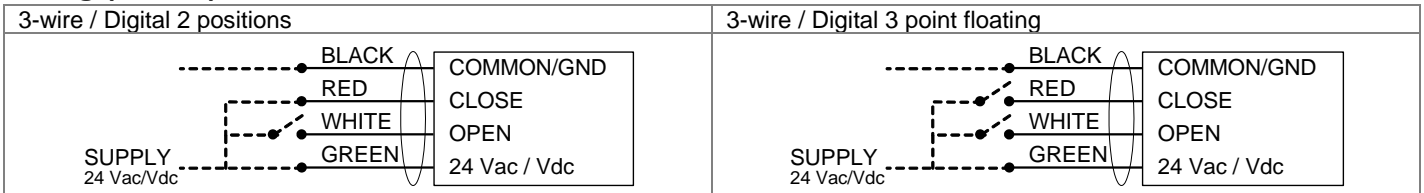

DIP Switches and LED

DIP switches are externally accessible.

XM000

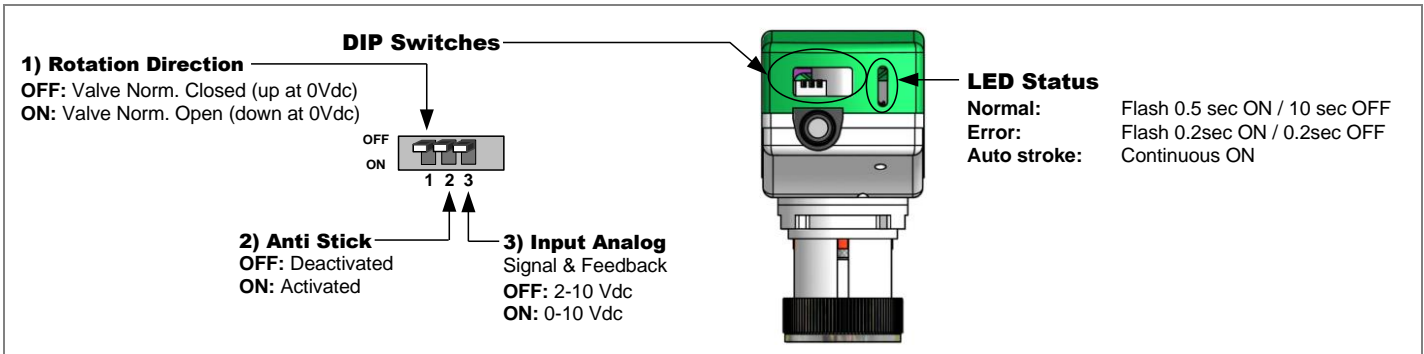

XM060

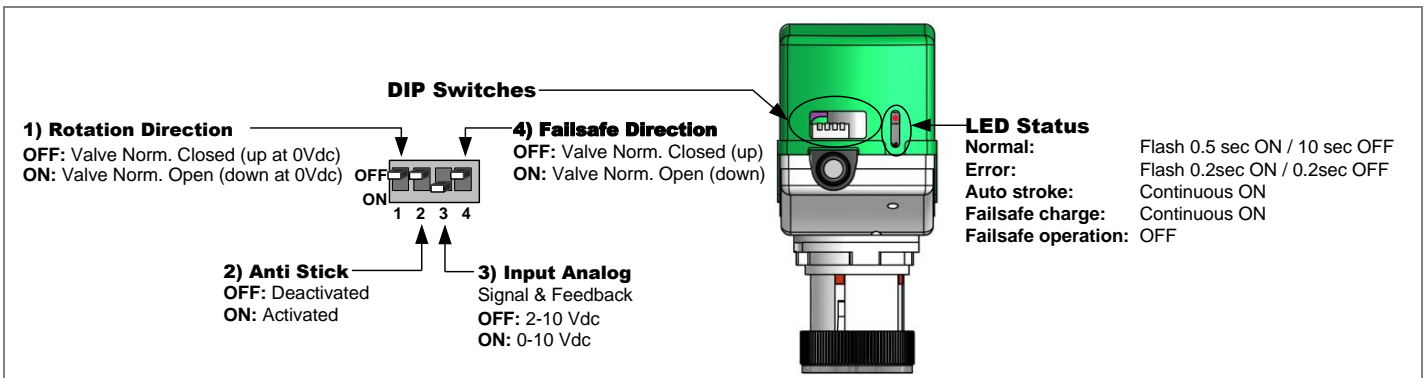

XT000

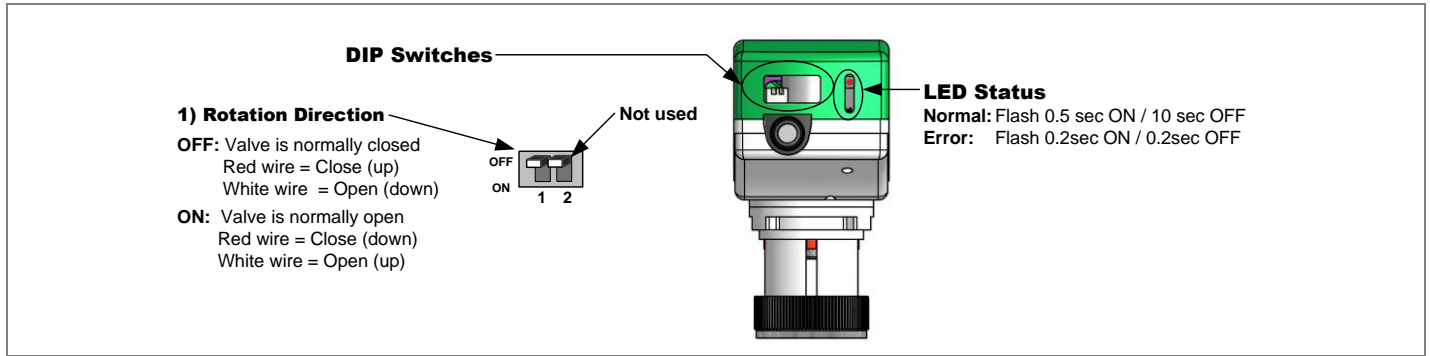

XT060

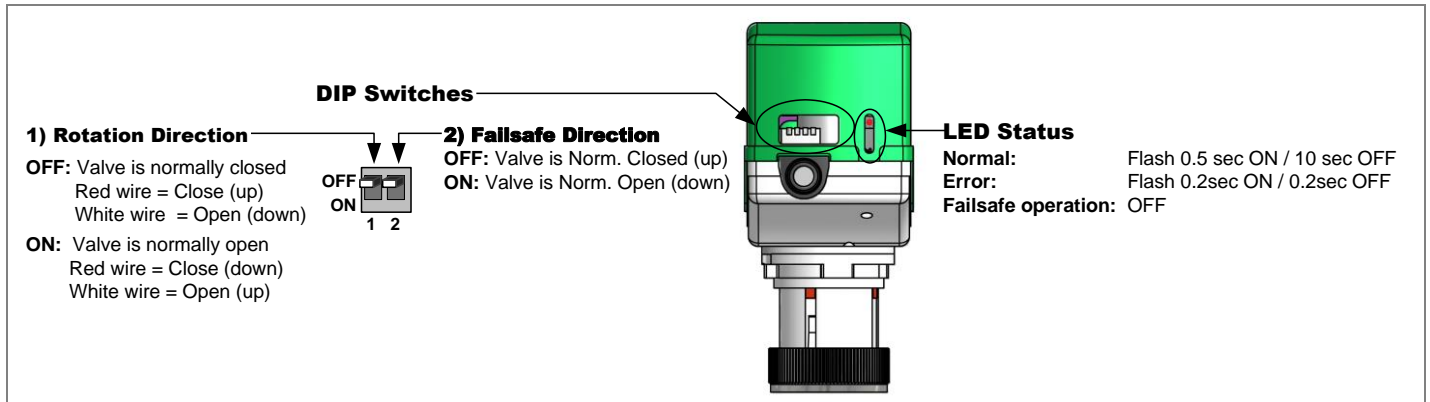

* Enerdrive Fail-Safe System: US Patent # 5,278,454 | European Patent # 0647366

Caution

We strongly recommend that all Neptronic® products be wired to a separate transformer and that transformer shall service only Neptronic® products. This precaution will prevent interference with, and/or possible damage to incompatible equipment. When multiple actuators are wired on a single transformer, polarity must be observed. Long wiring runs create voltage drop which may affect the actuator performance.

Recycling at end of life

 At end of life, please return the thermostat to your Neptronic® local distributor for recycling. If you need to find the nearest Neptronic® authorized distributor, please consult www.neptronic.com.