

9007C

Limit switches

Catalogue
April

04



9007C Limit switches Heavy Duty Industrial

Selection guide *pages 2 and 3*

- **Standard plug-in body metal**
 - Presentation, general characteristics *pages 4 and 5*
 - Characteristics, references *pages 6 to 9*
 - Dimensions *pages 24 and 25*
- **Standard plug-in body metal, reed contacts**
 - Characteristics, references *pages 10 to 13*
 - Dimensions *pages 24 and 25*
- **Compact plug-in body metal**
 - Presentation, general characteristics *pages 4 and 5*
 - Characteristics, references *pages 14 to 17*
 - Dimensions *pages 26 and 27*
- **Factory modifications (Forms) and accessories**
 - Presentation, references *pages 18 to 23*
- **Adaptable sub-assemblies**
 - Presentation *pages 28 and 29*
 - Bodies, heads and lever arms, references *pages 30 to 37*
 - Dimensions *pages 38 and 39*
- **Hazardous location non plug-in body metal**
 - Presentation, general characteristics *pages 40 and 41*
 - Characteristics, references *pages 42 to 45*
 - Dimensions *pages 46 and 47*
- **Technical information**
 - General, applications *pages 48 to 55*
- **Schneider Electric worldwide**
 - Addresses *pages 56 to 61*

Limit switches

9007C Heavy Duty Industrial
Conforming to NEMA 6P and UL 508

Applications	Material handling - mechanical conveying, automotive, machine tool, packaging	
Design	Standard body type 9007C●●●●●	Standard body Reed contacts



Enclosure	Metal, diecast, zinc alloy					
Features	Plug-in body					
Factory modifications	Forms : see pages 18 to 22					
Variable composition switches	Head + body + lever					
Conforming to standards Product	NEMA 6P, EN 60947-1, EN 60947-5-1, IEC 60947, UL 508, C22-2-14-95, C€ conformity documentation					
Product certifications	UL, CSA, C€					
Body dimensions (w x h x d) in mm (inches) with rotary head	39 x 102 x 45 (1.54 x 4.02 x 1.77)					
Head	Linear movement (plunger) Rotary movement (lever) Multi-directional movement (wobble stick, cat whisker)					
Contact blocks	Snap action contacts	1 N.O. + 1 N.C.	2 N.O. + 2 N.C.	2 N.O. + 2 N.C. neutral position	2 N.O. + 2 N.C. two stage	Reed contacts 1 N.O. or 1 N.C.
	Direct opening (positive opening)	9007C●●●● Y1561 → Plunger and lever heads only				
Rated insulation voltage	600 V					
Insulation voltage (Ui) - top half of body	600 V Except: 9007CO62, 9007CO66, 9007CO68 (Ui = 250V) and 9007C84, 9007C86 (Ui = 125V)					
Thermal current (Ithe) - top half of body	10 A Excepted : 9007CO84, 9007CO86 (2.5 A)					
Degree of protection	IP 67 conforming to IEC 60529, NEMA 6P, NEMA 13, NEMA 4, 2, 6, 12					
Connection	Cable entry or connector Depending on model : 1/2"-14 NPT, M20 x 1.5 ISO cable gland, 5 pin mini connector.					

Type reference	9007C54●●●	9007C62●●●	9007C68●●●	9007C66●●●	9007C84●●● 9007C86●●●
-----------------------	------------	------------	------------	------------	--------------------------

Page(s)	6 to 13
----------------	---------

Material handling - mechanical conveying, automotive, machine tool, packaging	Hazardous application locations : gases (explosion), dust environment.
Compact body type 9007C52●●	Hazardous location body type 9007CR●●●●



Metal, diecast, zinc alloy				
Plug-in body		Non plug-in body		
Forms : see pages 18 to 22				
Head + body + lever				
NEMA 6P, EN 60947-1, EN 60947-5-1, IEC 60947, UL 508, C22-2-14-95, CE conformity documentation UL, CSA, CE		NEMA 6P, 7 and 9, EN 60947-1, EN 60947-5-1, IEC 60947, UL 508, C22-2-14-95, CE conformity documentation		
39 x 80 x 45 (1.54 x 3.15 x 1.77)		69 x 156 x 53 (2.72 x 6.14 x 2.10)		
Linear movement (plunger) Rotary movement (lever) Multi-directional movement (wobble stick, cat whisker)				
1 N.O. + 1 N.C.		1 N.O. + 1 N.C.	2 N.O. + 2 N.C.	2 N.O. + 2 N.C. neutral position
9007C●●●● Y1561 →		9007CR●●●● Y1561 →		
600 V		600 V Except: 9007CR63, 9007CR65, 9007CR67 (Ui = 250 V)		
10 A		10 A		
IP 67 conforming to IEC 60529 NEMA 6P, NEMA 13, NEMA 4, NEMA 2, 6, 12		NEMA 7, 9, 6P, 13, 4, 2		
Cable entry or connector Depending on model : 1/2"-14 NPT, M20 X 1.5 ISO cable gland, 5 pin mini connector		Cable entry or connector Depending on model : 1/2"-14 NPT, M20 X 1,5 ISO cable gland, 3/4 14 NPT available		
9007C52●●	9007CR53●●	9007CR61●●	9007CR65●●	9007CR67●●
14 to 17		40 to 47		

Limit switches

9007C Heavy Duty Industrial
Standard and Compact plug-in body metal
Conforming to NEMA 6P and UL 508

■ Standard plug-in body type
with 1 cable entry (1)

■ The standard plug-in body types with 1 cable entry are also available with reed contacts

□ With Reed contacts

□ With Reed contacts

□ With head for linear movement
side plunger

top plunger

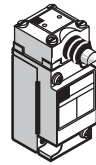
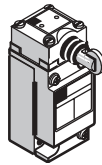

Page 6

Page 7

Page 10

Page 11

□ With head for rotary movement (lever)

With head for multi-directional movement

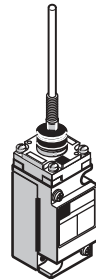
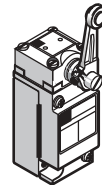
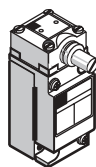

Page 8

Page 9

Page 12

Page 13

■ Compact plug-in body type
with 1 cable entry (1)

□ With head for linear movement
side plunger

top plunger

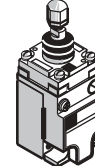
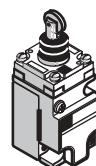
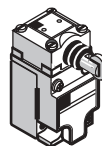
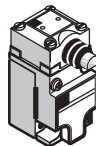

Page 14

Page 15

□ With head for rotary movement (lever)

With head for multi-directional movement

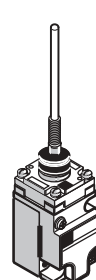
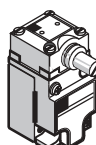

Page 16

Page 17

(1) Factory modifications: see pages 18 to 22

Limit switches

9007C Heavy Duty Industrial
Standard and Compact plug-in body metal
Conforming to NEMA 6P and UL 508

Environment characteristics		
Conforming to standards	Products	NEMA 6P, EN 60947-1, EN 60947-5-1, IEC 60947, UL 508, C22-2-14-95, CE conformity documentation
Product certifications		UL, CSA, CE
Protective treatment		Epoxy powder coat (additional protection available)
Ambient air temperature	Operation	- 20...+ 185 °F (- 28.9...+ 85 °C), wider range available
	Storage	- 20...+ 185 °F (- 28.9...+ 85 °C), wider range available
Vibration resistance	Conforming to IEC 60068-2-6	25 gn (10...150 Hz, 11 ms) (Reed switch good for 18.5g only)
Shock resistance	Conforming to IEC 60068-2-27	60 gn (9 ms) 40 gn (9 ms) for reed switch
Electric shock protection	Conforming to IEC 61140	Class 0
Degree of protection	Conforming to IEC 60529	IP 67
Cable entry or connector	Depending on model	1/2-14 NPT, M20 X 1.5, ISO cable gland, 5 pin mini connector, 4 pin micro connector
Materials	Bodies, heads, levers	Bodies and heads in Zamak (zinc alloy), levers and rods in zinc, steel, stainless steel, delrin.
Contact block characteristics		
Rated operational characteristics hard contacts -AC Voltage (top half of body)	9007CO52 (compact single)	NEMA A600 (Ue = 600 V, Ie = 1.2 A); Ithe = 10 A
	9007CO54 (single pole)	NEMA A600 (Ue = 600 V, Ie = 1.2 A); Ithe = 10 A
	9007CO62 (two pole)	NEMA A600 (Ue = 600 V, Ie = 1.2 A); Ithe = 10 A
	9007CO66 (two pole two stage)	NEMA A600 (Ue = 600 V, Ie = 1.2 A); Ithe = 10 A
	9007CO68 (two pole neutral)	NEMA A600 (Ue = 600 V, Ie = 1.2 A); Ithe = 10 A
Reed switches, complete body	9007C84 (1 N.O.)	NEMA C600 (Ue = 600 V, Ie = 0.3 A); Ithe = 2.5 A
	9007C86 (1 N.C.)	NEMA C600 (Ue = 600 V, Ie = 0.3 A); Ithe = 2.5 A
Rated operational characteristics hard contacts -DC Voltage (top half of body)	9007CO52 (compact single)	NEMA Q600 (Ue = 600 V, Ie = 0.1 A); Ithe = 2.5 A
	9007CO54 (single pole)	NEMA Q600 (Ue = 600 V, Ie = 0.1 A); Ithe = 2.5 A
	9007CO62 (two pole)	NEMA R300 (Ue = 250 V, Ie = 0.11 A); Ithe = 1.0 A
	9007CO66 (two pole two stage)	NEMA R300 (Ue = 250 V, Ie = 0.11 A); Ithe = 1.0 A
	9007CO68 (two pole neutral)	NEMA R300 (Ue = 250 V, Ie = 0.11 A); Ithe = 1.0 A
Reed switches, complete body	9007C84 (1 N.O.)	NEMA Q150 (Ue = 125 V, Ie = 0.55 A); Ithe = 2.5 A
	9007C86 (1 N.C.)	NEMA Q150 (Ue = 125 V, Ie = 0.55 A); Ithe = 2.5 A
Rated insulation voltage		600 V
Rated Impulse Withstand Voltage		2,500 VAC for 1 minute for CE, 2,200 VAC for 1 minute for UL, & 2,640 VAC for 1 sec. for CSA
Positive Opening	Special Y1561	Special Y1561 (one pole slow break only) ☹
Short Circuit Protection		10 A. Bussman Class CC KTK-R-10 fuse Non time delay
Terminal wire sizes (Cabling/Screw Clamp)		1 or 2, 12-22AWG (2.05 mm ² - 0.644 mm ²) wires maximum
Maximum Actuation Speed		15.2 mpm / 27.4 mpm (50 fpm / 90 fpm) with 45 degree cam angle, levers only
Electrical Durability		1 million operating cycles

Types of contact elements

Example : 9007C54 single pole limit switch form Z
same polarity

IEC 60947-5-1			NEMA			JIS		
Form	Symbol	Description	Form	Symbol	Description	Form	Symbol	Description
A		Single break	A		-	3		-
X								Double break
B		Single break	B		-	2		-
Y								Double break
C		-	C		-	1		Single break
Za		Same polarity	Z		"Same polarity" only			Double break
Zb		Electrically separate			-			

Limit switches

9007C Heavy Duty Industrial
Standard plug-in body metal
Conforming to NEMA 6P and UL 508

Type of head Standard plug-in body type	Side Plunger (fixing by the body)			

Type of operator	Side roller plunger spring return vertical roller (1)	Side push rod plunger spring return	Side push rod plunger adjustable (2) spring return	Side push rod plunger maintained contact
------------------	---	-------------------------------------	--	--





References				
1 N.O. 1 N.C. snap action 	9007C54F 	9007C54G 	9007C54GD 	9007C54H
2 N.O. 2 N.C. snap action 	9007C62F 	9007C62G 	9007C62GD 	9007C62H
2 N.O. 2 N.C. Two stage snap action 	9007C66F 	9007C66G 	9007C66GD 	
Weight kg (lb)	0.568 (1.25)	0.568 (1.25)	0.568 (1.25)	0.568 (1.25)
Contact operation				

Characteristics (nominal operating data)				
Switch actuation	On end			
Type of actuation				
Pre-travel	2 mm (0.08")		3.6 mm (0.14")	
Pre-travel two Stage	First stage	2 mm (0.08")		
	First stage to second stage	0.5 mm (0.02")		
Total travel	6.3 mm (0.25")			
Differential	0.8 mm (0.03")			
Reverse overtravel	-			
Mechanical durability in millions of operating cycles	10			
Minimum force or torque	1 pole & 2 pole	4 lb (17.8 N)		7 lb (31.1 N)
Terminal wire sizes (Cabling/Screw Clamp)	1 or 2, 12-22AWG (2.05 mm ² - 0.644 mm ²) wires maximum			
Repeatability (linear travel of cam)	0.03 mm (0.001")		-	
Cable entry	1/2-14 NPT standard, optional M20 x 1.5 mm for ISO cable gland			



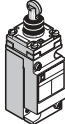

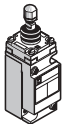



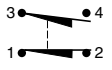
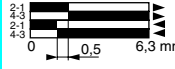

(1) Can be converted to horizontal roller type in the field. To order horizontal roller version add the letter **H** at the end of the equivalent vertical roller version type.
(2) To lock the nut in the desired position, crimp the slot near the bottom of the nut.

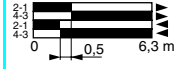
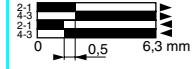
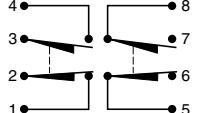
Limit switches

9007C Heavy Duty Industrial
Standard plug-in body metal
Conforming to NEMA 6P and UL 508

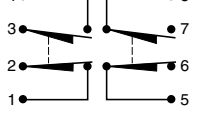
Type of head	Top Plunger (fixing by the body)			
Standard plug-in body type				

Type of operator	Top roller plunger spring return	Top push rod plunger spring return	Top push rod plunger adjustable (1) spring return	Palm operated (2)
-------------------------	----------------------------------	------------------------------------	---	-------------------

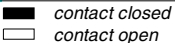
References				
1 N.O. 1 N.C. snap action	9007C54D	9007C54E	9007C54ED	9007C54R (2)
				
2 N.O. 2 N.C. snap action	9007C62D	9007C62E	9007C62ED	9007C62R (2)
				
2 N.O. 2 N.C. Two stage snap action	9007C66D	9007C66E	9007C66ED	9007C66R (2)
				
Weight kg (lb)	0.568 (1.25)	0.568 (1.25)	0.568 (1.25)	0.568 (1.25)
Contact operation				

Characteristics (nominal operating data)	
Switch actuation	On end
Type of actuation	
Pre-travel	2 mm (0.08")
Pre-travel two Stage	First stage: 2 mm (0.08") First stage to second stage: 0.3 mm (0.01")
Total travel	6.3 mm (0.25")
Differential	0.5 mm (0.02")
Reverse overtravel	—
Mechanical durability in millions of operating cycles	10
Minimum force or torque 1 pole & 2 pole	3 lb (13.3 N) 7 lb (31.1 N)
Terminal wire sizes (Cabling/Screw Clamp)	1 or 2, 12-22AWG (2.05 mm ² - 0.644 mm ²) wires maximum
Repeatability (linear travel of cam)	0.03 mm (0.001")
Cable entry	1/2-14 NPT standard, optional M20 x 1.5 mm for ISO cable gland

(1) To lock the nut in the desired position, crimp the slot near the bottom of the nut.
 (2) Does not include mushroom button. Must be ordered separately see page 31.

Limit switches

9007C Heavy Duty Industrial
Standard plug-in body metal
Conforming to NEMA 6P and UL 508

Type of head	Rotary (lever arm type) (1)						
Standard plug-in body type							
Type of operator	Standard pre-travel spring return	Low differential spring return	Neutral position Standard pre-travel spring return		Low differential spring return	Light operating torque spring return	Maintained contact
Type of direction	CW & CCW (2)	CW & CCW (2)	CW & CCW	CW & CCW	CW & CCW (2)	CW (trip) CCW (reset)	
References							
1 N.O. 1 N.C. snap action	 9007C54B2	 9007C54A2			 9007C54N2	 9007C54C	
2 N.O. 2 N.C. snap action	 9007C62B2	 9007C62A2			 9007C62N2	 9007C62C	
2 N.O. 2 N.C. snap action Neutral position			 9007C68T10	 9007C68T5			
2 N.O. 2 N.C. Two stage snap action	 9007C66B2	 9007C66A2			 9007C66N2		
Weight kg (lb)	0.568 (1.25)	0.568 (1.25)	0.568 (1.25)	0.568 (1.25)	0.568 (1.25)	0.568 (1.25)	
Contact operation	contact closed		contact open				

Characteristics (nominal operating data)

Switch actuation	By 30° cam					
Type of actuation						
Pre-travel	10°	5°	10°	5°	10°	45°
Pre-travel two Stage						
- First stage	10°	5°	-	-	10°	-
- First stage to second stage	2.5°	1.5°	-	-	2.5°	-
Total travel	90°					90°
Differential	4°	2°	4°	2°	4°	-
Reverse overtravel	90°					-
Mechanical durability in millions of operating cycles	10					
Operating torque/force 1 pole & 2 pole	4 lb-in (0.45 N.m)				25 oz-in (0.18 N.m)	3 lb-in (0.34 N.m)
Terminal wire sizes (Cabling/Screw Clamp)	1 or 2, 12-22AWG (2.05 mm ² - 0.644 mm ²) wires maximum					
Repeatability (linear travel of cam)	0.05 mm (± 0.002")	0.03 mm (± 0.001")	0.05 mm (± 0.002")	0.05 mm (± 0.002")	0.05 mm (± 0.002")	0.05 mm (± 0.002")
Cable entry	1/2-14 NPT standard, optional M20 x 1.5 mm for ISO cable gland					

(1) Lever arm type must be ordered separately from pages 32 to 37.

(2) These devices are factory set to operate the contacts in **both** the CW and CCW directions. **Mode of operation** is field convertible to CW only or CCW only. **To order factory converted devices** - for CCW only operation, change the "2" at the end of the type number to "1" (Example : C54B2 becomes C54B1) - for CW only operation, delete the "2" at the end of the type number (Example C54B2 becomes C54B).

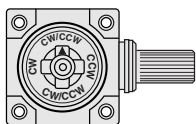

Mode change of lever arm is easily convertible to clockwise, or both. Simply point the arrow to the letters representing the desired direction - CW, CCW, or CW/CCW.

Limit switches

9007C Heavy Duty Industrial
Standard plug-in body metal
Conforming to NEMA 6P and UL 508

Type of head	Flexible operator (wobble stick)				
Standard plug-in body type					

Type of operator	Universal (1)	Wobble stick DELRIN extension (1)	Wobble stick wire extension (1)	Wobble stick coil spring extension (1)	Cat whisker
-------------------------	---------------	-----------------------------------	---------------------------------	--	-------------

References					
1 N.O. 1 N.C. snap action 	9007C54JKC 	9007C54J 	9007C54K 	9007C54KC 	9007C54L
2 N.O. 2 N.C. snap action 	9007C62JKC 	9007C62J 	9007C62K 	9007C62KC 	9007C62L
2 N.O. 2 N.C. Two stage snap action 	9007C66JKC 	9007C66J 	9007C66K 	9007C66KC 	9007C66L
Weight kg (lb)	0.568 (1.25)	0.568 (1.25)	0.568 (1.25)	0.568 (1.25)	0.568 (1.25)
Contact operation					

Characteristics (nominal operating data)

Switch actuation	Object from any direction	
Type of actuation		
Pre-travel	10° (any direction)	20°
Pre-travel two Stage		
- First stage	10° (any direction)	20°
- First stage to second stage	4°	5°
Total travel	90°	
Differential	3	6°
Reverse overtravel	-	
Mechanical durability in millions of operating cycles	10	
Operating torque/force 1 pole & 2 pole	3 lb-in (0.34 N.m)	7 oz-in (0.05 N.m)
Terminal wire sizes (Cabling/Screw Clamp)	1 or 2, 12-22AWG (2.05 mm ² - 0.644 mm ²) wires maximum	
Repeatability (linear travel of cam)	-	
Cable entry	1/2-14 NPT standard, optional M20 x 1.5 mm for ISO cable gland	

(1) **Wobble stick extensions** are available separately for the universal head or as replacements for complete devices (see page 31)

Limit switches

9007C Heavy Duty Industrial
Standard plug-in body metal, Reed contacts
Conforming to NEMA 6P and UL 508

Type of head
Standard plug-in body type

Side Plunger (fixing by the body)



Type of operator	Side roller plunger spring return vertical roller (1)	Side push rod plunger spring return	Side push rod plunger adjustable (2) spring return	Side push rod plunger maintained contact
------------------	---	--	--	---

References

1 N.O. Reed contacts snap action



9007C84F

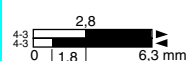

9007C84G

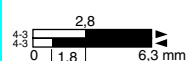

9007C84GD

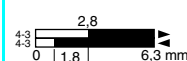

9007C84H

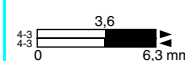

1 N.C. Reed contacts snap action



9007C86F

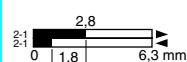

9007C86G

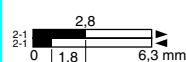

9007C86GD

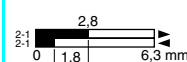

9007C86H

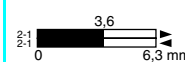

Weight kg (lb)

0.568 (1.25)

0.568 (1.25)

0.568 (1.25)

0.568 (1.25)

Contact operation

contact closed
 contact open

Characteristics (nominal operating data)



Switch actuation	On end	
Type of actuation		
Pre-travel	2.8 mm (0.110")	3.6 mm (0.14")
Total travel	6.3 mm (0.25")	
Differential	1.8 mm (0.07")	–
Reverse overtravel	–	
Mechanical durability in millions of operating cycles	10	
Minimum force or torque 1 pole & 2 pole	4 lb (17.8 N)	7 lb (31.1 N)
Terminal wire sizes (Cabling/Screw Clamp)	1 or 2, 12-22AWG (2.05 mm ² - 0.644 mm ²) wires maximum	
Repeatability (linear travel of cam)	0.076 mm (± 0.003")	–
Cable entry	1/2-14 NPT standard, optional M20 x 1.5 mm for ISO cable gland	

(1) Can be converted to horizontal roller type in the field. To order horizontal roller version add the letter **H** at the end of the equivalent vertical roller version type.

(2) To lock the nut in the desired position, crimp the slot near the bottom of the nut.

Limit switches

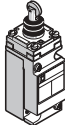
9007C Heavy Duty Industrial
Standard plug-in body metal, Reed contacts
Conforming to NEMA 6P and UL 508

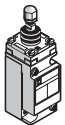
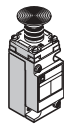
Type of head Standard plug-in body type	Top Plunger (fixing by the body)			
				

Type of operator	Top roller plunger spring return	Top push rod plunger spring return	Top push rod plunger adjustable (1) spring return	Palm operated (2)
-------------------------	----------------------------------	------------------------------------	---	-------------------

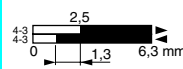
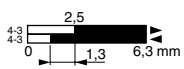
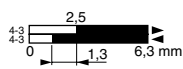
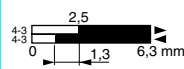
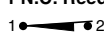
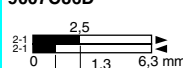
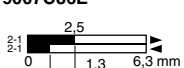
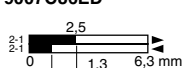
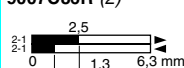
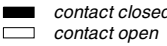
References				
1 N.O. Reed contacts snap action 	9007C84D 	9007C84E 	9007C84ED 	9007C84R (2) 
1 N.C. Reed contacts snap action 	9007C86D 	9007C86E 	9007C86ED 	9007C86R (2) 
Weight kg (lb)	0.568 (1.25)	0.568 (1.25)	0.568 (1.25)	0.568 (1.25)
Contact operation	 ■ contact closed □ contact open			

Characteristics (nominal operating data)	
Switch actuation	On end
Type of actuation	
Pre-travel	2.5 mm (0.100")
Total travel	6.3 mm (0.25")
Differential	1.3 mm (0.05")
Reverse overtravel	—
Mechanical durability in millions of operating cycles	10
Minimum force or torque 1 pole & 2 pole	4 lb (17.8 N)
Terminal wire sizes (Cabling/Screw Clamp)	1 or 2, 12-22AWG (2.05 mm ² - 0.644 mm ²) wires maximum
Repeatability (linear travel of cam)	0.076 mm (± 0.003")
Cable entry	1/2-14 NPT standard, optional M20 x 1.5 mm for ISO cable gland

(1) To lock the nut in the desired position, crimp the slot near the bottom of the nut.

(2) Does not include mushroom button. Must be ordered separately from page 31.

Limit switches

9007C Heavy Duty Industrial
Standard plug-in body metal, Reed contacts
Conforming to NEMA 6P and UL 508

Type of head	Rotary (lever arm type) (1)			
Standard plug-in body type				



Type of operator	Standard pre-travel spring return	Low differential spring return	Light operating torque spring return	Maintained contact
Type of direction	CW & CCW (2)	CW & CCW (2)	CW & CCW (2)	CW (trip) CCW (reset)

References

1 N.O. Reed contacts snap action



9007C84B2	9007C84A2	9007C84N2	9007C84C

1 N.C. Reed contacts snap action



9007C86B2	9007C86A2	9007C86N2	9007C86C

Weight kg (lb)	0.568 (1.25)	0.568 (1.25)	0.568 (1.25)	0.568 (1.25)
----------------	--------------	--------------	--------------	--------------

Contact operation	
-------------------	--

Characteristics (nominal operating data)

Switch actuation	By 30° cam			
Type of actuation				
Pre-travel	13°	7°	13°	45°
Total travel	90°			
Differential	7°	4°	7°	-
Reverse overtravel	90°	90°	90°	-
Mechanical durability in millions of operating cycles	10			
Operating torque force 1 pole & 2 pole	4 lb-in (17.8 N.m)		25 oz-in (0.18 N.m)	3 lb-in (0.34 N.m)
Terminal wire sizes (Cabling/Screw Clamp)	1 or 2, 12-22AWG (2.05 mm ² - 0.644 mm ²) wires maximum			
Repeatability (linear travel of cam)	0.15 mm (± 0.006")	0.076 mm (± 0.003")	0.15 mm (± 0.006")	0.15 mm (± 0.006")
Cable entry	1/2-14 NPT standard, optional M20 x 1.5 mm for ISO cable gland			

(1) Lever arm type must be ordered separately from pages 32 to 37.



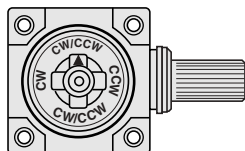

(2) These devices are factory set to operate the contacts in **both** the CW and CCW directions. **Mode of operation** is field convertible to CW only or CCW only. **To order factory converted devices** - for CCW only operation, change the "2" at the end of the type number to "1" (Example : C54B2 becomes C54B1) - for CW only operation, delete the "2" at the end of the type number (Example C54B2 becomes C54B).

Mode change of lever arm is easily convertible to clockwise, or both. Simply point the arrow to the letters representing the desired direction - CW, CCW, or CW/CCW.







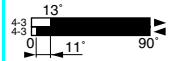
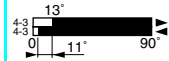
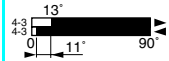
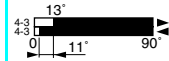
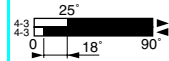

Limit switches

9007C Heavy Duty Industrial
Standard plug-in body metal, Reed contacts
Conforming to NEMA 6P and UL 508

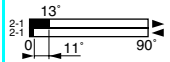
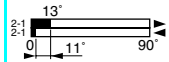
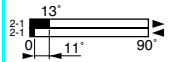
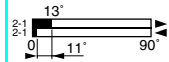
Type of head Standard plug-in body type	Flexible operator (wobble stick)				
					

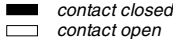
Type of operator	Universal (1)	Wobble stick DELRIN extension (1)	Wobble stick wire extension (1)	Wobble stick coil spring extension (1)	Cat whisker
-------------------------	---------------	-----------------------------------	---------------------------------	--	-------------

References					
1 N.O. Reed contacts snap action 	9007C84JKC 	9007C84J 	9007C84K 	9007C84KC 	9007C84L 
1 N.C. Reed contacts snap action 	9007C86JKC 	9007C86J 	9007C86K 	9007C86KC 	9007C86L 
Weight kg (lb)	0.568 (1.25)	0.568 (1.25)	0.568 (1.25)	0.568 (1.25)	0.568 (1.25)
Contact operation					

Characteristics (nominal operating data)	
Switch actuation	By any moving object in any direction
Type of actuation	
Pre-travel	13° (any direction) 25°
Total travel	90°
Differential	11° 18°
Reverse overtravel	—
Mechanical durability in millions of operating cycles	10
Operating torque/force 1 pole & 2 pole	3 lb-in (0.34 N.m) 7 oz-in (0.05 N.m)
Terminal wire sizes (Cabling/Screw Clamp)	1 or 2, 12-22AWG (2.05 mm ² - 0.644 mm ²) wires maximum
Repeatability (linear travel of cam)	—
Cable entry	1/2-14 NPT standard, optional M20 x 1.5 mm for ISO cable gland

(1) Wobble stick extensions are available separately for the universal head or as replacements for complete devices (see page 31)
Acceptable wire sizes : 12-22 AWG Recommended,
Terminal clamp torque : 7 lb-in (0.80 N.m).

Limit switches

9007C Heavy Duty Industrial
Compact plug-in body metal
Conforming to NEMA 6P and UL 508

Type of head Compact plug-in body type	Side Plunger (fixing by the body)
---	-----------------------------------



Type of operator	Side roller plunger spring return vertical roller (1)	Side push rod plunger spring return	Side push rod plunger adjustable (2) spring return	Side push rod plunger maintained contact
------------------	---	--	--	---

References

1 N.O. 1 N.C. snap action 	9007C52F 	9007C52G 	9007C52GD 	9007C52H
-------------------------------	---------------------	---------------------	----------------------	---------------------

Weight kg (lb)	0.456 (1.01)	0.445 (0.98)	0.422 (0.93)	0.568 (1.25)
----------------	--------------	--------------	--------------	--------------

Contact operation				
-------------------	--	--	--	--

Characteristics (nominal operating data)

Switch actuation	On end		
Type of actuation			
Pre-travel	2 mm (0.08")		3.6 mm (0.14")
Pre-travel two Stage	First stage	2 mm (0.08")	
	First stage to second stage	0.5 mm (0.02")	
Total travel	6.3 mm (0.25")		6.3 mm (0.25")
Differential	0.8 mm (0.03")		-
Reverse overtravel	-		-
Mechanical durability in millions of operating cycles	10		
Minimum force or torque 1 pole & 2 pole	4 lb (17.8 N)		7 lb (31.1 N)
Terminal wire sizes (Cabling/Screw Clamp)	1 or 2, 12-22AWG (2.05 mm ² - 0.644 mm ²) wires maximum		
Repeatability (linear travel of cam)	0.03 mm (0.001")		-
Cable entry	1/2-14 NPT standard, optional M20 x 1.5 mm for ISO cable gland		



(1) Can be converted to horizontal roller type in the field. To order horizontal roller version add the letter **H** at the end of the equivalent vertical roller version type.
(2) To lock the nut in the desired position, crimp the slot near the bottom of the nut.

Limit switches

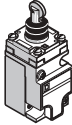
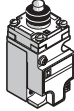
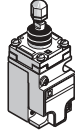
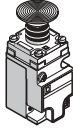
9007C Heavy Duty Industrial
Compact plug-in body metal
Conforming to NEMA 6P and UL 508

Type of head Compact plug-in body type	Top Plunger (fixing by the body)			
				

Type of operator	Top roller plunger spring return	Top push rod plunger spring return	Top push rod plunger adjustable (1) spring return	Palm operated (2)
-------------------------	----------------------------------	------------------------------------	---	-------------------

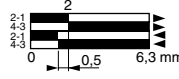
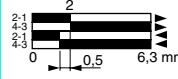
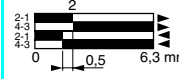
References				
1 N.O. 1 N.C. snap action	9007C52D	9007C52E	9007C52ED	9007C52R (2)
				

Weight kg (lb)	0.169 (0.43)	0.169 (0.43)	0.422 (0,93)	0.568 (1.25)
-----------------------	--------------	--------------	--------------	--------------

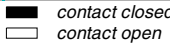
Contact operation				
--------------------------	---	--	--	--

Characteristics (nominal operating data)		
Switch actuation	On end	
Type of actuation		
Pre-travel	2 mm (0.08")	
Pre-travel two Stage	First stage	2 mm (0.08")
	First stage to second stage	0.03 mm (0.01")
Total travel	6.3 mm (0.25")	
Differential	0.5 mm (0.02")	
Reverse overtravel		
Mechanical durability in millions of operating cycles	10	
Minimum force or torque 1 pole & 2 pole	3 lb (13.3 N)	
Terminal wire sizes (Cabling/Screw Clamp)	1 or 2, 12-22AWG (2.05 mm ² - 0.644 mm ²) wires maximum	
Repeatability (linear travel of cam)	0.03 mm (0.001")	
Cable entry	1/2-14 NPT standard, optional M20 x 1.5 mm for ISO cable gland	

(1) To lock the nut in the desired position, crimp the slot near the bottom of the nut.

(2) Does not include mushroom button. Must be ordered separately see page 31.

Limit switches

9007C Heavy Duty Industrial
Compact plug-in body metal
Conforming to NEMA 6P and UL 508

Type of head Compact plug-in body type	Rotary (lever arm type) (1)
---	-----------------------------



Type of operator	Standard pre-travel spring return	Low differential spring return	Light operating torque spring return	Maintained contact
Type of direction	CW & CCW (2)	CW & CCW (2)	CW & CCW (2)	CW (trip) CCW (reset)

References

1 N.O. 1 N.C. snap action



	9007C52B2	9007C52A2	9007C52N2	9007C52C

Weight kg (lb)	0.481 (1.06)	0.481 (1.06)	0.481 (1.06)	0.481 (1.06)
----------------	--------------	--------------	--------------	--------------

Contact operation	contact closed contact open
-------------------	--------------------------------

Characteristics (nominal operating data)

Switch actuation	By 30° cam
------------------	------------



Pre-travel	10°	5°	10°	45°
Pre-travel two Stage				
- First stage	10°	5°	10°	-
- First stage to second stage	2,5°	1,5°	2,5°	-
Total travel	90°	90°	90°	90°
Differential	4°	2°	4°	-
Reverse overtravel	90°	90°	90°	-
Mechanical durability in millions of operating cycles	10			
Operating torque/force 1 pole & 2 pole	4 lb-in (0.45 N.m)		25 oz-in (0.18 N.m)	3 lb-in (0.34 N.m)
Terminal wire sizes (Cabling/Screw Clamp)	1 or 2, 12-22AWG (2.05 mm ² - 0.644 mm ²) wires maximum			
Repeatability (linear travel of cam)	0.05 mm (± 0.002")	0.03 mm (± 0.001")	0.05 mm (± 0.002")	0.05 mm (± 0.002")
Cable entry	1/2-14 NPT standard, optional M20 x 1.5 mm for ISO cable gland			

(1) Lever arm type must be ordered separately from pages 32 to 37.

(2) These devices are factory set to operate the contacts in **both** the CW and CCW directions. **Mode of operation** is field convertible to CW only or CCW only.



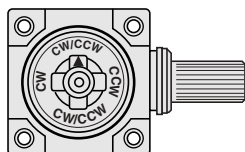

To order factory converted devices - for CCW only operation, change the "2" at the end of the type number to "1" (Example : C52B2 becomes C52B1) - for CW only operation, delete the "2" at the end of the type number (Example C52B2 becomes C52B).

Mode change of lever arm is easily convertible to clockwise, or both. Simply point the arrow to the letters representing the desired direction - CW, CCW, or CW/CCW.

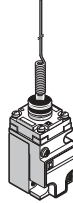
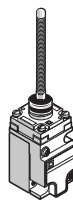

Limit switches

9007C Heavy Duty Industrial
Compact plug-in body metal
Conforming to NEMA 6P and UL 508

Type of head Compact plug-in body type	Flexible operator (wobble stick)				
					

Type of operator	Universal (1)	Wobble stick DELRIN extension (1)	Wobble stick wire extension (1)	Wobble stick coil spring extension (1)	Cat whisker
-------------------------	---------------	-----------------------------------	---------------------------------	--	-------------

References

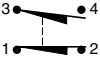
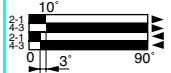
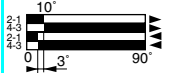
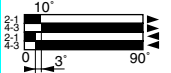
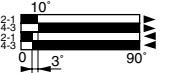
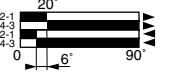
1 N.O. 1 N.C. 	9007C52JKC 	9007C52J 	9007C52K 	9007C52KC 	9007C52L 
---	--	--	---	---	--

Weight kg (lb)	0.468 (1.03)	0.568 (1.25)	0.540 (1.19)	0.568 (1.25)	0.468 (1.03)
-----------------------	--------------	--------------	--------------	--------------	--------------

Contact operation					
--------------------------	---	--	--	--	--

Characteristics (nominal operating data)

Switch actuation	By any moving				
-------------------------	---------------	--	--	--	--

Type of actuation					
--------------------------	--	--	--	--	--

Pre-travel	10° (any direction)	20°
Pre-travel two Stage		
- First stage	10° (any direction)	20°
- First stage to second stage	4°	5°
Total travel	90°	
Differential	3°	6°
Reverse overtravel	-	
Mechanical durability in millions of operating cycles	10	
Operating torque/force 1 pole & 2 pole	3 lb-in (0.34 N.m)	7 oz-in (0.05 N.m)
Terminal wire sizes (Cabling/Screw Clamp)	1 or 2, 12-22AWG (2.05 mm ² - 0.644 mm ²) wires maximum	
Repeatability (linear travel of cam)	-	
Cable entry	1/2-14 NPT standard, optional M20 x 1.5 mm for ISO cable gland	

(1) Wobble stick extensions are available separately for the universal head or as replacements for complete devices (see page 31).

Limit switches

9007C Heavy Duty Industrial Plug-in body metal Factory modifications (Forms)



S9

Rotary head shown
with S9 option

Special features and modifications

Special features do not apply to 9007CR unless noted. Not field installable, except where noted.

Shaft equipped with hub for mounting larger diameter lever used with 9007T/FT limit switches

Any rotary lever arm 9007C, CF or CR switch can be furnished with an optional shaft and hub combination which will accept the lever arms normally used with 9007T and FT limit switches. To order, add S9 as suffix to the device number. For example, to order a 9007C54B2 with this modification, order as a 9007C54B2S9. For details about switches and lever arms that can be furnished with this modification, see the appropriate Product Catalog Square D Digest.

Description	Suffix to be added to the device reference	Weight kg (lb)
Optional hub for 9007T/FT levers (not shown in this catalog)	S9	0.018 (0.04)

Hub only: can be field installed on rotary shaft, see accessories page 23

Addition of LED pilot light (1)

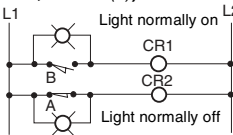
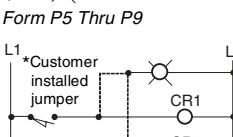
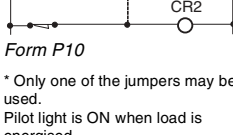
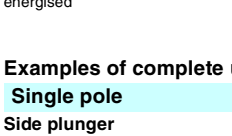
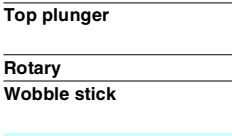
Description	Suffix to be added to the device reference	Weight kg (lb)
LED Pilot light, 24 to 120 V AC or DC on plug-in type switch (9007C52, C54, C62, C66, C68 or (2))	P5 (2)	0.57 (1.25)
	P6 (2)	0.57 (1.25)
	P7	0.57 (1.25)
	P8 (3)	0.57 (1.25)
	P9 (3)	0.57 (1.25)
	P10 (4)	0.57 (1.25)

Form P5 Thru P9

Form P10

* Only one of the jumpers may be used.
Pilot light is ON when load is energised

(1) Bleeder circuit must be added to ensure PLC compatibility.
(2) 9007C84 and C86 are available with P5 or P6 pilot lights only.
(3) 9007C62, C66 or C68 only.
(4) 9007C54 only. Not available with prewired receptacles.

Examples of complete units with pilot lights in standard plug-in body type

Single pole		
Side plunger	9007 C54FP6	0.57 (1.25)
Top plunger	9007 C54DP6	0.57 (1.25)
	9007 C54EP6	0.57 (1.25)
Rotary	9007 C54B2P6	0.57 (1.25)
Wobble stick	9007 C54LP6	0.57 (1.25)
	9007 C54JP6	0.57 (1.25)
Two poles		
Side plunger	9007 C62FP6	0.57 (1.25)
Top plunger	9007 C62DP6	0.57 (1.25)
	9007 C62EP6	0.57 (1.25)
Rotary	9007 C62B2P6	0.57 (1.25)
Wobble stick	9007 C62LP6	0.57 (1.25)
	9007 C62JP6	0.57 (1.25)

Limit switches

9007C Heavy Duty Industrial Plug-in body metal Factory modifications (Forms)

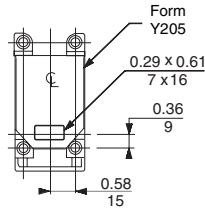

Y2051

Special features and modifications (continued)

Special features do not apply to 9007CR unless noted. Not field installable, except where noted.

Manifold mounting

Description	Suffix to be added to the device reference	Weight kg (lb)
Manifold mounting available on standard and compact types. Replaces existing type B installations if new hole is drilled to match knockout. Supersedes type C with form Y205. Receptacle is furnished with a wiring hole and a gasket in the base.	Y2051	0.57 (1.25)
Special chemical resistant coating (includes fluorocarbon [VITON] seals - Y140, and stainless steel head and body screws) (1)	L3	0.57 (1.25)
Low temperature – lever types only: limit switch will operate in an ambient temperature range of - 40 °F to 185 °F (standard limit switch ambient temperature range is - 20 °F to 185 °F). Minimum temperature is based on the absence of freezing moisture or water.	Y128	0.57 (1.25)
Fluorocarbon (VITON) gaskets and seals (1)		
Substitution of fluorocarbon (VITON) gaskets and seals on:		
Lever arm type, standard box (shaft seals on lever arm types are fluorocarbon (VITON) as standard)	Y140	0.57 (1.25)
Lever arm type, compact box (shaft seals on lever arm types are fluorocarbon (VITON) as standard)	Y140	0.57 (1.25)
Plunger type, standard box	Y140	0.57 (1.25)
Plunger type, compact box	Y140	0.57 (1.25)
Substitution of fluorocarbon (VITON) boot only on plunger type switches	Y1401	0.57 (1.25)

(1) Fluorocarbon (VITON) has been shown to resist sunlight aging problems.

Mini and micro connectors, ISO M20 (Form M11)

To order 9007C with ISO M 20 thread add the suffix **M11** to the device number.

Examples of complete unit references with ISO M20 thread in standard plug-in body type

Type of head	Reference	Weight kg (lb)
Single pole		
Side plunger	9007 C54FM11	0.57 (1.25)
Top plunger	9007 C54DM11	0.57 (1.25)
	9007 C54EM11	0.57 (1.25)
Rotary	9007 C54B2M11	0.57 (1.25)
Wobble stick	9007 C54LM11	0.57 (1.25)
	9007 C54JM11	0.57 (1.25)
Two poles		
Side plunger	9007 C62FM11	0.57 (1.25)
Top plunger	9007 C62DM11	0.57 (1.25)
	9007 C62EM11	0.57 (1.25)
Rotary	9007 C62B2M11	0.57 (1.25)
Wobble stick	9007 C62LM11	0.57 (1.25)
	9007 C62JM11	0.57 (1.25)

Limit switches

9007C Heavy Duty Industrial

Plug-in body metal

Factory modifications (Forms)



Y190●

Standard body shown with Y190● option

Special features and modifications (continued)

Special features do not apply to 9007CR unless noted. Not field installable, except where noted.

Pre-wired receptacle (1) (2)

Description	For use	Suffix to be added to the device reference	Weight kg (lb)
Plug-in limit switch furnished with pre-wired mini 5 pin Brad Harrison male connector			
Single pole	For use with Brad Harrison female portable plug No.41306, 41307 or 41308 (or equal).	Y1901	0.60 (1.33)
	Same as Y1901 but with different wire color coding	Y1905	0.60 (1.33)
Tamper proof screws in complete switch only			
Single pole	Same as Y1901 but with tamper proof screws on head and body	Y1903	0.60 (1.33)
	Similar to Y1905 except for double pole device	Y19013	0.60 (1.33)

(1) Plug and cable assemblies: see accessories page 23

(2) Not available with P10 or for Hazardous location switches

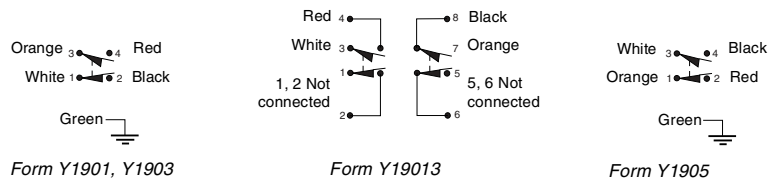

Examples of complete unit references with mini or micro connectors in standard plug-in body type

Type of head	Reference	Weight kg (lb)
Single pole, 5 pin mini connector (7/8"-16 UN-2A thread)		
Side plunger	9007 C54FY1901	0.57 (1.25)
Top plunger	9007 C54DY1901	0.57 (1.25)
	9007 C54EY1901	0.57 (1.25)
Rotary	9007 C54B2Y1901	0.57 (1.25)
Wobble stick	9007 C54LY1901	0.57 (1.25)
	9007 C54JY1901	0.57 (1.25)
Two poles, 9 pin mini connector (1-2/8"-16 UN-2A thread)		
Side plunger	9007 C62FY19016	0.57 (1.25)
Top plunger	9007 C62DY19016	0.57 (1.25)
	9007 C62EY19016	0.57 (1.25)
Rotary	9007 C62B2Y19016	0.57 (1.25)
Wobble stick	9007 C62LY19016	0.57 (1.25)
	9007 C62JY19016	0.57 (1.25)
Single pole, 5 pin micro single key (M12 x 1 thread)		
Side plunger	9007 C62FY1912	0.57 (1.25)
Top plunger	9007 C54DY1912	0.57 (1.25)
	9007 C54EY1912	0.57 (1.25)
Rotary	9007 C54B2Y1912	0.57 (1.25)
Wobble stick	9007 C54LY1912	0.57 (1.25)
	9007 C54JY1912	0.57 (1.25)
Single pole, 5 pin micro connector two keys (1/2"-20 UNF-2A thread)		
Side plunger	9007 C54FY19019	0.57 (1.25)
Top plunger	9007 C54DY19019	0.57 (1.25)
	9007 C54EY19019	0.57 (1.25)
Rotary	9007 C54B2Y19019	0.57 (1.25)
Wobble stick	9007 C54LY19019	0.57 (1.25)
	9007 C54JY19019	0.57 (1.25)

Limit switches

9007C Heavy Duty Industrial Plug-in body metal Factory modifications (Forms)



Y18●●

Terminal base shown
with Y18●● option

Special features and modifications (continued)

Special features do not apply to 9007CR unless noted. Not field installable, except where noted.

Potted limit (position) switch or plug-in receptacle only (1)

Description (2)	Suffix to be added to the device reference	Weight kg (lb)
With individual wires		
Single pole With five #16 wires five feet long	Y1841	0.59 (1.30)
Two pole With nine #16 wires five feet long	Y1842	0.60 (1.32)

With STOWA cord		
Single pole With five conductor #16 STOWA cord eight feet long	Y1851	1.30 (2.88)
Single pole Same as Y1851 but with different wire color coding	Y1855	1.30 (2.88)
Two pole With nine conductor #16 STOWA cord eight feet long	Y1852	1.31 (2.90)
Two pole Same as Y1852 but with different wire color coding	Y1856	1.31 (2.90)

Tamper proof Screws - Complete Switch Only

With individual wires		
Same as Y1841 but with tamper proof screws on head and body	Y1843	0.59 (1.30)
Same as Y1842 but with tamper proof screws on head and body	Y1844	0.60 (1.32)

With STOWA cord		
Same as Y1851 but with tamper proof screws on head and body	Y1853	1.30 (2.88)
Same as Y1852 but with tamper proof screws on head and body	Y1854	1.30 (2.88)
Same as Y1855 but with tamper proof screws on head and body	Y1857	1.31 (2.90)
Same as Y1856 but with tamper proof screws on head and body	Y1858	1.31 (2.90)

(1) Not for 9007CR Hazardous location devices

(2) Wire entry completely sealed with epoxy resin.

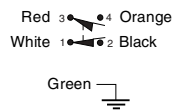

Forms Y1851 and Y1853

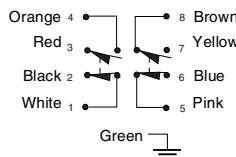

Forms Y1852 and Y1854



Forms Y1855 and Y1857

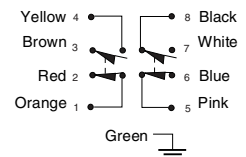

Forms Y1856 and Y1858

Dust boot (Protection against abrasive dusts, dirt, grit and sand)

Description	Suffix to be added to the device reference	Weight kg (lb)
Lever type limit switch furnished with a boot around the shaft	On all 9007C and 9007CR lever type switches Y33	0.01 (0.01)

Dust boot only: see accessories page 23

Limit switches

9007C Heavy Duty Industrial Plug-in body metal Factory modifications (Forms)

Special features and modifications (continued)

Special features do not apply to 9007CR unless noted. Not field installable, except where noted.

Optional shafts

Description	Suffix to be added to the device reference	Weight kg (lb)
Optional shaft (7.8 mm (0.306") diameter): To accommodate lever arms from the obsolete Denison C limit switches. Available on all 9007C, CF, or CR limit switches	Y247	0.57 (1.25)
Optional shaft (7.1 mm (0.28") diameter): Available on all 9007C, CF, or CR limit switches	Y249	0.57 (1.25)

Switch with adapter plate

Description	Suffix to be added to the device reference	Weight kg (lb)
Switch with adapter plate permitting substitution of any 9007C switch with standard body for any type T switch with style B base plate	Y147	–

Direct acting contacts / Positive opening contacts ☹ Y1561

One pole, normally closed, slow make-slow break, direct acting contact mechanism substituted for standard snap switch on 9007C52, C54 and CR53 devices.

This mechanism was designed for use in emergency overtravel applications. The movable contact of this basic switch unit is acted upon directly by the actuating mechanism of the limit switch and is not dependent upon the force exerted by a snap switch blade or spring to open the circuit. Because these contacts are slow make-slow break, they are best suited for applications where they are not actuated during normal operation, but only if abnormal overtravel is encountered.

Electrical contact ratings

AC - NEMA A600 maximum current - 35 % power factor						DC maximum current			
Make			Break		Continuous carrying	Make or break			Continuous carrying
Volts	Amps	VA	Amps	VA	Amps	Volts	Amps	VA	Amps
120	60	7200	6	720	10	125	1.1/0.55 (1)	138/69 (1)	5/2.5 (1)
240	30	7200	3	720	10	–	–	–	–
480	15	7200	1.5	720	10	250	0.27	67.5	2.5
600	12	7200	1.2	720	10	600	0.10	60	2.5

(1) 9007C52 compact unit ratings at 125 VDC - same ratings as 9007C54 and 9007CR53 at other voltages.

Description	Suffix to be added to the device reference	Weight kg (lb)
Direct acting contact/positive opening contact block (slow break single pole only)	Y1561	0.566 (1.25)

Limit switches

9007C Heavy Duty Industrial

Plug-in body metal

Accessories

Accessories

Hub only

Description	Reference	Weight kg (lb)
Hub can be field installed on any 9007C lever type switch increases shaft diameter from 0.375" (9.53 mm) to 0.749" (19 mm)	9007S9	0.02 (0.04)

Dust boot only

Description	Reference	Weight kg (lb)
Dust boot can be field installed on any 9007C and CR lever type switch	9007BT3	0.01 (0.01)

Conduit seal insert (field instable)

Description	Reference	Weight kg (lb)
Conduit seal fits in conduit entrance and excludes liquids		
5 hole seal	31032-488-01	0.01 (0.02)
9 hole seal	31032-815-01	0.01 (0.02)

Plug and cable assemblies

Description	Reference	Weight kg (lb)
5 pin mini connecting cables to fit switches with form Y190●●		
Plug and 3' (0.91 m) cable	BH20-5-3	—
Plug and 6' (5.49 m) cable	BH20-5-6	—
Plug and 12' (10.97 m) cable	BH20-5-12	—

Adapter - Field installable

Description	Reference	Weight kg (lb)
Adapter plate kit only Plate plus mounting screws for substitution of any 9007C switch with standard box for any 9007T switch with style B base plate	9007BT1	0.23 (0.50)
Adapter plate to allow direct substitution of any 9007C plunger switches for 9007B plug-in plunger switches - use only if there is a problem in lining up cam tracks		
Standard body type	9007CT10 (1)	0.13 (0.28)
Compact body type	9007CT13 (2)	0.01 (0.20)
Adapter plate kit permitting direct substitution of any 9007C lever arm switch with standard box for any 9007AW lever arm switch	9007CT11	0.23 (0.50)
20 mm conduit connection adapter male 0.5" (12.7 mm) NPT on one end, female 0.787" (20 mm) on other end	9007CT12	0.01 (0.20)

(1) Dimensions: 0.22" (5.6 mm) x 2.94" (75 mm) x 1.54" (39 mm)

(2) Dimensions: 0.22" (5.6 mm) x 2.07" (53 mm) x 1.54" (39 mm)

Limit switches

9007C Heavy Duty Industrial
Standard plug-in body metal
Conforming to NEMA 6P and UL 508

Side Plunger

9007C●●F

9007C●●G

9007C●●GD

9007C●●H

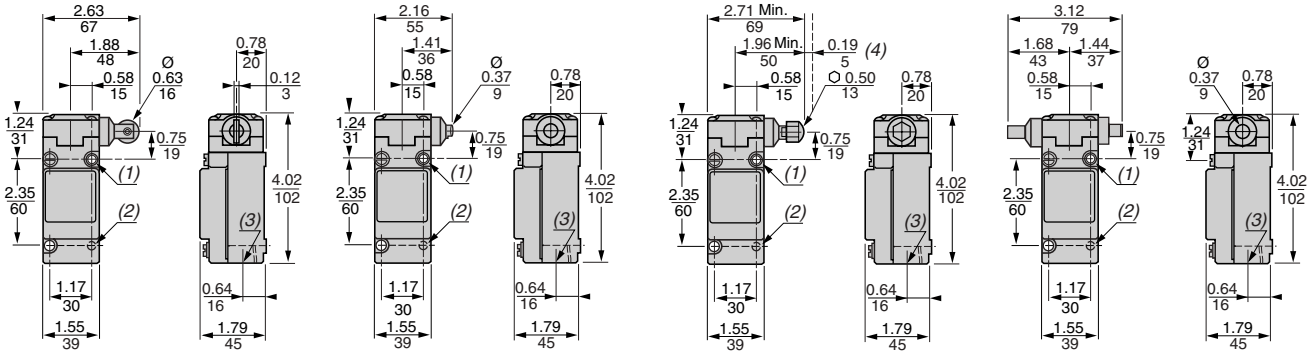

Dual dimensions : $\frac{\text{inches}}{\text{mm}}$

- (1) 2 x 0.20/5 x 0.22/6 HLS.
- (2) 2 x 10-24 Tapped HLS Back Mtg 0.29/7 DP.
- (3) 1/2 14 NPT.
- (4) Adjustable.

Top Plunger

9007C●●D

9007C●●E

9007C●●ED

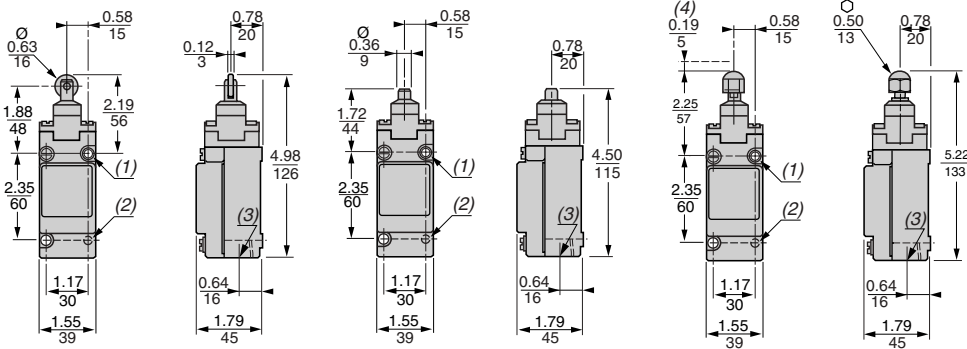

Dual dimensions : $\frac{\text{inches}}{\text{mm}}$

- (1) 2 x 0.20/5 x 0.22/6 HLS.
- (2) 2 x 10-24 Tapped HLS Back Mtg 0.29/7 DP.
- (3) 1/2 14 NPT.
- (4) Adjustable.

Limit switches

9007C Heavy Duty Industrial
Standard plug-in body metal
Conforming to NEMA 6P and UL 508

Rotary

9007C A, B, C, N, T5, T10

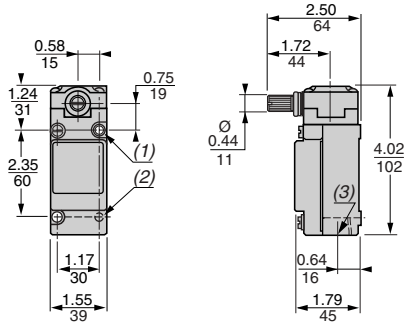

Dual dimensions : $\frac{\text{inches}}{\text{mm}}$

- (1) 2 x 0.20/5 x 0.22/6 HLS.
- (2) 2 x 10-24 Tapped HLS Back Mtg 0.29/7 DP.
- (3) 1/2 14 NPT.

Wobble stick

9007C JKC

9007C J

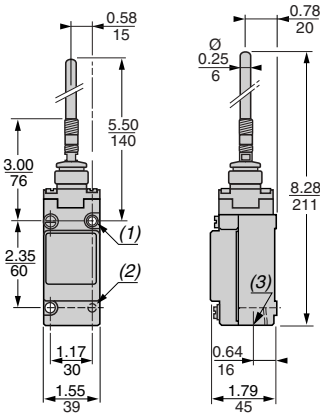
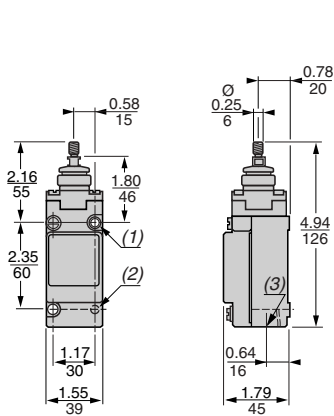

9007C K

9007C KC

9007C L

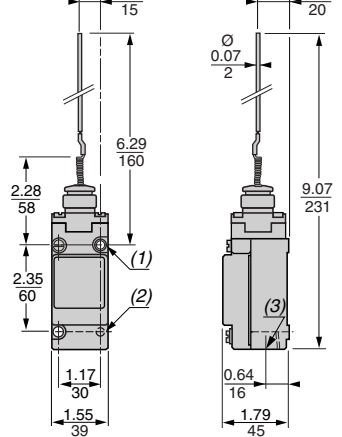
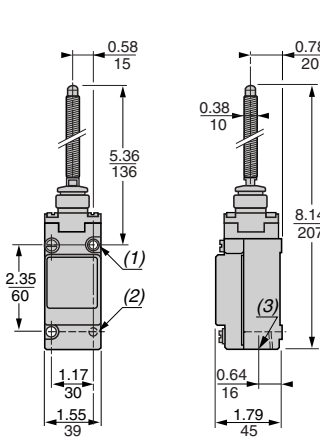
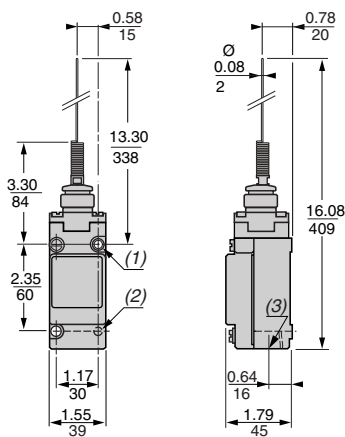

Dual dimensions : $\frac{\text{inches}}{\text{mm}}$

- (1) 2 x 0.20/5 x 0.22/6 HLS.
- (2) 2 x 10-24 Tapped HLS Back Mtg 0.29/7 DP.
- (3) 1/2 14 NPT.

Limit switches

9007C Heavy Duty Industrial
Compact plug-in body metal
Conforming to NEMA 6P and UL 508

Side Plunger

9007C52F

9007C52G

9007C52GD

9007C52H

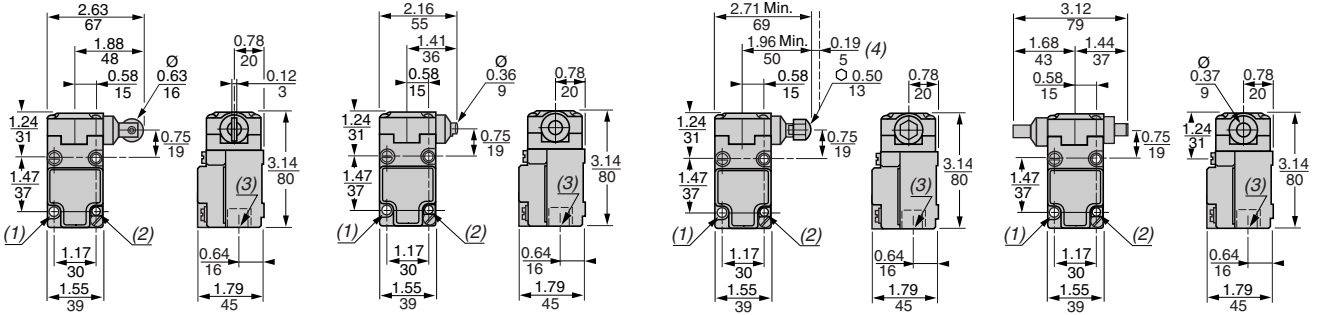

Dual dimensions : $\frac{\text{inches}}{\text{mm}}$

- (1) 2 x 0.20/5 HLS.
- (2) 2 x 10-24 Tapped HLS Back Mtg 0.20/5 DP.
- (3) 1/2 14 NPT.
- (4) Adjustable.

Top Plunger

9007C52D

9007C52E

9007C52ED

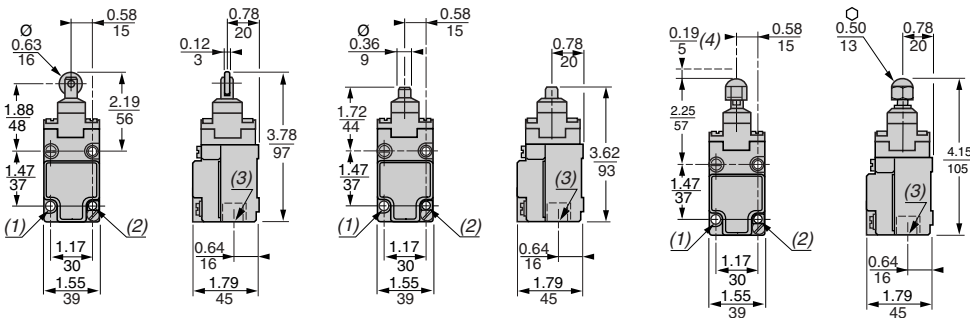

Dual dimensions : $\frac{\text{inches}}{\text{mm}}$

- (1) 2 x 0.20/5 HLS.
- (2) 2 x 10-24 Tapped HLS Back Mtg 0.20/5 DP.
- (3) 1/2 14 NPT.
- (4) Adjustable.

Limit switches

9007C Heavy Duty Industrial
Compact plug-in body metal
Conforming to NEMA 6P and UL 508

Rotary

9007C52●● A, B, C, N, T5, T10

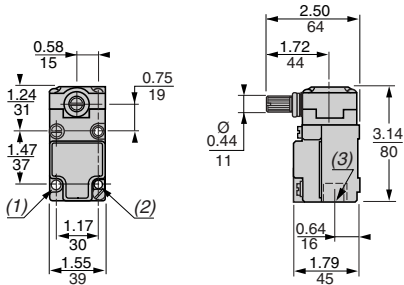

Dual dimensions : $\frac{\text{inches}}{\text{mm}}$

- (1) 2 x 0.20/5 x 0.22/6 HLS.
- (2) 2 x 10-24 Tapped HLS Back Mtg 0.29/7 DP.
- (3) 1/2 14 NPT.

Wobble stick

9007C52JKC

9007C52J

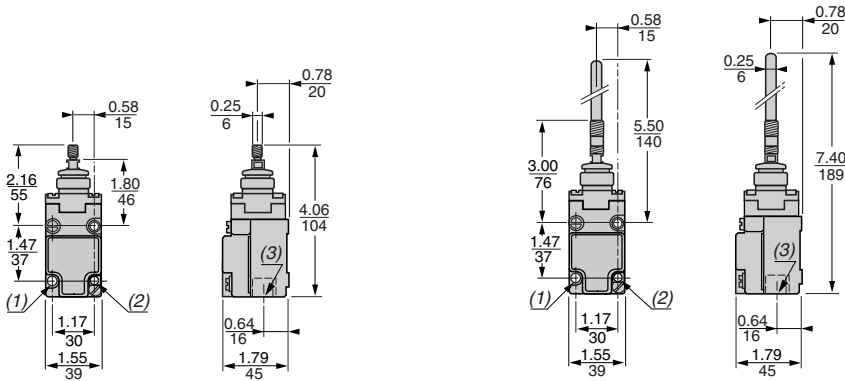

9007C52K

9007C52KC

9007C52L

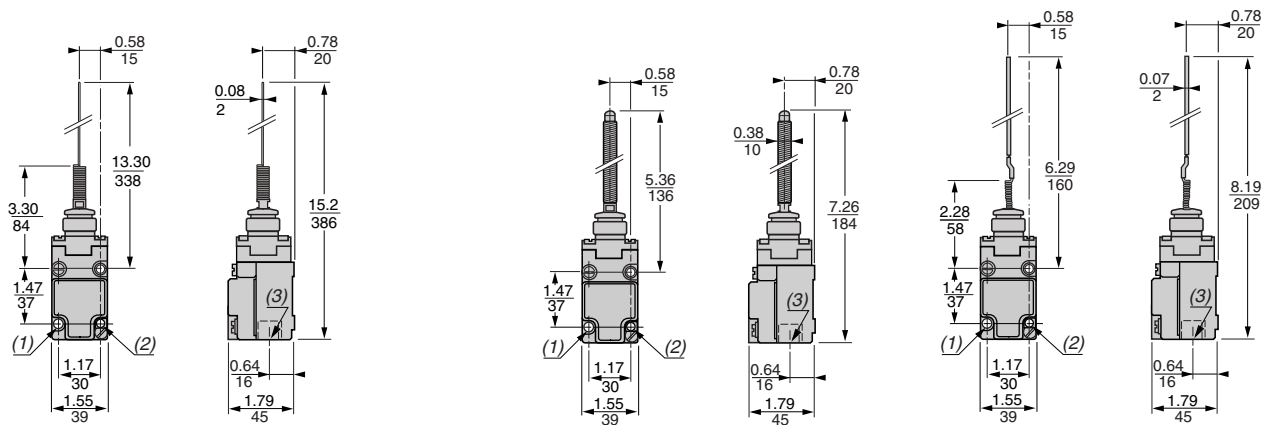

Dual dimensions : $\frac{\text{inches}}{\text{mm}}$

- (1) 2 x 0.20/5 x 0.22/6 HLS.
- (2) 2 x 10-24 Tapped HLS Back Mtg 0.29/7 DP.
- (3) 1/2 14 NPT.

Limit switches

9007C Heavy Duty Industrial

Plug-in body metal

Adaptable sub-assemblies

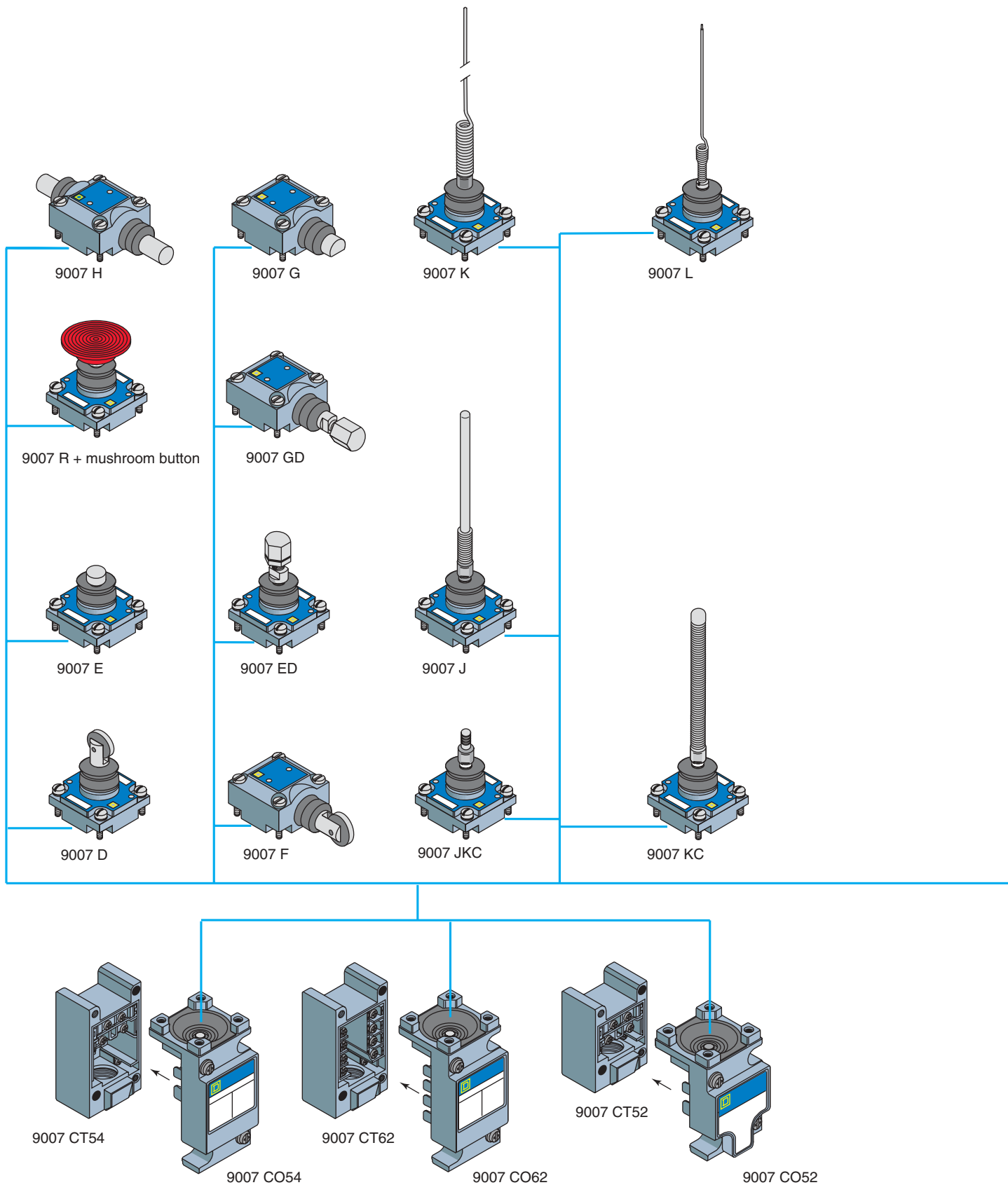

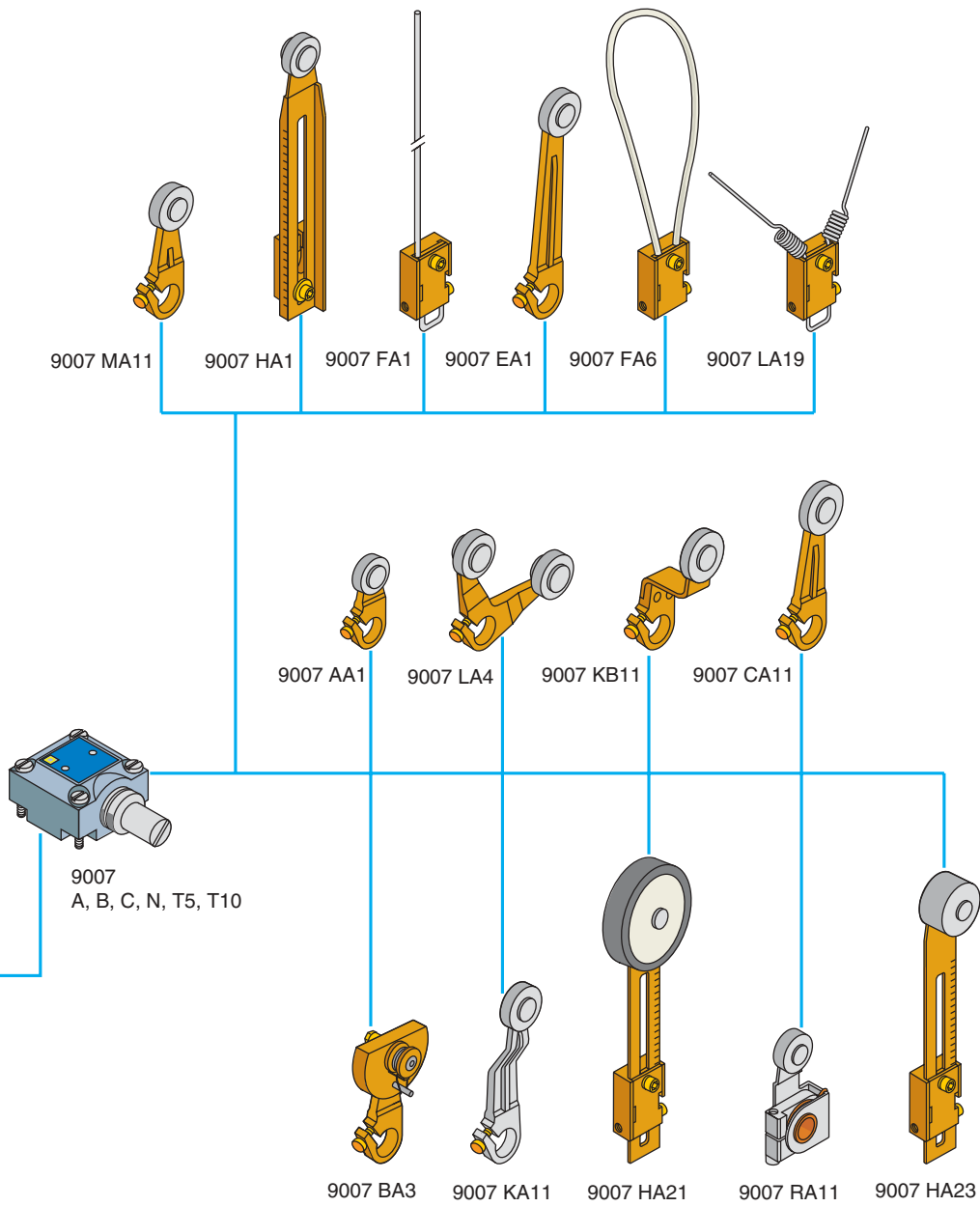

Limit switches

9007C Heavy Duty Industrial
Plug-in body metal
Adaptable sub-assemblies

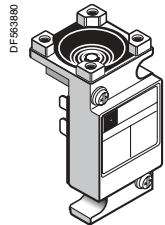

9007CO54

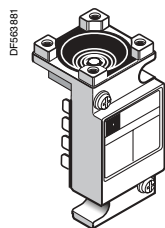

9007CO62

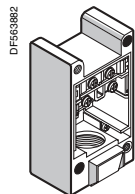

9007CT54

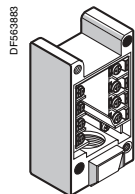

9007CT62

Body with contacts for plunger or rotary heads

Plug-in Unit (Top) with contacts

Type	Type of contact	Scheme	Reference	Weight kg (lb)
For standard plug-in body type	Single pole		9007CO54	0.19 (0.42)
	Two pole		9007CO62	0.20 (0.44)
	Two stage		9007CO66	0.23 (0.50)
	Neutral position		9007CO68	0.20 (0.45)
For compact plug-in body type	Single pole		9007CO52	0.18 (0.40)

Plug-in Receptacle (Base) with screw terminals (1)

Type	Type of contact	Scheme	Reference	Weight kg (lb)
For standard plug-in body type	Single pole		9007CT54	0.22 (0.48)
	Two pole		9007CT62	0.22 (0.48)
	Neutral position		9007CT62	0.22 (0.48)
	Two stage		9007CT62	0.22 (0.48)
For compact plug-in body type	Reed switches, either N/O or N/C (2)		9007CT54	0.22 (0.48)
	Single pole		9007CT52	0.15 (0.34)

(1) Acceptable wire sizes : 12-22 AWG (2.05 mm²-0.644mm²). Recommended terminal clamp torque: 7 lb-in (0.80 N.m).

(2) Reed switches: plug-in switches less heads are not available as separate units. Order complete plug-in unit with a head. Example: 9007C084B2.

Limit switches

9007C Heavy Duty Industrial Plug-in body metal

Adaptable sub-assemblies

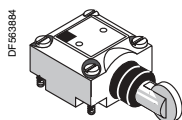

9007F

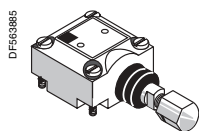

9007GD

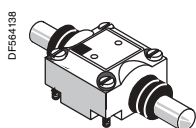

9007H

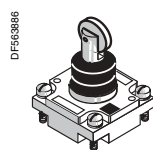

9007D

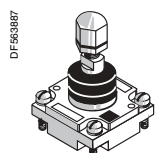

9007ED

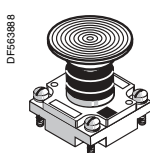

9007R + mushroom button

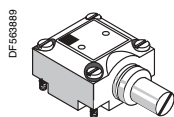

9007C

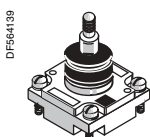

9007JKC

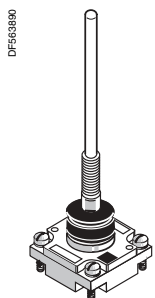

9007J

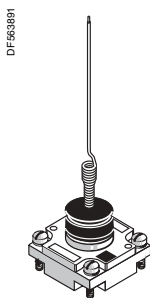

9007L

Heads for linear, rotary and multi-directional movements

Side plunger heads

Type of operator	Reference	Weight kg (lb)
Side roller plunger spring return vertical roller	9007F	0.16 (0.36)
Side push rod plunger spring return	9007G	0.15 (0.34)
Side push rod plunger adjustable spring return	9007GD	0.16 (0.36)
Side push rod plunger maintained contact	9007H	0.16 (0.36)

Top plunger heads

Type of operator	Reference	Weight kg (lb)
Top roller plunger spring return	9007D	0.12 (0.26)
Top push rod plunger spring return	9007E	0.11 (0.24)
Top push rod plunger adjustable spring return	9007ED	0.12 (0.27)
Palm operated turret head without mushroom button	9007R	0.13 (0.28)

Mushroom button see Accessories (below)

Rotary heads (without lever arm type)

Type of operator	Type of direction	Reference	Weight kg (lb)
Standard pre-travel spring return	CW & CCW	9007B	0.19 (0.41)
Low differential spring return	CW & CCW	9007A	0.19 (0.41)
Neutral position Standard pre-travel spring return	CW & CCW	9007T10	0.16 (0.36)
Neutral position Low differential spring return	CW & CCW	9007T5	0.16 (0.36)
Extra light operating torque spring return	CW & CCW	9007N	0.18 (0.40)
Maintained contact	CW (trip) CCW (reset)	9007C	0.19 (0.41)

Multi-directional head

Type of operator	Reference	Weight kg (lb)
Universal (1)	9007JKC	0.19 (0.41)
Wobble stick DELRIN extension (1)	9007J	0.20 (0.43)
Wobble stick wire extension (1)	9007K	0.26 (0.57)
Wobble stick coil spring extension (1)	9007KC	0.22 (0.48)
Cat whisker	9007L	0.17 (0.37)

Accessories

Description	Diameter Inches (mm)	Color	Reference	Weight kg (lb)
Mushroom button for palm operated turret head	1.38 (35)	Black	2358C6G3	0.03 (0.06)
		Red	2358C6G2	0.03 (0.06)
		Green	2358C6G6	0.03 (0.06)
		Yellow	2358C6G8	0.03 (0.06)
	2.25 (57.2)	Black	-	-
		Red	2358C22G3	0.05 (0.10)
		Green	2358C22G6	0.05 (0.10)
		Yellow	2358C22G8	0.05 (0.10)
Description (1)	Type of extension	Reference	Weight kg (lb)	
Wobble stick extensions for the universal head or as replacements for complete devices	DELRIN extension	9007WJ	0.01 (0.03)	
	Wire extension	9007WK	0.01 (0.02)	
	Coil Spring extension	9007WKC	0.02 (0.04)	

(1) Acceptable wire sizes : 12-22 AWG (2.05 mm²-0.644mm²). Recommended terminal clamp torque: 7 lb-in (0.80 N.m).

Limit switches

9007C Heavy Duty Industrial

Plug-in body metal

Lever arms for rotary heads

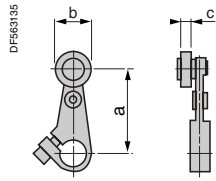

a : Length of lever Arm
b : Roller diameter
c : Roller width



9007AA1

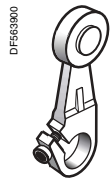

9007MA11

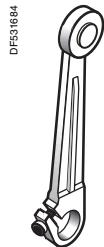

9007EA1

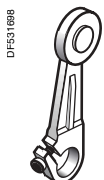

9007CA11

Cast zinc lever arms with standard roller

Lever arms with steel roller

Arm	Steel roller	Reference	Weight
Length (a) Inches (mm)	Diameter (b) Inches (mm)	Width (c) Inches (mm)	kg (lb)
0.88 (22)	0.63 (16)	0.25 (6.3)	9007AA1 0.02 (0.05)
		0.63 (16)	9007AA2 0.03 (0.07)
1.38 (35)	0.75 (19)	0.25 (6.3)	9007BA11 0.03 (0.07)
		0.63 (16)	9007BA12 0.05 (0.10)
1.5 (38)	0.63 (16)	0.25 (6.3)	9007BA1 0.03 (0.07)
		0.63 (16)	9007BA2 0.04 (0.08)
	0.75 (19)	0.25 (6.3)	9007MA11 0.03 (0.07)
		0.63 (16)	9007MA12 0.05 (0.11)
2 (51)	0.63 (16)	0.25 (6.3)	9007MA1 0.03 (0.06)
		0.63 (16)	9007MA2 0.05 (0.10)
	0.75 (19)	0.25 (6.3)	9007CA11 0.04 (0.08)
		0.63 (16)	9007CA12 0.05 (0.12)
2.5 (63.5)	0.63 (16)	0.25 (6.3)	9007CA1 0.04 (0.08)
		0.63 (16)	9007CA2 0.05 (0.10)
	0.75 (19)	0.25 (6.3)	9007DA11 0.05 (0.10)
		0.63 (16)	9007DA12 0.06 (0.13)
3 (76)	0.63 (16)	0.25 (6.3)	9007DA1 0.04 (0.08)
		0.63 (16)	9007DA2 0.05 (0.11)
	0.75 (19)	0.25 (6.3)	9007EA11 0.05 (0.10)
		0.63 (16)	9007EA12 0.06 (0.14)
0.63 (16)	0.25 (6.3)	9007EA1 0.04 (0.09)	
	0.63 (16)	9007EA2 0.06 (0.14)	

Lever arms with nylon roller

Arm	Nylon roller	Reference	Weight
Length (a) Inches (mm)	Diameter (b) Inches (mm)	Width (c) Inches (mm)	kg (lb)
0.88 (22)	0.63 (16)	0.25 (6.3)	9007AA8 0.02 (0.05)
		0.63 (16)	9007AA17 0.03 (0.07)
1.38 (35)	0.75 (19)	0.25 (6.3)	9007BA18 0.03 (0.07)
		0.63 (16)	9007BA8 0.05 (0.10)
	0.63 (16)	0.25 (6.3)	9007BA17 0.05 (0.11)
		1 (25.4)	0.25 (6.3)
1.5 (38)	0.63 (16)	0.63 (16)	9007BA13 0.05 (0.10)
		0.75 (19)	0.25 (6.3)
	0.63 (16)	0.25 (6.3)	9007MA18 0.03 (0.06)
		0.63 (16)	0.25 (6.3)
2 (51)	1 (25.4)	0.25 (6.3)	9007MA17 0.05 (0.10)
		0.63 (16)	9007MA4 0.05 (0.10)
	0.75 (19)	0.63 (16)	9007MA13 0.05 (0.12)
		0.63 (16)	0.25 (6.3)
2.5 (63.5)	0.63 (16)	0.25 (6.3)	9007CA18 0.05 (0.10)
		0.63 (16)	9007CA8 0.03 (0.06)
	1 (25.4)	0.63 (16)	9007CA17 0.03 (0.07)
		0.25 (6.3)	9007CA4 0.05 (0.12)
3 (76)	0.63 (16)	0.63 (16)	9007CA13 0.06 (0.14)
		0.75 (19)	0.25 (6.3)
	0.63 (16)	0.25 (6.3)	9007DA18 0.03 (0.07)
		0.63 (16)	0.25 (6.3)
1 (25.4)	0.63 (16)	0.63 (16)	9007DA17 0.06 (0.13)
		0.25 (6.3)	9007DA4 0.06 (0.14)
	0.63 (16)	0.63 (16)	9007DA13 0.07 (0.15)
		0.75 (19)	0.25 (6.3)
0.63 (16)	0.63 (16)	0.25 (6.3)	9007EA8 0.06 (0.14)
		0.63 (16)	9007EA17 0.07 (0.16)
	1 (25.4)	0.25 (6.3)	9007EA4 0.07 (0.15)
		0.63 (16)	9007EA13 0.08 (0.17)

Limit switches

9007C Heavy Duty Industrial

Plug-in body metal

Lever arms for rotary heads

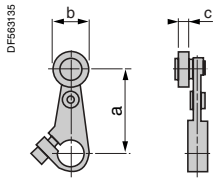

a : Length of lever Arm
b : Roller diameter
c : Roller width

Cast zinc lever arms with standard roller (continued)

Lever arms with ball bearing roller

Arm	Ball bearing roller		Reference	Weight
Length (a) Inches (mm)	Diameter (b) Inches (mm)	Width (c) Inches (mm)		kg (lb)
0.88 (22)	0.69 (17.5)	0.25 (6.3)	9007AA9	0.04 (0.09)
1.38 (35)	0.69 (17.5)	0.25 (6.3)	9007BA9	0.04 (0.09)
1.5 (38)	0.69 (17.5)	0.25 (6.3)	9007MA9	0.04 (0.09)
2 (51)	0.69 (17.5)	0.25 (6.3)	9007CA9	0.04 (0.09)
2.5 (63.5)	0.69 (17.5)	0.25 (6.3)	9007DA9	0.04 (0.09)
3 (76)	0.69 (17.5)	0.25 (6.3)	9007EA9	0.04 (0.09)

Lever arms with roller on opposite side to standard

Lever arm	Roller on opposite side		Reference	Weight
Length (a) Inches (mm)	Diameter (b) Inches (mm)	Width (c) Inches (mm)		kg (lb)
0.88 (22)	0.63 (16)	0.25 (6.3)	9007AA5	0.04 (0.09)
	0.63 (16)	0.63 (16)	9007AA6	0.04 (0.09)
1.38 (35)	0.75 (19)	0.25 (6.3)	9007BA15	0.04 (0.09)
	0.63 (16)	0.25 (6.3)	9007BA5	0.04 (0.09)
1.5 (38)	0.63 (16)	0.63 (16)	9007BA6	0.04 (0.09)
	0.75 (19)	0.25 (6.3)	9007MA15	0.04 (0.09)
2 (51)	0.63 (16)	0.25 (6.3)	9007MA5	0.04 (0.09)
	0.63 (16)	0.63 (16)	9007MA6	0.04 (0.09)
2.5 (63.5)	0.75 (19)	0.25 (6.3)	9007CA15	0.04 (0.09)
	0.63 (16)	0.25 (6.3)	9007CA5	0.04 (0.09)
3 (76)	0.63 (16)	0.63 (16)	9007CA6	0.04 (0.09)
	0.75 (19)	0.25 (6.3)	9007DA15	0.04 (0.09)
	0.63 (16)	0.25 (6.3)	9007DA5	0.04 (0.09)
	0.63 (16)	0.63 (16)	9007DA6	0.04 (0.09)
	0.75 (19)	0.25 (6.3)	9007EA15	0.04 (0.09)
	0.63 (16)	0.25 (6.3)	9007EA5	0.04 (0.09)
	0.63 (16)	0.63 (16)	9007EA6	0.04 (0.09)

Lever arms with roller countersunk roller pin

Arm	Roller (countersunk roller pin)		Reference	Weight
Length (a) Inches (mm)	Diameter (b) Inches (mm)	Width (c) Inches (mm)		kg (lb)
1.5 (38)	0.75 (19)	0.25 (6.3)	9007MA31	0.03 (0.07)
2 (51)	0.75 (19)	0.25 (6.3)	9007CA31	0.04 (0.08)
2.5 (63.5)	0.75 (19)	0.25 (6.3)	9007DA31	0.04 (0.09)

Lever arms with cable operated with eyebolt (I.D.) instead of roller

Arm	Cable	Reference	Weight
Length Inches (mm)	Length Inches (mm)		kg (lb)
1.5 (38)	0.38 (9.6)	9007MA22	0.05 (0.10)

Limit switches

9007C Heavy Duty Industrial

Plug-in body metal

Lever arms for rotary heads

DFE63135

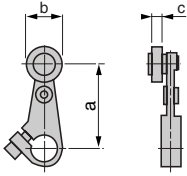

a : Length of lever Arm
b : Roller diameter
c : Roller width

Flat steel lever arms with standard roller

Arm	Roller	Reference	Weight
Length(a) Inches (mm)	Diameter (b) Width (c) Inches (mm) Inches (mm)		kg (lb)
Lever arms with steel roller			
0.88 (22)	0.63 (16) 0.25 (6.3)	9007AA1S	0.01 (0.03)
	0.63 (16) 0.63 (16)	9007AA2S	0.01 (0.03)
1.38 (35)	0.63 (16) 0.25 (6.3)	9007BA1S	0.01 (0.03)
	0.63 (16) 0.63 (16)	9007BA2S	0.01 (0.03)
2 (51)	0.63 (16) 0.25 (6.3)	9007CA1S	0.03 (0.07)
	0.63 (16) 0.63 (16)	9007CA2S	0.04 (0.08)
2.5 (63.5)	0.63 (16) 0.25 (6.3)	9007DA1S	0.04 (0.08)
	0.63 (16) 0.63 (16)	9007DA2S	0.04 (0.08)
3 (76)	0.63 (16) 0.25 (6.3)	9007EA1S	0.04 (0.08)
	0.63 (16) 0.63 (16)	9007EA2S	0.04 (0.08)
Lever arms with nylon roller			
1.38 (35)	1 (25.4) 0.25 (6.3)	9007BA4S	0.01 (0.03)
1.5 (38)	0.75 (19) 0.25 (6.3)	9007MA18S	0.01 (0.03)
2 (51)	1 (25.4) 0.25 (6.3)	9007CA4S	0.03 (0.07)
2.5 (63.5)	1 (25.4) 0.25 (6.3)	9007DA4S	0.04 (0.08)
3 (76)	1 (25.4) 0.25 (6.3)	9007EA4S	0.04 (0.08)
Lever arms without roller			
0.88 (22)	– –	9007AA0S	
1.38 (35)	– –	9007BA0S	0.01 (0.02)
2 (51)	– –	9007CA0S	0.03 (0.06)
2.5 (63.5)	– –	9007DA0S	0.03 (0.07)
3 (76)	– –	9007EA0S	0.03 (0.07)

DFE5318RZ



9007LA4

90° Forked cast zinc lever arms

Arm	Roller position	Roller	Reference	Weight
Length(a) Inches (mm)		Diameter (b) Width (c) Inches (mm) Inches (mm)		kg (lb)
Lever arms with steel roller				
1.5 (38)	Rollers on same side	0.75 (19) 0.25 (6.3)	9007LA4	0.05 (0.12)
		0.63 (16) 0.25 (6.3)	9007LA1	0.07 (0.15)
	R.H. Roller on opposite side	0.75 (19) 0.25 (6.3)	9007LA5	0.05 (0.12)
		0.63 (16) 0.25 (6.3)	9007LA2	0.07 (0.15)
	L.H. Roller on opposite side	0.75 (19) 0.25 (6.3)	9007LA6	0.05 (0.12)
		0.63 (16) 0.25 (6.3)	9007LA3	0.07 (0.15)
Lever arms with nylon rollers				
1.5 (38)	Rollers on same side	0.75 (19) 0.25 (6.3)	9007LA16	0.04 (0.09)
		1 (25.4)	9007LA10	0.06 (0.14)
	R.H. Roller on opposite side	0.75 (19) 0.25 (6.3)	9007LA17	0.04 (0.09)
		1 (25.4)	9007LA11	0.06 (0.14)
	L.H. Roller on opposite side	0.75 (19) 0.25 (6.3)	9007LA18	0.04 (0.09)
		1 (25.4)	9007LA12	0.06 (0.14)
Lever arms with ball bearing rollers				
1.5 (38)	Rollers on same side	0.69 (17.5) 0.25 (6.3)	9007LA7	0.11 (0.25)
	R.H. Roller on opposite side	0.69 (17.5) 0.25 (6.3)	9007LA8	0.11 (0.25)
	L.H. Roller on opposite side	0.69 (17.5) 0.25 (6.3)	9007LA9	0.11 (0.25)

Limit switches

9007C Heavy Duty Industrial

Plug-in body metal

Lever arms for rotary heads

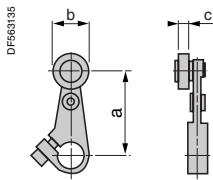

a : Length of lever Arm
b : Roller diameter
c : Roller width

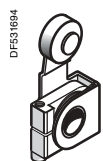

9007RA11

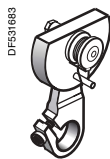

9007BA3

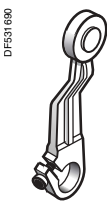

9007KA11

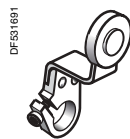

9007KB11

One-way lever arm

Arm	Steel roller		Reference	Weight
Length (a) Inches (mm)	Diameter (b) Inches (mm)	Width (c) Inches (mm)		kg (lb)
Lever arm with standard roller				
1.5 (38)	0.75 (19)	0.25 (6.3)	9007RA11	0.05 (0.12)
Lever arm with nylon roller				
1.5 (38)	0.75 (19)	0.25 (6.3)	9007RA18	0.05 (0.12)
Lever arm with ball bearing roller				
1.5 (38)	0.69 (17.5)	0.25 (6.3)	9007RA9	0.05 (0.12)
Lever arm with rod type				
5 (127)	–	–	9007FA2	0.05 (0.12)

One-way cast zinc roller lever arm

Arm	Roller		Reference	Weight
Length (a) Inches (mm)	Diameter (b) Inches (mm)	Width (c) Inches (mm)		kg (lb)
Cast arm with steel roller				
1.38 (35)	1.25 (32)	0.25 (6.3)	9007BA3	0.07 (0.15)
1.5 (38)	1.25 (32)	0.25 (6.3)	9007MA3	0.10 (0.23)
2 (51)	1.25 (32)	0.25 (6.3)	9007CA3	0.12 (0.27)
2.5 (63.5)	1.25 (32)	0.25 (6.3)	9007DA3	0.12 (0.27)
3 (76)	1.25 (32)	0.25 (6.3)	9007EA3	0.13 (0.29)
Flat steel arm with steel roller				
1.38 (35)	1.25 (32)	0.25 (6.3)	9007BA3S	0.07 (0.15)
2 (51)	1.25 (32)	0.25 (6.3)	9007CA3S	0.10 (0.23)
2.5 (63.5)	1.25 (32)	0.25 (6.3)	9007DA3S	0.12 (0.27)
3 (76)	1.25 (32)	0.25 (6.3)	9007EA3S	0.13 (0.29)

Offset type cast zinc lever arm

Offset lever arm		Roller		Reference	Weight
Length Inches (mm)	Offset	Diameter Inches (mm)	Width Inches (mm)		kg (lb)
Offset cast zinc arm with steel roller					
2 (51)	0.44 (11)	0.63 (16)	0.25 (6.3)	9007KA1	0.04 (0.08)
		0.63 (16)	0.63 (16)	9007KA2	0.04 (0.08)
		0.75 (19)	0.25 (6.3)	9007KA11	0.04 (0.09)
		0.75 (19)	0.63 (16)	9007KA12	0.05 (0.12)
1.5 (38)	0.88 (22)	0.75 (19)	0.25 (6.3)	9007KB11	0.04 (0.10)
		0.75 (19)	0.25 (6.3)	9007KB15	0.04 (0.10)
Offset cast zinc arm with ball bearing roller					
2 (51)	0.44 (11)	0.69 (17.5)	0.25 (6.3)	9007KA9	0.04 (0.10)
Offset cast zinc arm with nylon roller					
2 (51)	0.44 (11)	0.75 (19)	0.25 (6.3)	9007KA18	0.04 (0.10)
		0.75 (19)	1 (25.4)	9007KA21	0.04 (0.10)

Limit switches

9007C Heavy Duty Industrial

Plug-in body metal

Lever arms for rotary heads

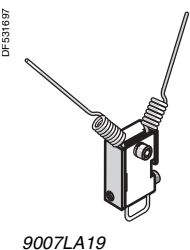
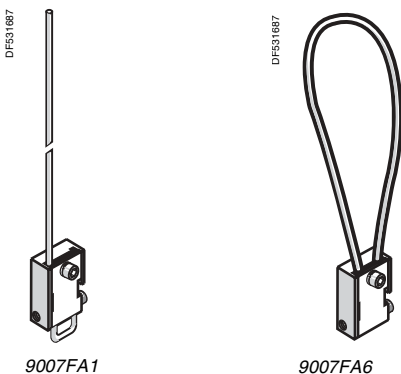
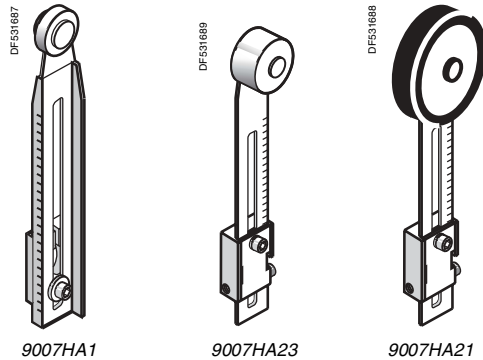
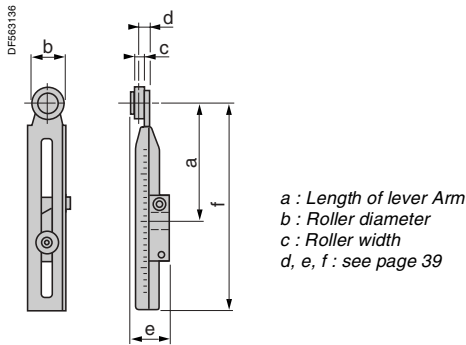

Adjustable length lever arm

Lever arm	Roller	Reference	Weight
Dimensions length(a) Inches (mm)	Diameter (b) Width (c) Inches (mm) Inches (mm)		kg (lb)

Adjustable length arm with steel roller

Non bendable, adjustable from 0.88 (22) to 4 (101)	0.63 (16)	0.25 (6.3)	9007HA1	0.05 (0.12)
	0.63 (16)	0.63 (16)	9007HA2	0.07 (0.14)
Bendable, adjustable from 0.88 (22) to 4 (101)	0.63 (16)	0.25 (6.3)	9007HA5	0.06 (0.14)
	0.63 (16)	0.63 (16)	9007HA6	0.04 (0.18)

Adjustable length arm with nylon roller

Non bendable, adjustable from 0.88 (22) to 4 (101)	0.63 (16)	0.25 (6.3)	9007HA4	0.05 (0.12)
	1 (25.4)	0.63 (16)	9007HA22	0.06 (0.13)
Bendable, adjustable from 0.88 (22) to 4 (101)	0.63 (16)	0.25 (6.3)	9007HA8	0.06 (0.14)
	1.0 (16)	0.63 (16)	9007HA23	0.07 (0.16)
	2 (51)	0.25 (6.3)	9007HA26	0.08 (0.17)

Adjustable length arm with ball bearing roller

Non bendable, adjustable from 0.88 (22) to 4 (101)	0.69 (17.5)	0.25 (6.3)	9007HA24	0.06 (0.13)
Bendable, adjustable from 0.88 (22) to 4 (101)	0.69 (17.5)	0.25 (6.3)	9007HA25	0.07 (0.16)

Adjustable length arm with ball DELRIN® roller

Bendable, adjustable from 0.88 (22) to 4 (101)	1.63 (41)	0.25 (6.3)	9007HA20	0.07 (0.16)
---	-----------	------------	-----------------	-------------

Adjustable length arm with rubber tire roller

Bendable, adjustable from 0.88 (22) to 4 (101)	2.13 (54)	0.5 (12.7)	9007HA21	0.10 (0.22)
---	-----------	------------	-----------------	-------------

Adjustable length arm without roller

Non bendable, adjustable from 0.88 (22) to 4 (101)	–	–	9007HA0	0.15 (0.33)
Bendable, adjustable from 0.88 (22) to 4 (101)	–	–	9007HA9	0.11 (0.25)

Rod type lever arm

Description	Length Inches (mm)	Reference	Weight kg (lb)
-------------	-----------------------	-----------	-------------------

Rod

Stainless steel rod	10 (254)	9007FA1	0.07 (0.15)
Spring rod, steel	12 (304)	9007FA3	0.07 (0.15)
Spring rod, DELRIN®	12 (304)	9007FA5	0.07 (0.15)
Looped DELRIN® rod arm	–	9007FA6	0.05 (0.11)

90° forked rod

Spring rods, steel	2.5 (63.5)	9007LA19	0.06 (0.13)
--------------------	------------	-----------------	-------------

Limit switches

9007C Heavy Duty Industrial

Plug-in body metal

Lever arms for rotary heads

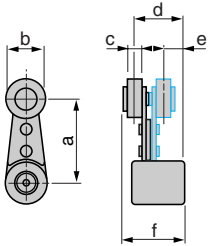

a : Length of lever Arm
 b : Roller diameter
 c : Roller width
 d, e : see page 39

360° angular adjustable lever arm

360° angular adjustable lever arm	Roller	Reference		Weight
Length (a) Inches (mm)	Roller (1) position	Diameter (b) Inches (mm)	Width (c) Inches (mm)	kg (lb)
Lever arms with steel roller				
0.88 (22)	Roller outside	0.63 (16)	0.25 (6.3)	9007AA1M 0.09 (0.20)
	Roller inside	0.63 (16)	0.25 (6.3)	9007AA5M 0.09 (0.20)
	Roller outside	0.75 (19)	0.25 (6.3)	9007AA11M 0.09 (0.22)
1.38 (35)	Roller outside	0.63 (16)	0.25 (6.3)	9007BA1M 0.09 (0.22)
	Roller inside	0.63 (16)	0.25 (6.3)	9007BA5M 0.10 (0.22)
	Roller outside	0.75 (19)	0.25 (6.3)	9007BA11M 0.10 (0.22)
1.5 (38)	Roller outside	0.63 (16)	0.25 (6.3)	9007MA1M 0.11 (0.24)
	Roller inside	0.63 (16)	0.25 (6.3)	9007MA5M 0.11 (0.24)
	Roller outside	0.75 (19)	0.25 (6.3)	9007MA11M 0.11 (0.24)
2 (51)	Roller outside	0.63 (16)	0.25 (6.3)	9007CA1M 0.11 (0.24)
	Roller inside	0.63 (16)	0.25 (6.3)	9007CA5M 0.11 (0.24)
	Roller outside	0.75 (19)	0.25 (6.3)	9007CA11M 0.11 (0.25)
2.5 (63.5)	Roller outside	0.63 (16)	0.25 (6.3)	9007DA1M 0.11 (0.25)
	Roller inside	0.63 (16)	0.25 (6.3)	9007DA5M 0.12 (0.27)
	Roller outside	0.75 (19)	0.25 (6.3)	9007DA11M 0.12 (0.27)
3 (76)	Roller outside	0.63 (16)	0.25 (6.3)	9007EA1M 0.12 (0.27)
	Roller inside	0.63 (16)	0.25 (6.3)	9007EA5M 0.12 (0.27)
	Roller outside	0.75 (19)	0.25 (6.3)	9007EA11M 0.13 (0.29)

Lever arms with nylon roller

0.88 (22)	Roller outside	0.63 (16)	0.25 (6.3)	9007AA8M 0.09 (0.20)
		0.75 (19)	0.25 (6.3)	9007AA18M 0.09 (0.20)
1.38 (35)	Roller outside	0.63 (16)	0.25 (6.3)	9007BA8M 0.11 (0.25)
		0.75 (19)	0.25 (6.3)	9007BA18M 0.11 (0.25)
1.5 (38)	Roller outside	0.63 (16)	0.25 (6.3)	9007MA8M 0.10 (0.23)
		0.75 (19)	0.25 (6.3)	9007MA18M 0.11 (0.25)
2 (51)	Roller outside	0.63 (16)	0.25 (6.3)	9007CA8M 0.12 (0.27)
		0.75 (19)	0.25 (6.3)	9007CA18M 0.12 (0.27)
2.5 (63.5)	Roller outside	0.63 (16)	0.25 (6.3)	9007DA8M 0.12 (0.27)
		0.75 (19)	0.25 (6.3)	9007DA18M 0.12 (0.27)
3 (76)	Roller outside	0.63 (16)	0.25 (6.3)	9007EA8M 0.12 (0.26)
		0.75 (19)	0.25 (6.3)	9007EA18M 0.12 (0.27)

Lever arms with ball bearing roller

0.88 (22)	Roller outside	0.69 (17.5)	0.25 (6.3)	9007AA9M 0.10 (0.23)
1.38 (35)	Roller outside	0.69 (17.5)	0.25 (6.3)	9007BA9M 0.11 (0.24)
1.5 (38)	Roller outside	0.69 (17.5)	0.25 (6.3)	9007MA9M 0.19 (0.26)
2 (51)	Roller outside	0.69 (17.5)	0.25 (6.3)	9007CA9M 0.19 (0.26)
2.5 (63.5)	Roller outside	0.69 (17.5)	0.25 (6.3)	9007DA9M 0.12 (0.27)
3 (76)	Roller outside	0.69 (17.5)	0.25 (6.3)	9007EA9M 0.13 (0.28)

(1) Roller can be changed in the field from roller outside to roller inside position or vice versa.

Limit switches

9007C Heavy Duty Industrial

Plug-in body metal

Bodies and heads

Body

Standard

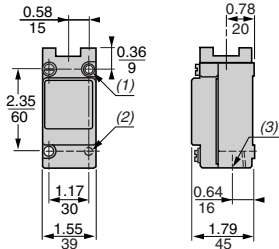

Dual dimensions : $\frac{\text{inches}}{\text{mm}}$

- (1) 2 x 0.20/5 x 0.22/6 HLS.
- (2) 2 x 10-24 Tapped HLS Back Mtg 0.29/7 DP.
- (3) 1/2 14 NPT.

Compact

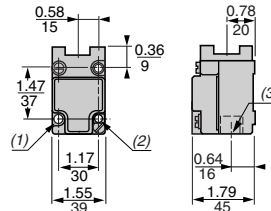

Dual dimensions : $\frac{\text{inches}}{\text{mm}}$

- (1) 2 x 0.20/5 HLS.
- (2) 2 x 10-24 Tapped HLS Back Mtg 0.20/5 DP.
- (3) 1/2 14 NPT.

Side plunger heads

9007F

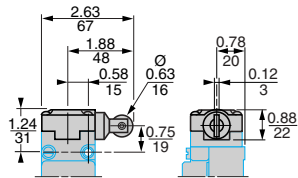

9007G

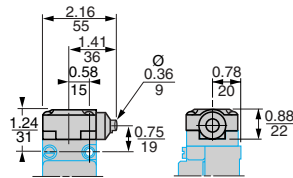

9007GD

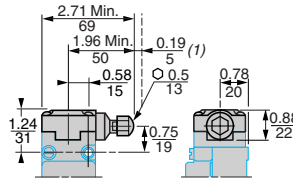

(1) Adjustable

9007H

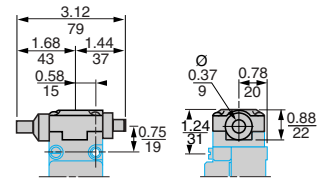

Top plunger heads

9007D

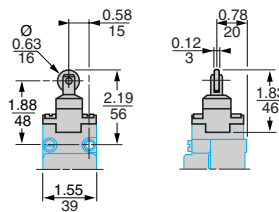

9007E

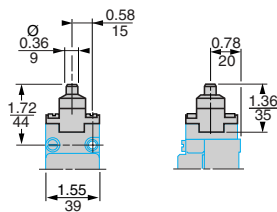

9007ED

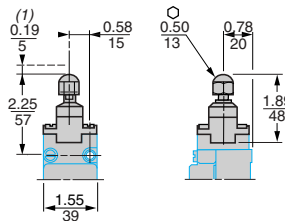

(1) Adjustable

Rotary heads

9007C

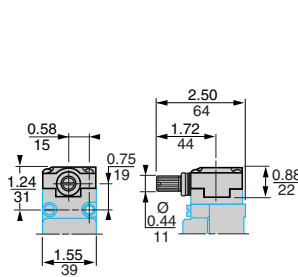

Multi-directional heads

9007JKC

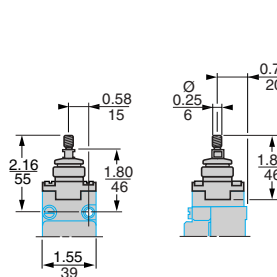

9007J

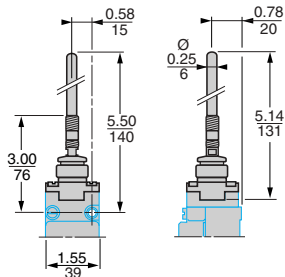

9007KC

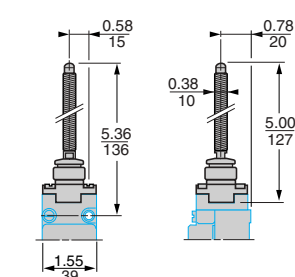

Multi-directional heads (continued)

9007K

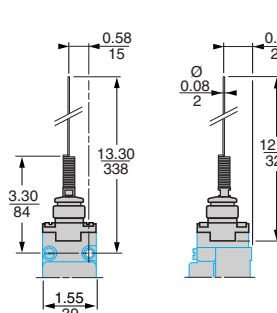

9007L

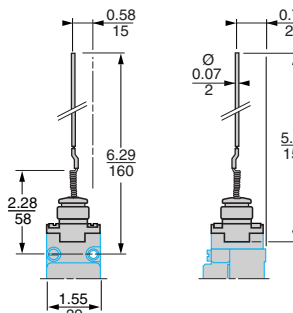

Limit switches

9007C Heavy Duty Industrial

Plug-in body metal

Lever arms for rotary heads

Lever arms

9007AA●●, BA●●, CA●●, DA●●, EA●●, FA●●, KA●●, LA●●, MA●●, RA●●

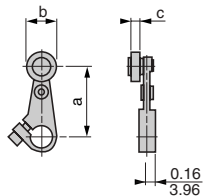

a : Length of lever Arm
b : Roller diameter
c : Roller width

a, b, c : pages 32 to 35

Adjustable length lever arms

9007HA● and 9007HA●●●

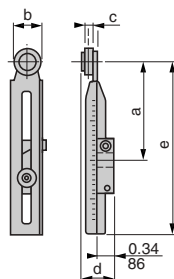

a : Length of lever Arm
b : Roller diameter
c : Roller width
d = 0.38/10
e = 4.38/111

a, b, c : page 36

360° angular adjustable lever arms

9007AA●●M, 9007BA●●M, 9007CA●●M, 9007DA●●M, 9007EA●●M, 9007MA●●M

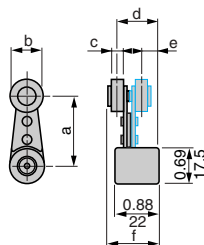

a : Length of lever Arm
b : Roller diameter
c : Roller width
d = 0.84/21
e = 0.38/10
f = 1.05/27

a, b, c : page 37

Rod type lever arms

9007FA1

9007FA6

9007LA19

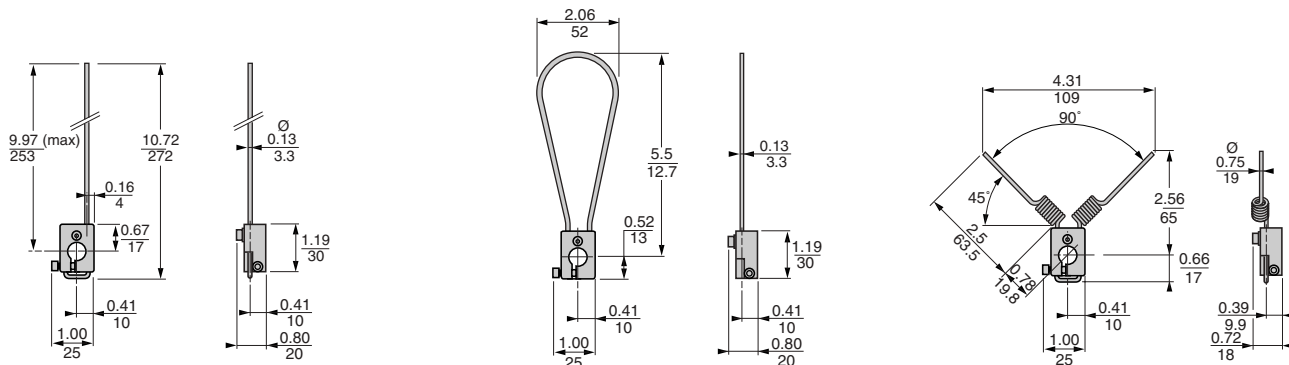

Limit switches

9007C Heavy Duty Industrial
 Hazardous location non plug-in body metal
 Conforming to NEMA 6P, 7, 9 and UL 508

■ Hazardous non plug-in body type (1)

□ With head for linear movement
 side plunger

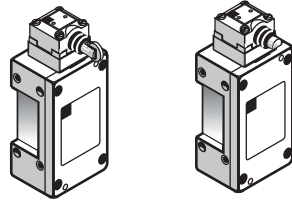

Page 42

top plunger

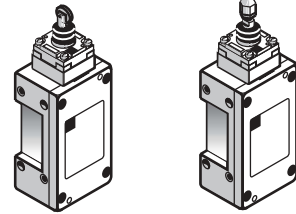

Page 43

□ With head for rotary movement
 (lever)

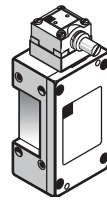

Page 44

With head for multi-directional
 movement

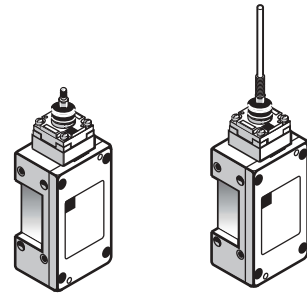

Page 45

(1) Factory modifications: see pages 18 to 22.

■ Application information - Hazardous locations

Classification of hazardous locations

Hazardous locations are those areas that **may** have flammable gases or combustible dusts present in quantities sufficient to produce an explosive or ignitable mixture. These gases, dusts, may always be present or may only be present in abnormal situations. The National Electrical Code (NEC) describes these areas in Articles 500 through 503 and divides them into three types of categories: Class, Group, Division.

■ **Classes**

The “Classes” (I, II, III) differentiate between the type of hazardous materials: I is for gases, II is for dusts, and III is for fibers.

■ **Groups**

The “Groups” (A, B, C, D, E, F, and G) further subdivide each class according to the relative explosive force of the materials. Group A atmosphere is acetylene which has a higher explosive force than Group B (which may contain hydrogen, for example); and Group B has a higher explosive force than Group D, etc.

■ **Divisions**

The “Divisions” (1 and 2) refer to the presence of these hazardous gases and dusts. Division 1 areas can have these gases or dusts present **at all times** under **normal operating conditions** in an ignitable concentration. Division 2 areas **only** have **ignitable concentrations** of dusts or gases present during **abnormal conditions**, such as machine failures or container breakage.

The table below gives a summary of the classifications described above.

Summary of classification chart

Class	Division	Group
I. Gas	1. Hazard May Exist May Exist In Atmosphere Under Normal Operating Conditions	A. Acetylene B. Manufactured Gases Containing Hydrogen C. Petrochemicals (e.g. ethylene) D. Petrochemicals (e.g. alcohol)
	2. Potential Hazard A. May be present in atmosphere only under abnormal circumstances.	A. Acetylene B. Manufactured Gases Containing Hydrogen C. Petrochemicals (e.g. ethylene) D. Petrochemicals (e.g. alcohol)
II. Dust	1. Hazard May Exist May Exist In Atmosphere Under Normal Operating Conditions	E. Conductive and Combustible Dust (Resistivity $\leq 10^5$ ohms/cm) F. Carbonaceous Dusts (Resistivity $> 10^2$ ohm/cm but < 108 ohm/cm) G. Non-Conductive Combustible Dust (Resistivity ≥ 105 ohms/cm)
	2. Potential Hazard A. May be present in atmosphere only under abnormal circumstances.	G. Non-Conductive Combustible Dust (Resistivity ≥ 105 ohms/cm)
III. Fibers	1. Production Areas	Easily Ignitable Fibers
	2. Handling and Storage Areas	Easily Ignitable Fibers

Limit switches

9007C Heavy Duty Industrial
 Hazardous location non plug-in body metal
 Conforming to NEMA 6P, 7, 9 and UL 508

Environment characteristics		
Conforming to standards	Products	NEMA 6P, 7 and 9 EN 60947-1, EN 60947-5-1, IEC 60947, UL 508, C22-2-14-95, CE conformity documentation
	Machine assemblies	IEC 60204-1
Product certifications		UL, CSA, CE
Protective treatment		Epoxy powder coat
Ambient air temperature (Lever/rotary head)	Operation	- 20...+ 185 °F (-28.9 °C...-85 °F), wider range available
	Storage	- 20...+ 185 °F (-28.9 °C...-85 °F), wider range available
Vibration resistance	Conforming to IEC 60068-2-6	25 gn (10...150 Hz, 11 ms) (C86F switch good for 18.5g only)
Shock resistance	Conforming to IEC 60068-2-27	60 gn (9 ms)
		40 gn (9 ms) for reed switch
Electric shock protection	Conforming to IEC 61140	Class 0
Degree of protection	Conforming to IEC 60529	IP 67
Cable entry or connector	Depending on model	1/2-14 NPT, M20 X 1.5, ISO cable gland, 5 pin mini connector, 4 pin micro connector
Materials	Bodies, heads, levers	Bodies in aluminum, heads in Zamak (zinc alloy), levers and rods in zinc, steel, stainless steel, delrin.
Contact block characteristics		
Rated operational characteristics hard contacts -AC Voltage	9007CR53 (single pole)	NEMA A600 (Ue = 600 V, Ie = 1.2 A); Ithe = 10 A
	9007CR61 (two pole)	NEMA A600 (Ue = 600 V, Ie = 1.2 A); Ithe = 10 A
	9007CR65 (two pole two stage)	NEMA A600 (Ue = 600 V, Ie = 1.2 A); Ithe = 10 A
	9007CR67 (two pole neutral)	NEMA A600 (Ue = 600 V, Ie = 1.2 A); Ithe = 10 A
Rated operational characteristics hard contacts -DC Voltage	9007CR53 (single pole)	NEMA Q600 (Ue = 600 V, Ie = 0.1 A); Ithe = 2.5 A
	9007CR61 (two pole)	NEMA R300 (Ue = 250 V, Ie = 0.11 A); Ithe = 1.0 A
	9007CR65 (two pole two stage)	NEMA R300 (Ue = 250 V, Ie = 0.11 A); Ithe = 1.0 A
	9007CR67 (two pole neutral)	NEMA R300 (Ue = 250 V, Ie = 0.11 A); Ithe = 1.0 A
Rated insulation voltage		600 V
Rated Impulse Withstand Voltage		2,500 VAC for 1 minute for CE, 2,200 VAC for 1 minute for UL, & 2,640 VAC for 1 sec. for CSA
Positive Opening	Special Y1561	Special Y1561 (one pole slow break only) ⊕
Short Circuit Protection		10 A. Bussman Class CC KTK-R-10 fuse Non time delay
Terminal wire sizes (Cabling/Screw Clamp)		1 or 2, 12-22AWG (2.05 mm ² - 0.644 mm ²) wires maximum
Maximum Actuation Speed		50fpm / 90fpm (15.2 m/min / 27.4 m/min) with 45 degree cam angle, levers only
Electrical Durability		1 million operating cycles

Types of contact elements

IEC 60947-5-1			NEMA			JIS		
Form	Symbol	Description	Form	Symbol	Description	Form	Symbol	Description
A		Single break	A		-	3		-
X								Double break
B		Single break	B		-	2		-
Y								Double break
C		-	C		-	1		Single break
Za		Same polarity	Z		"Same polarity" only			Double break
Zb		Electrically separate			-	-	-	

Limit switches

9007C Heavy Duty Industrial
Hazardous location non plug-in body metal
Conforming to NEMA 6P, 7, 9 and UL 508

Type of head Hazardous location non plug-in body type	Side Plunger (fixing by the body)			
Type of operator	Side roller plunger spring return vertical roller (1)	Side push rod plunger spring return	Side push rod plunger adjustable (2) spring return	Side push rod plunger maintained contact

References				
1 N.O. 1 N.C. snap action 	9007CR53F 	9007CR53G 	9007CR53GD 	9007CR53H
2 N.O. 2 N.C. snap action 	9007CR61F 	9007CR61G 	9007CR61GD 	9007CR61H
2 N.O. 2 N.C. Two stage snap action 	9007CR65F 	9007CR65G 	9007CR65GD 	
Weight kg (lb)	1.020 (2.25)	1.020 (2.25)	1.020 (2.25)	1.020 (2.25)
Contact operation				





Characteristics (nominal operating data)	
Switch actuation	On end
Type of actuation	
Pre-travel	2 mm (0.08")
Pre-travel two Stage	2 mm (0.08")
	First stage to second stage 0.5 mm (0.02")
Total travel	6.3 mm (0.25")
Differential	0.8 mm (0.03")
Reverse overtravel	-
Mechanical durability in millions of operating cycles	10
Minimum force or torque 1 pole & 2 pole	4 lb (17.8 N)
Terminal wire sizes (Cabling/Screw Clamp)	1 or 2, 12-22AWG (2.05 mm ² - 0.644 mm ²) wires maximum
Repeatability (linear travel of cam)	0.03 mm (0.001")
Cable entry	1/2-14 NPT standard, optional M20 x 1.5 mm for ISO cable gland

(1) Can be converted to horizontal roller type in the field. To order horizontal roller version add the letter **H** at the end of the equivalent vertical roller version type.
(2) To lock the nut in the desired position, crimp the slot near the bottom of the nut.

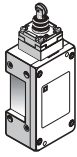
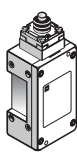
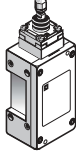
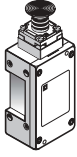
Limit switches

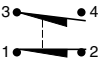
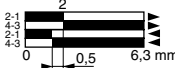
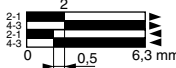
9007C Heavy Duty Industrial
Hazardous location non plug-in body metal
Conforming to NEMA 6P, 7, 9 and UL 508

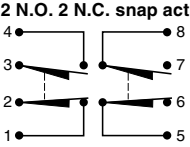
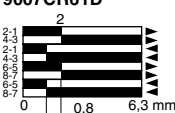
Type of head Hazardous location non plug-in body type	Top Plunger (fixing by the body)			
				
Type of operator	Top roller plunger spring return	Top push rod plunger spring return	Top push rod plunger adjustable (1) spring return	Palm operated (2)

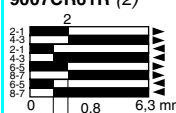
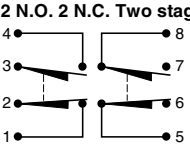
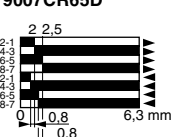
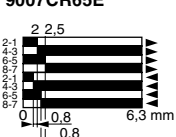
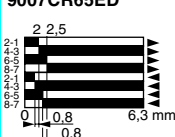
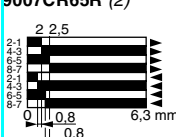
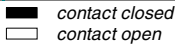
References				
1 N.O. 1 N.C. snap action 	9007CR53D 	9007CR53E 	9007CR53ED 	9007CR53R (2) 
2 N.O. 2 N.C. snap action 	9007CR61D 	9007CR61E 	9007CR61ED 	9007CR61R (2) 
2 N.O. 2 N.C. Two stage snap action 	9007CR65D 	9007CR65E 	9007CR65ED 	9007CR65R (2) 
Weight kg (lb)	1.020 (2.25)	1.020 (2.25)	1.020 (2.25)	1.020 (2.25)
Contact operation				



Characteristics (nominal operating data)	
Switch actuation	On end
Type of actuation	
Pre-travel	2 mm (0.08")
Pre-travel two Stage	First stage: 2 mm (0.08") First stage to second stage: 0.3 mm (0.01")
Total travel	6.3 mm (0.25")
Differential	0.5 mm (0.02")
Reverse overtravel	—
Mechanical durability in millions of operating cycles	10
Minimum force or torque 1 pole & 2 pole	3 lb (13.3 N) 7 lb (31.1 N)
Terminal wire sizes (Cabling/Screw Clamp)	1 or 2, 12-22AWG (2.05 mm ² - 0.644 mm ²) wires maximum
Repeatability (linear travel of cam)	0.03 mm (0.001")
Cable entry	1/2-14 NPT standard, optional M20 x 1.5 mm for ISO cable gland

(1) To lock the nut in the desired position, crimp the slot near the bottom of the nut.
(2) Does not include mushroom button. Must be ordered separately see page 31.

Limit switches

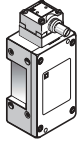
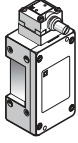
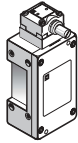
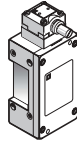
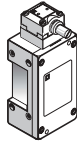
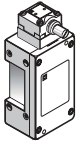
9007C Heavy Duty Industrial
Hazardous location non plug-in body metal
Conforming to NEMA 6P, 7, 9 and UL 508

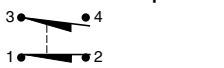
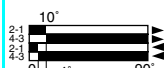
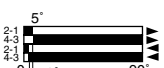
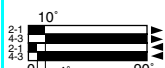
Type of head	Rotary (lever arm type) (1)					
Hazardous location non plug-in body type						
Type of operator	Standard pre-travel spring return	Low differential spring return	Neutral position Standard pre-travel spring return Low differential spring return		Light operating torque spring return	Maintained contact
Type of direction	CW & CCW (2)	CW & CCW (2)	CW & CCW	CW & CCW	CW & CCW (2)	CW (trip) CCW (reset)

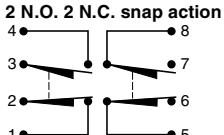
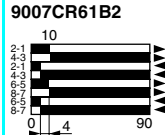
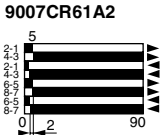
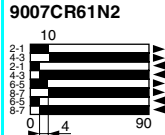
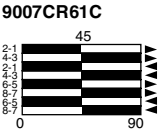
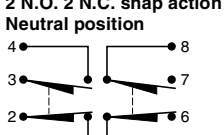
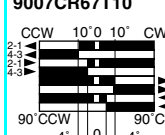
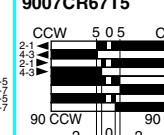
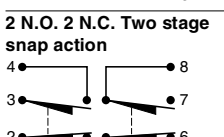
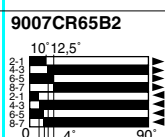
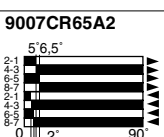
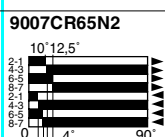
References						
1 N.O. 1 N.C. snap action 	9007CR53B2 	9007CR53A2 			9007CR53N2 	9007CR53C 
2 N.O. 2 N.C. snap action 	9007CR61B2 	9007CR61A2 			9007CR61N2 	9007CR61C 
2 N.O. 2 N.C. snap action Neutral position 			9007CR67T10 	9007CR67T5 		
2 N.O. 2 N.C. Two stage snap action 	9007CR65B2 	9007CR65A2 			9007CR65N2 	
Weight kg (lb)	1.020 (2.25)	1.020 (2.25)	1.020 (2.25)	1.020 (2.25)	1.020 (2.25)	1.020 (2.25)
Contact operation	■ contact closed			□ contact open		

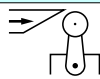
Characteristics (nominal operating data)						
Switch actuation	By 30° cam					
Type of actuation						
Pre-travel	10°	5°	10°	5°	10°	45°
Pre-travel two Stage						
- First stage	10°	5°	-	-	10°	-
- First stage to second stage	2.5°	1.5°	-	-	2.5°	-
Total travel	90°					90°
Differential	4°	2°	4°	2°	4°	-
Reverse overtravel	90°					-
Mechanical durability in millions of operating cycles	10					
Operating torque/force 1 pole & 2 pole	4 lb-in (0.45 N.m)				25 oz-in (0.18 N.m)	3 lb-in (0.34 N.m)
Terminal wire sizes (Cabling/Screw Clamp)	1 or 2, 12-22AWG (2.05 mm ² - 0.644 mm ²) wires maximum					
Repeatability (linear travel of cam)	0.05 mm (± 0.002")	0.03 mm (± 0.001")	0.05 mm (± 0.002")	0.05 mm (± 0.002")	0.05 mm (± 0.002")	0.05 mm (± 0.002")
Cable entry	1/2-14 NPT standard, optional M20 x 1.5 mm for ISO cable gland					

(1) Lever arm type must be ordered separately from page 32 to 37.

(2) These devices are factory set to operate the contacts in both the CW and CCW directions. Mode of operation is field convertible to CW only or CCW only.

To order factory converted devices - for CCW only operation, change the "2" at the end of the type number to "1" (Example : C54B2 becomes C54B1) - for CW only operation, delete the "2" at the end of the type number (Example C54B2 becomes C54B).

Mode change of lever arm is easily convertible to clockwise, or both.

Simply point the arrow to the letters representing the desired direction - CW, CCW, or CW/CCW.

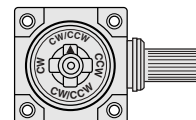

Limit switches

9007C Heavy Duty Industrial
Hazardous location non plug-in body metal
Conforming to NEMA 6P, 7, 9 and UL 508

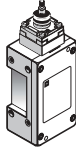
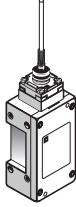
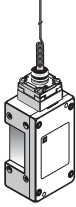
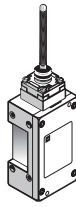
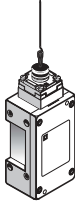
Type of head Hazardous location non plug-in body type	Flexibe operator (wobble stick)				
					

Type of operator	Universal (1)	Wobble stick DELRIN extension (1)	Wobble stick wire extension (1)	Wobble stick coil spring extension (1)	Cat whisker
-------------------------	---------------	-----------------------------------	---------------------------------	--	-------------

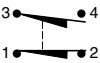
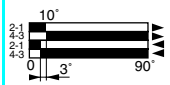
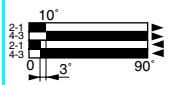
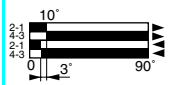
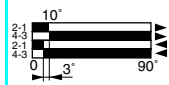
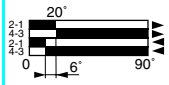
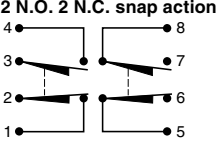
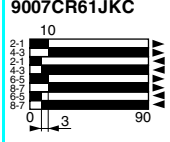
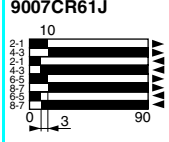
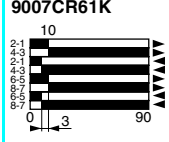
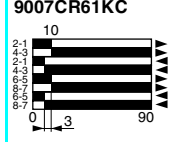
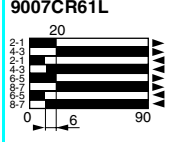
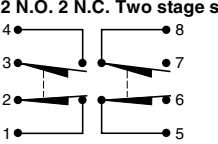
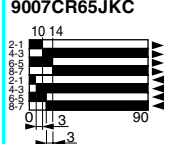
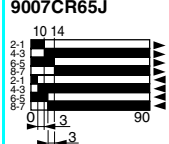
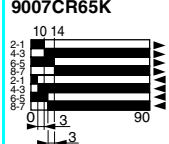
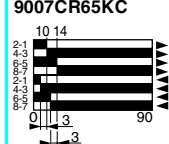
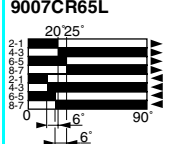
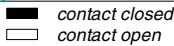
References					
1 N.O. 1 N.C. snap action 	9007CR53JKC 	9007CR53J 	9007CR53K 	9007CR53KC 	9007CR53L 
2 N.O. 2 N.C. snap action 	9007CR61JKC 	9007CR61J 	9007CR61K 	9007CR61KC 	9007CR61L 
2 N.O. 2 N.C. Two stage snap action 	9007CR65JKC 	9007CR65J 	9007CR65K 	9007CR65KC 	9007CR65L 
Weight kg (lb)	1.020 (2.25)	1.020 (2.25)	1.020 (2.25)	1.020 (2.25)	1.020 (2.25)
Contact operation					

Characteristics (nominal operating data)

Switch actuation	By any moving object from any direction	
Type of actuation		
Pre-travel	10° (any direction)	20°
Pre-travel two Stage		
- First stage	10° (any direction)	20°
- First stage to second stage	4°	5°
Total travel	90°	
Differential	3	6°
Reverse overtravel	-	
Mechanical durability in millions of operating cycles	10	
Operating torque/force 1 pole & 2 pole	3 lb-in (0.34 N.m)	7 oz-in (0.05 N.m)
Terminal wire sizes (Cabling/Screw Clamp)	1 or 2, 12-22AWG (2.05 mm ² - 0.644 mm ²) wires maximum	
Repeatability (linear travel of cam)	-	
Cable entry	1/2-14 NPT standard, optional M20 x 1.5 mm for ISO cable gland	

(1) Wobble stick extensions are available separately for the universal head or as replacements for complete devices (see page 31)

Limit switches

9007C Heavy Duty Industrial

Hazardous location non plug-in body metal

Conforming to NEMA 6P, 7, 9 and UL 508

Side Plunger

9007C●●F

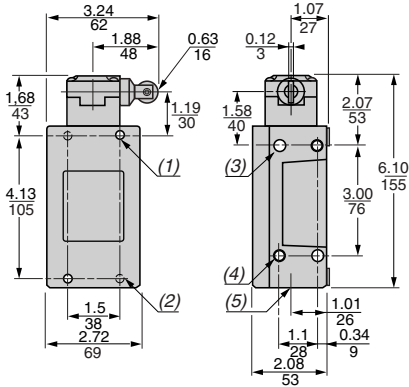

9007C●●G

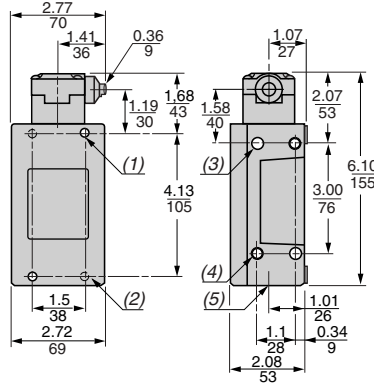

9007C●●GD

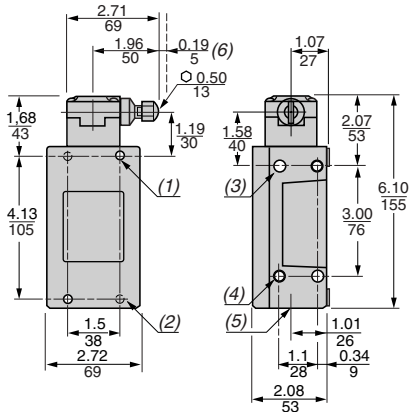

9007C●●H

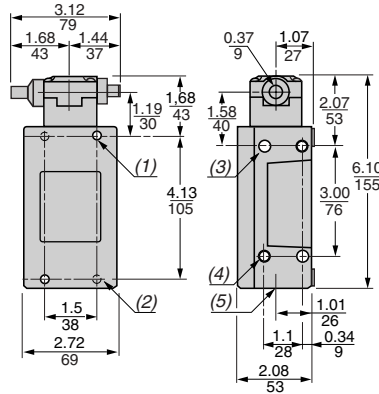

Dual dimensions : $\frac{\text{inches}}{\text{mm}}$

- (1) 2 x 0.27/7, front Mtg holes.
- (2) 2 x 0.63/16 1/4-20 DP UNC-2B back mounting holes.
- (3) 2 x 0.26/7 dia. holes.
- (4) 2 1/4-20 UNC-2B, both sides 0.32/8 DP.
- (5) 1/2 or 3/4 NPT.
- (6) Adjustable.

Top Plunger

9007C●●D

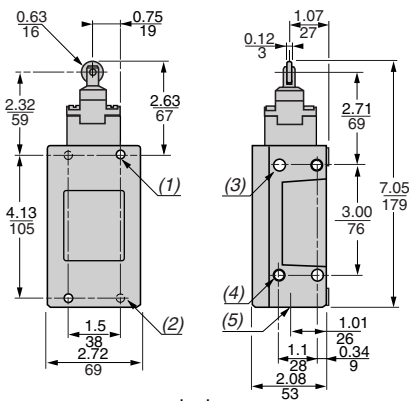

9007C●●E

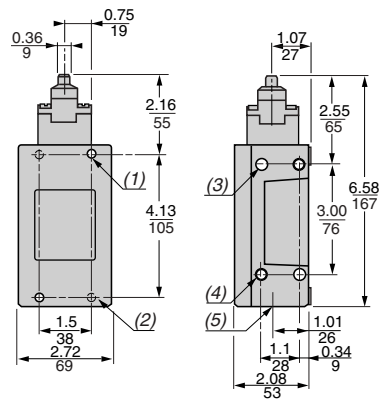

9007C●●ED

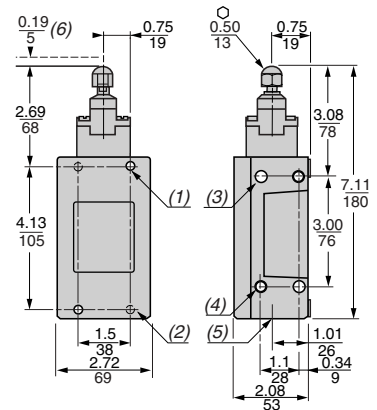

Dual dimensions : $\frac{\text{inches}}{\text{mm}}$

- (1) 2 x 0.27/7, front Mtg holes.
- (2) 2 x 0.63/16 1/4-20 DP UNC-2B back mounting holes.
- (3) 2 x 0.26/7 dia. holes, back Mtg. holes.
- (4) 2 1/4-20 UNC-2B, both sides 0.32/8 DP.
- (5) 1/2 or 3/4 NPT.
- (6) Adjustable.

Limit switches

9007C Heavy Duty Industrial
 Hazardous location non plug-in body metal
 Conforming to NEMA 6P, 7, 9 and UL 508

Rotary

9007C●●●●

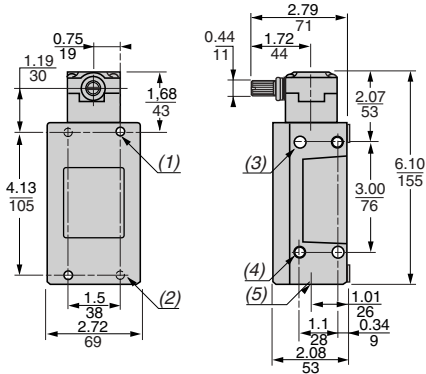

Dual dimensions : $\frac{\text{inches}}{\text{mm}}$

- (1) 2 x 0.27/7, front Mtg holes.
- (2) 2 x 0.63/16 1/4-20 DP UNC-2B back mounting holes.
- (3) 2 x 0.26/7 dia. holes, back Mtg. holes.
- (4) 2 1/4-20 UNC-2B, both sides 0.32/8 DP.
- (5) 1/2 or 1/4 NPT.

Wobble stick

9007C●●JKC

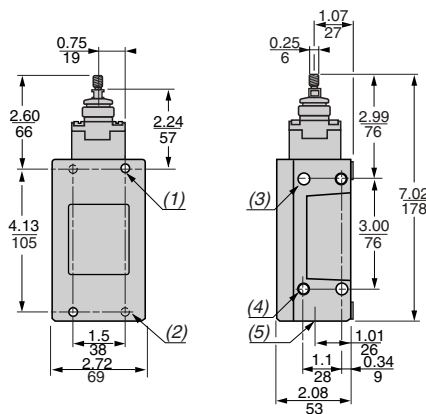

9007C●●J

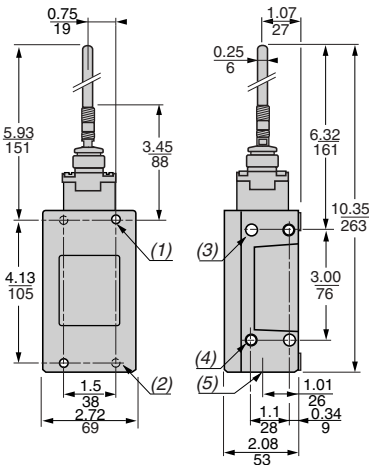

9007C●●K

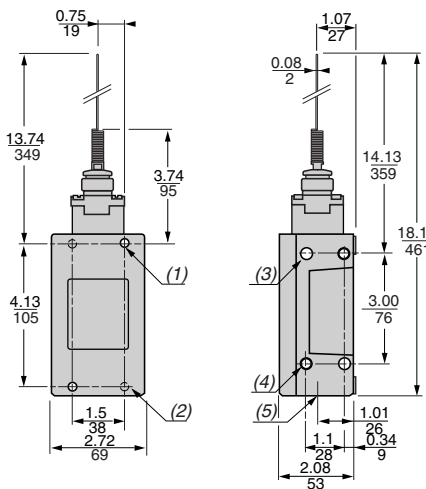

9007C●●KC

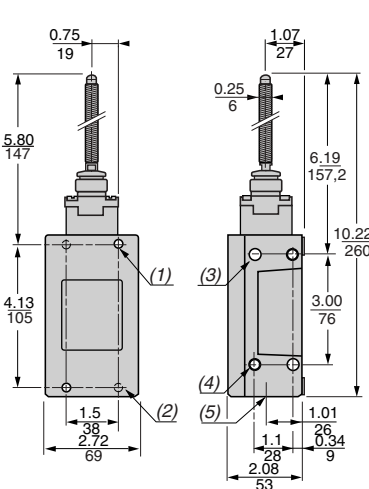

9007C●●L

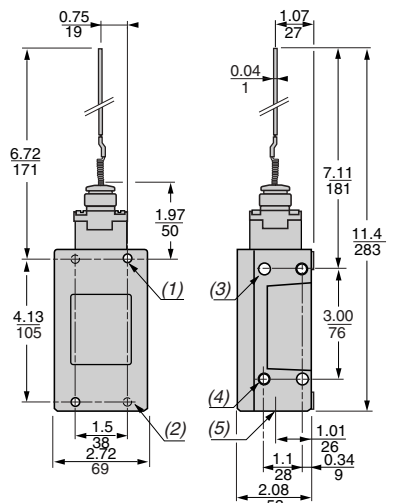

Dual dimensions : $\frac{\text{inches}}{\text{mm}}$

- (1) 2 x 0.27/7, front Mtg holes.
- (2) 2 x 0.63/16 1/4-20 DP UNC-2B back mounting holes.
- (3) 2 x 0.26/7 dia. holes, back Mtg. holes.
- (4) 2 1/4-20 UNC-2B, both sides 0.32/8 DP.
- (5) 1/2 or 1/4 NPT.

Limit switches

9007C limit switches

Basic technical concepts

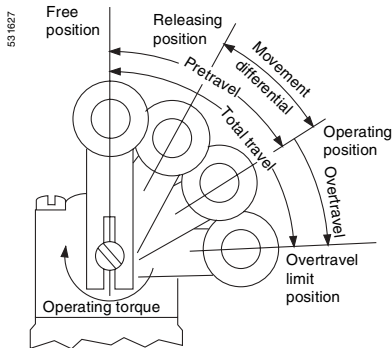

Figure 1: Rotary lever type

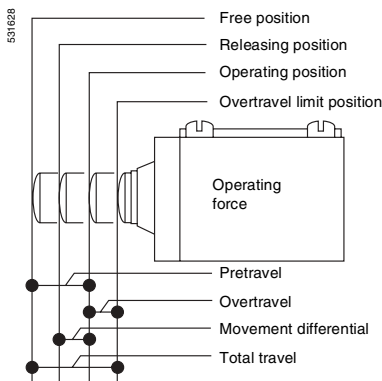

Figure 2: Linear (or Plunger) type

Glossary

CCW - Counterclockwise only (for lever types).

CW - Clockwise only (for lever types).

Differential - The movement differential or differential is the distance or angle from the operating position to the releasing position.

Free or normal position - Free or normal position is the initial position of the actuator when there is no external force (other than gravity) applied on the actuator.

Neutral position - Lever operated switch with a minimum of two contacts. One contact changes state only when lever moves CW. The second contact changes state only when the lever moves CCW. (The center position is the free position.)

Operating position - Operating position is the position of the actuator at which the contacts change state.

Overtravel - Overtravel is the distance or angle through which the actuator moves when traveling from the operating position to the overtravel limit position.

Pre-travel - Pre-travel is the distance or angle through which the actuator moves from the free position to the position at which the contacts change state, the operating position.

Release position - Release position is that position of the actuator at which the contacts change state from the operated contact position to the normal contact position.

Release torque - Release torque is the value to which the torque on the actuator must be reduced to allow the contacts to change state from the operated position to the normal contact position.

Actuator-lever - An actuator is the mechanism of the switch or enclosure which, when moved as intended, will operate the contacts.

Maintained contact limit switch - A maintained contact limit switch is a switch which remains in a given condition until actuated to another condition, which is also maintained until further actuation.

Momentary contact limit switch - A momentary contact limit switch is a switch which returns from the operated condition to its free or normal circuit condition when the actuating force is removed.

N.C. - Normally closed contact, when the switch mechanism is at its free or normal position.

N.O. - Normally open contact, when the switch mechanism is at its free or normal position.

Operating torque - Operating torque (force) is the minimum torque (force) value which must be applied to the actuator to cause the contacts to change state.

Overtravel limit position - Overtravel limit position is that position of the actuator beyond which further overtravel would cause damage to the switch or actuator.

Repeatability - Repeatability is the ability to consistently maintain the original operating characteristics. Measured by the difference between the operating position of a new switch and of the same after 1 million operations.

Total travel - Total travel is the sum of the pre-travel and overtravel.

Travel - Movement of the actuator from its free or normal position when force is applied. (See pre-travel and over travel.)

Limit switches

9007C limit switches

Technical Information

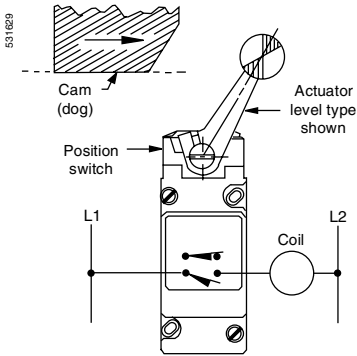

Figure 3 - Limit switch

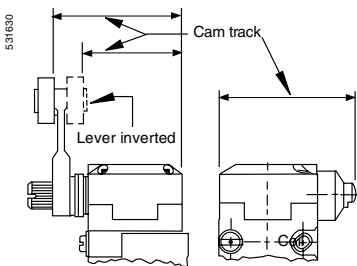

Figure 4 - Cam track dimension

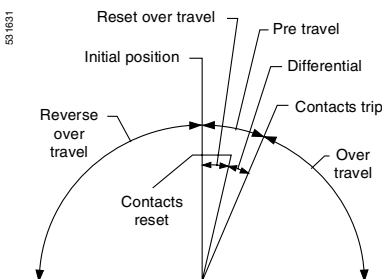

Figure 5 - Contact travel

Glossary (continued)

Definition of limit switch terms

There are many terms common to position switches that are not used with other control devices. Before proceeding further, definitions of the commonly used terms should be understood as these terms will be used throughout this document.

Limit switch - A device that converts a mechanical motion into an electrical control signal.

Actuator - The mechanism of a limit switch that operates the contacts, i.e., lever arm, plunger, wobble stick.

Cam - A machine part or component that applies force to the switch actuator causing it to move as intended. Also known as "dog".

Cam track dimension - The distance from the switch mounting surface to some point on the roller or actuator.

Differential - The distance that the limit switch actuator moves, from the trip point to the reset point of the contacts.

Direct-acting/positive opening contacts - Normally closed contacts that are moved directly by the operating shaft. They are slow make-slow break contacts and have a shorter life than snap action contacts due to longer arcing times. In general, these should only be used where movement of actuator must break welded contacts, as in a crane safety limit switch. (Snap action positive opening contacts are available in the Telemecanique XCKJ limit switch.)

Maintained contacts - Contacts that remain in the tripped position until the return travel of the cam moves the switch actuator back and resets the contacts.

Neutral (free or normal) position limit switch - A lever arm type switch with two sets of contacts. One set operates when the shaft is rotated clockwise; the other operates when the shaft is rotated counterclockwise.

Operating force - The force required to move limit switch actuator to cause the contacts to change state.

Overtravel - The distance that the position switch actuator may move beyond the trip point, (see figure 5) without damage to the switch.

Pole - The number of moveable contacts in a switching mechanism. A single pole device may be 1 N.O., 1 N.C. or 1 N.O. and 1 N.C. with a single set of moveable contacts is used to bridge those stationary contacts. A double or two pole switch has two moveable contacts.

Positive break contacts - Normally closed contacts with a special mechanism to insure opening. Can be snap acting positive break or direct acting slow make, slow break type. The slow break direct acting type is not recommended for high cycle applications due to shorter life.

Pre-travel - The distance that the limit switch actuator must move to trip the contacts.

Reed contacts - A mechanism consists of a set of contacts hermetically sealed in a glass envelope and actuated by a magnet attached to the operator. This sealed construction keeps contaminants out of the contact area, making the reed switch ideal for low voltage, low current circuits such as programmable controllers.

Reset point - The position of the actuator at which the contacts return to the normal position.

Snap action contacts - Contacts that move rapidly to open or closed position and are relatively independent of cam speed. Because of shorter arcing times, snap acting contacts have longer contact life than slow make and break contacts and should be used where fast moving cams are encountered or where good repeat accuracy is required.

Spring return - Contacts that return to their original position when the actuating force is removed.

Limit switches

9007C limit switches

Technical Information

Definition

Slow break contacts - The speed of transfer of the moveable contacts is dependent on the speed of the operator. The amount of travel of the moveable contacts is also dependent on the amount of travel by the operator. Slow make and break contacts have the same trip and reset points, and do not have the differential travel common to snap switches.

Snap action contacts - The speed of transfer of the moveable contacts is not dependent on the speed of the operator. The amount of travel of the moveable contacts is also not dependent on the amount of travel by the operator. The movement of the moveable contacts are determined by a preset travel, after this point is reached, the contacts will trip. Snap action contacts have different trip and reset points, the difference is identified as "differential".

Flexible operators - Flexible resilient or elastic operators, i.e., wobble sticks, do not ensure direct opening/positive opening action.

Isolated contacts - Single-pole double-throw (SPDT) contacts with four terminals which have two isolated contact bars mechanically linked. No polarity restrictions apply. Different (isolated) power supplies can also be applied.

Same polarity - Single-pole double throw (SPDT) contacts with four terminals that require the supply to be applied with the same polarity (i.e., L1 or +) on the same side of the contact bar. Two different supplies are not allowed in this configuration. (The loads should always be on the same side of the contact bar.)

Direct opening contact (also known as positive opening contacts) - A normally closed contact element coupled with the switch actuator via a non-resilient (non elastic) member so that full contact opening is obtained when the actuator is moved through the direct opening travel by applying a direct opening force. The contact element will shear open in the event of sticking contacts or broken springs. Proper fusing of the control circuit is required. Direct opening contacts meet IEC 60947-5-1 requirements.

Direct opening travel (also known as positive opening travel) - Minimum travel from the actuator free position to the position where the direct opening operation is completed. Usually longer than the normal pre-travel.

Reed contacts - Contact mechanism consists of a set of contacts hermetically sealed in a glass envelope and actuated by a magnet attached to the operator. This sealed construction keeps contaminants out of the contact area, making the reed switch the ideal switch for low voltage, low current circuits such as programmable controllers.

Note: Because reed switches are operated by a magnet, they should not be installed in areas where strong magnetic fields may be present. The devices should always be checked for proper operation after installation.

Polarity

Opposite polarities should not be connected to the contacts of one limit switch unless the limit switch is specifically designed for such service (isolated contacts - no polarity). See page 51.

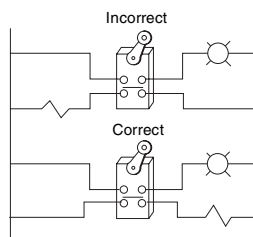

Power sources

Power from different sources should not be connected to the contacts of one limit switch unless the switch is specifically designed for such service (isolated contacts - no polarity).

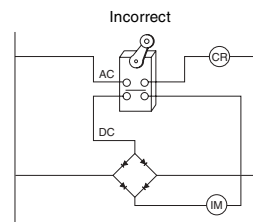

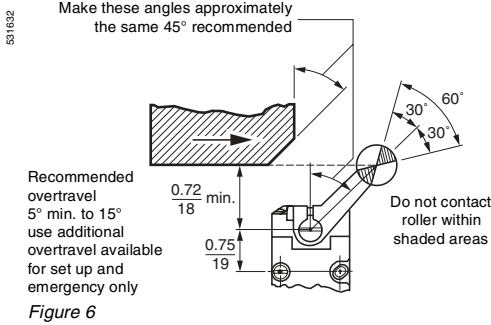

Figure 6

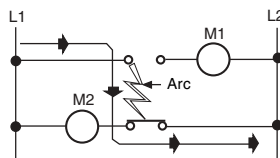
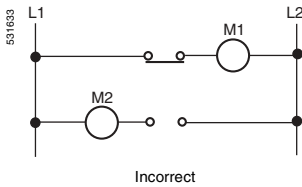

Figure 7 - Contacts connected to opposite polarities. Line to line short (bold line) can occur through arc drawn when contacts operate

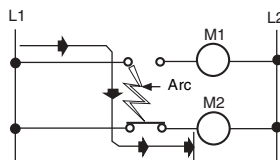
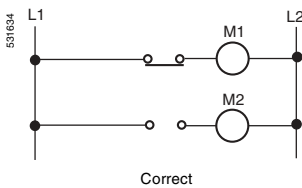

Figure 8 - Contacts connected to same polarity. Line to line short cannot occur when contacts operate

Overriding Cams

The cam trailing edge on overriding cams must also be considered for maximum switch life (see figure 6). Lever arm snap back causes shock loads which reduce switch life. Also, with reversing cams the trailing edge becomes a leading edge on the return stroke. The overtravel of the limit switch should not be exceeded, but 5° minimum to 15° travel past the trip point is recommended. Additional travel should only be used for set up and emergencies. Cam design procedures for limit switches with other than lever arm actuators vary from switch type to switch type and are discussed along with other limit switch application design suggestions in additional literature "Proper Application of Limit Switches" (SM444).

Contacts

- Make sure electrical load is within limit switch contact ratings.
- The single pole, double throw contacts of a snap switch used in a limit switch should not be used on opposite polarities. When load M1 is connected between the contact and line L2 and load M2 is connected between the other contact and line L1 (figure 7), a line-to-line short (bold line) can occur through the arc which may be drawn as the contacts operate. When contacts are connected to the same polarity (figure 8), this line-to-line short cannot occur. The same result can occur if different power sources are connected to the single pole, double throw contacts of a snap switch.
- When applying limit switches having reed contacts, it is suggested that some form of transient protection be used. This will protect the small contacts from damaging surges and will increase contact life.

Coolant

- When possible, avoid mounting limit switches where they will be constantly exposed to coolant, chips, etc. Although designed for such applications, switches obviously will last longer when not exposed to these contaminants.
- Make sure cover screws are tightened to assure a good oiltight seal.
- When possible, avoid use of fire resistant coolants of the phosphate ester type. Equipment exposed to these coolants requires special seals and gaskets. Viton, a material resistant to these types of coolants, is the standard shaft seal material on Type C lever arm types. If required, all gaskets, as well as boots on plunger types, can be furnished in Viton.

Installation of conduit

Limit switch leakage is very often traced to the conduit system. Coolant or condensation in the conduit line can enter the switch through the conduit entry. Oil tightness is dependent upon the condition of the conduit connection and seal. Recommendations for installing conduit to position switches are as follows:

- To insure an oiltight seal, use thread sealant and a conduit seal or a sealing bushing around the conduit fitting. If this is not done, the fitting probably will leak.
- Limit switches should be installed with the conduit end down whenever possible.
- If condensation or moisture is present inside the conduit, a Square D conduit seal can be inserted in the conduit entry. The conduit fitting can then be connected in the normal manner. Thread sealant and a sealing bushing must still be used.
- Often a junction box fills with coolant and/or condensation which backs up into the position limit through the conduit. A simple solution is to drill a hole in the bottom of the junction box to allow the liquid to drain out.
- If conduit leakage is severe, pre-wired and potted position limit (Forms Y184● and Y185●) should be used. The switches are pre-wired with either individual wires or multiconductor STOWA cord and the receptacle is sealed with a potting material.
- The Square D limit switch is available with a pre-wired male plug receptacle. The connector provides an effective oiltight seal when used with the appropriate female connector cord.

Terminal Identification

European (IEC) contact terminals marking

Single pole	Double pole	
	1 st pole	2 nd pole
11-12	11-12	21-22
13-14	13-14	23-24
11-12	11-12	21-22
13-14	13-14	23-24

Each terminal is marked with 2 digits: First digit indicates the pole (circuit). The second digit indicates the type of contact:

_1 - _2 is N.C., _3 - _4 is N.O.

i.e.: 11-12, 21-22 are N.C. 13-14, 23-24 are N.O.

Example of European Terminal Markings:

For switch elements without isolated contacts:

11-12 Is the N.C. contact of pole No. 1, 13-14 Is the N.O. contact of pole No. 2

For switch elements with isolated contacts:

13-14 Is the N.O. contact of pole No. 1, 21-22 Is the N.C. contact of pole No. 2

Example of US Terminal Markings

Single pole	Double pole	
	1 st pole	2 nd pole
1-2	1-2	5-6
3-4	3-4	7-8
1-2	1-2	5-6
3-4	3-4	7-8

Each contact terminal is marked with one digit, i.e., 1-2, 3-4, 5-6,7-8.

Example of US Terminal Markings:

For most snap switch elements (isolated contacts not usually on US manufactured switches):

1-2 is the N.C. contact of pole No. 1,

3-4 is the N.O. contact of pole No. 1

5-6 is the N.C. contact of pole No. 2,

7-8 is the N.O. contact of pole No. 2



Make-before-break (overlapping) SPDT: the normally open contact closes before the normally closed contact opens.

Break-before-make (offset) SPDT: the normally closed contact opens before the normally open contact closes.

Simultaneous make and break - SPDT: the normally closed contact opens at the same time as the normally open contact closes.

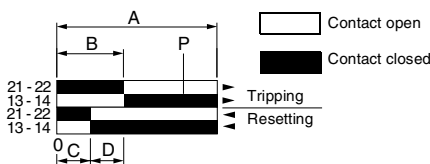

A = Maximum travel of the operator in mm or degrees.

B = Tripping travel of the contact.

C = Resetting travel of contact.

D = B - C = Differential travel.

P = Point from which positive opening is assured.

Note: The arrows indicate direction of actuation clockwise (CW) and return for simplicity reasons. For counterclockwise (CCW) only direction of actuation is reversed.

Wiring diagrams

Form A SPST-NO	Form B SPST-NC	Form C SPDT	Form AA DPST-NO	Form BB DPST-NC
Form CC DPDT	Form X SPST-NO-DB	Form Y SPST-NC-DB	Form Zb SPDT isolated contacts	Form Z DPDT-DB
Form XX DPST-NO-DB	Form YY DPST-NC-DB	Form ZZ DPDT-DB		

Limit switches

9007C limit switches

Cam design

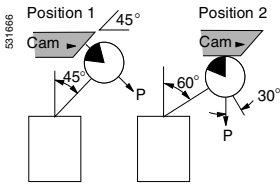

Fig "1a" cam design for speeds up to 50 fpm

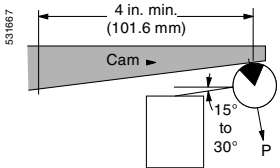

Fig "1b" cam design for speeds between 50 fpm and 200 fpm (15.2 mpm and 60.9 mpm).

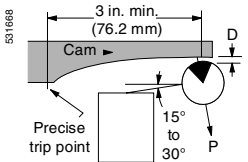

Fig "1c" cam design for speeds between 200 fpm and 400 fpm (60.9 mpm and 121.9 mpm).

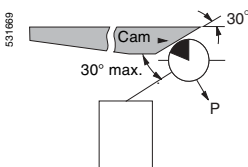

Figure 2

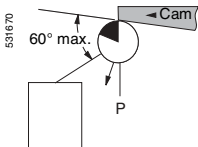

Figure 3

Application information

Excessive impact from improperly designed actuating systems is without question the leading cause of premature failure of the electromechanical limit switch. At slow speed, impact is rarely troublesome, but as speed increases, impact applied to the switch becomes a critical problem. In today's higher speed machines, therefore, it is important to give proper consideration to correctly designed actuating systems.

These recommendations are designed to assist you in obtaining greater life from your limit switches. The black sector in the roller indicates the recommended design limits of the angle of pressure shown in the illustrations as "P". Three main design and installation considerations are:

- The pressure applied by the actuating mechanism to switch operating lever should approximate direction of lever rotation with a variation not to exceed 30°.
- Since the angle of pressure changes drastically with rotation of the lever, the cam must be designed for proper pressure angles at all positions of the lever travel.
- The switch operating levers should be positioned as nearly parallel with the leading edges of the cams as possible.

Considering these three factors, cam in Fig "1a" is satisfactory for speeds up to 50 fpm (15.2 mpm), cam in Fig "1b" is suitable for speeds up to 200 fpm (60.9 mpm) (nonuniform acceleration of switch lever), cam in Fig "1c" is satisfactory for speeds up to 400 fpm (121.9 mpm) (uniform or other controlled acceleration).

Designing proper pressure angles For overriding cams for electromechanical limit switches

Don't underestimate the importance of adjusting cams and operating levers in electromechanical limit switches to provide for the proper pressure angles in every travel position. Without the means to control the angle of pressure or the limit of override, the operating lever may spring back with damaging results. **Usual results of lever flyback are double pulsing of the contacts, as well as additional stresses placed on the mechanical system of the limit switch.** The excessive impacts absorbed from inadequately designed actuating devices will eventually lead to abnormal wear and premature failure of the electromechanical limit switch.

With a closer look at the actuating angles of the cam surface, it is possible for every designer or engineer to obtain the maximum operating life from every electromechanical limit switch installed. The following recommendations are intended to provide a workable knowledge of proper lever and cam angles - and how they are applied to secure optimum conditions:

- Actuating cam on machinery or slide should provide a trailing edge so that upon overriding the operating lever will not snap back.
- During the approach phase, **the pressure angle of the cam should not vary from the lever angle more than 30°.**
- On the override phase, **the angle of the trailing edge of the cam to the lever should be no more than 60°.**

If these guidelines are followed, the switch operating levers will always be approximately parallel with the leading edges of the actuating surfaces or cams.

Figure 2 shows leading edge of cam about to depress and actuate the electromechanical limit switch. The black sector of the roller indicates the recommended design limits of the angle of pressure shown in drawings as "P".

Figure 3 shows operating lever roller following the trailing edge of the cam on the override cycle. Unless a one-way lever is used, the cam will operate the switch on the return cycle.

Limit switches

9007C limit switches

Linear/angular lever travel

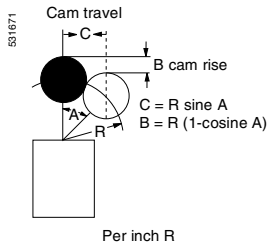

Application information (continued)

The table below can be of assistance to both the designer of machine tools and conveyors as well as the plant engineer or maintenance personnel responsible for keeping this equipment in a satisfactory operating condition.

The design engineer will find the table useful in making trouble-free cam layouts. For example, if the recommended operating travel for a switch is between 15° and 30°, use the table to figure cam rise and travel. This aids in determining what type of cam to design, its dimensions, etc.

The plant engineer on the other hand can use the table to ascertain where to position levers on replacement switches or revamped circuitry to operate existing cams. The engineer can also use the table to position the lever in proper relationship to the cam, and to find out whether switches and cams are installed properly to obtain maximum switch life.

All dimensions in the table are for 1" (25.4mm) levers. If you use longer levers, multiply the figures by the increased lever length. For example, for a 2" (51mm) lever, use the multiplier 2.

All limit switches have a recommended operating travel and for best performance should be installed within these limits. (1)

A	B	C	A	B	C
1°	0.0002 (0.005mm)	0.017 (0.43mm)	46°	0.305 (7.7mm)	0.719 (18.2mm)
2°	0.0006 (0.015mm)	0.035 (0.89mm)	47°	0.318 (8.1mm)	0.731 (18.6mm)
3°	0.0014 (0.035mm)	0.052 (1.3mm)	48°	0.331 (8.4mm)	0.743 (18.9mm)
4°	0.002 (0.05mm)	0.070 (1.8mm)	49°	0.344 (8.7mm)	0.755 (19.2mm)
5°	0.004 (0.101mm)	0.087 (2.2mm)	50°	0.357 (9.0mm)	0.766 (19.4mm)
6°	0.005 (0.127mm)	0.105 (2.6mm)	51°	0.371 (9.4mm)	0.777 (19.7mm)
7°	0.007 (0.178mm)	0.122 (3.1mm)	52°	0.384 (9.7mm)	0.788 (20.0mm)
8°	0.010 (0.254mm)	0.139 (3.5mm)	53°	0.398 (10.1mm)	0.799 (20.3mm)
9°	0.012 (0.304mm)	0.156 (4.0mm)	54°	0.412 (10.4mm)	0.809 (20.5mm)
10°	0.015 (0.381mm)	0.174 (4.4mm)	55°	0.426 (11.0mm)	0.819 (20.8mm)
11°	0.018 (0.457mm)	0.191 (4.8mm)	56°	0.441 (11.2mm)	0.829 (21.0mm)
12°	0.022 (0.559mm)	0.208 (5.3mm)	57°	0.455 (11.5mm)	0.839 (21.3mm)
13°	0.026 (0.660mm)	0.225 (5.7mm)	58°	0.485 (12.3mm)	0.857 (21.7mm)
14°	0.030 (0.762mm)	0.242 (6.1mm)	59°	0.485 (12.3mm)	0.857 (21.7mm)
15°	0.034 (0.863mm)	0.259 (6.6mm)	60°	0.500 (12.7mm)	0.866 (22mm)
16°	0.039 (0.990mm)	0.276 (7.2mm)	61°	0.515 (13.1mm)	0.875 (22.2mm)
17°	0.044 (1.12mm)	0.292 (7.4mm)	62°	0.531 (13.5mm)	0.883 (22.4mm)
18°	0.049 (1.24mm)	0.309 (7.8mm)	63°	0.546 (14.0mm)	0.891 (22.6mm)
19°	0.054 (1.37mm)	0.326 (8.3mm)	64°	0.562 (14.3mm)	0.899 (22.8mm)
20°	0.060 (1.52mm)	0.342 (8.7mm)	65°	0.577 (14.6mm)	0.906 (23.0mm)
21°	0.066 (1.67mm)	0.358 (9.1mm)	66°	0.593 15.0(mm)	0.914 (23.2mm)
22°	0.073 (1.85mm)	0.375 (9.5mm)	67°	0.609 15.5(mm)	0.921 (23.4mm)
23°	0.079 (2.00mm)	0.391 (9.9mm)	68°	0.625 (16.0mm)	0.927 (23.5mm)
24°	0.086 (2.2mm)	0.407 (10.3mm)	69°	0.642 (16.3mm)	0.934 (23.7mm)
25°	0.094 (2.38mm)	0.423 (10.7mm)	70°	0.658 (16.7mm)	0.940 (23.9mm)
26°	0.101 (2.56mm)	0.438 (11.1mm)	71°	0.674 (17.1mm)	0.946 (24.0mm)
27°	0.109 (2.77mm)	0.454 (11.5mm)	72°	0.691 (17.5mm)	0.951 (24.1mm)
28°	0.117 (2.9mm)	0.469 (12mm)	73°	0.708 (18.0mm)	0.956 (24.3mm)
29°	0.125 (3.17mm)	0.485 (12.3mm)	74°	0.724 (18.4mm)	0.961 (24.4mm)
30°	0.134 (3.40mm)	0.500 (12.7mm)	75°	0.741 (19.0mm)	0.966 (24.5mm)
31°	0.143 (3.6mm)	0.515 (13.1mm)	76°	0.758 (19.2mm)	0.970 (24.6mm)
32°	0.152 (3.9mm)	0.530 (13.4mm)	77°	0.775 (20.0mm)	0.974 (24.7mm)
33°	0.161 (4.1mm)	0.545 (14.0mm)	78°	0.792 (20.1mm)	0.978 (24.8mm)
34°	0.171 (4.3mm)	0.559 (14.2mm)	79°	0.809 (20.5mm)	0.982 (24.9mm)
35°	0.181 (4.6mm)	0.574 (14.6mm)	80°	0.826 (21.0mm)	0.985 (25.0mm)
36°	0.191 (4.8mm)	0.588 (15mm)	81°	0.844 (21.4mm)	0.988 (25.1mm)
37°	0.201 (5.1mm)	0.602 (15.3mm)	82°	0.861 (21.8mm)	0.990 (25.1mm)
38°	0.212 (5.4mm)	0.616 (15.6mm)	83°	0.878 (22.3mm)	0.993 (25.2mm)
39°	0.223 (5.7mm)	0.629 (16.0mm)	84°	0.895 (22.7mm)	0.995 (25.3mm)
40°	0.234 (6.0mm)	0.643 (16.3mm)	85°	0.913 (23.2mm)	0.996 (25.3mm)
41°	0.245 (6.2mm)	0.656 (16.6mm)	86°	0.930 (23.6mm)	0.9976 (25.3mm)
42°	0.257 (6.5mm)	0.669 (17.0mm)	87°	0.948 (24.0mm)	0.9986 (25.4mm)
43°	0.269 (6.8mm)	0.682 (17.3mm)	88°	0.965 (24.5mm)	0.9994 (25.4mm)
44°	0.281 (7.1mm)	0.695 (17.6mm)	89°	0.983 (25.0mm)	0.9999 (25.4mm)
45°	0.293 (7.4mm)	0.707 (18mm)	90°	1.000 (25.4mm)	1.000 (25.4mm)

(1) Refer to document SM444R1 for additional information regarding Cam speed and angles.

Lever Actuators

For limit switches with lever actuators, the actuating force should be applied as nearly perpendicular to the lever as practical and perpendicular to the shaft axis about which the lever rotates.

Lever Actuators

Correct

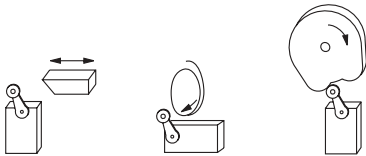

Incorrect

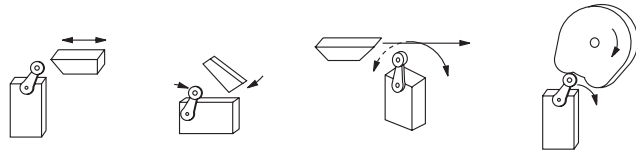

Dwelling Requirements

Where relatively fast motions are involved, the cams should be so designed that the limit switch will be held operated long enough to operate relays, valves, etc.

Correct

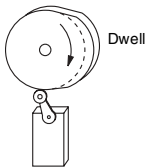

Incorrect

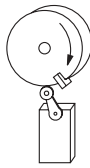

Overtravel limitations

Operating mechanisms for limit switches should be so designed that, under any operating or emergency conditions, the limit switch is not operated beyond its overtravel limit position. A limit switch should not be used as a mechanical stop.

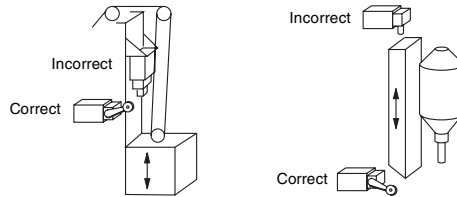

Correct

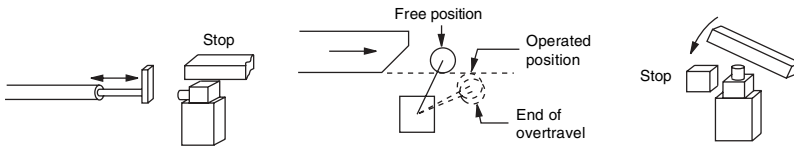



Schneider Electric worldwide

Up-dated: 28-07-2003

Afghanistan	Contacts are assured by	Schneider Electric India		
Albania	Contacts are assured by	Schneider Electric Austria		
Algeria	■ Schneider Electric	voie A Lot C22 Zone industrielle Rouiba - Alger	Tel.: +213 21 92 97 02 à 09 Fax: +213 21 92 97 00 à 01	
Andorra	Contacts are assured by	Schneider Electric France		
Angola	Contacts are assured by	Schneider Electric South Africa		
Anguilla	Contacts are assured by	Schneider Electric Dominican Rep.		
Antartica	Contacts are assured by	Schneider Electric Brazil		
Antigua & Barbuda	Contacts are assured by	Schneider Electric Dominican Rep.		
Argentina	■ Schneider Argentina	Viamonte 2850 - 1678 Caseros (provincia Buenos Aires)	Tel.: +54 1 716 88 88 Fax: +54 1 716 88 33	www.schneider-electric.com.ar
Armenia	Contacts are assured by	Schneider Electric Russian Fed.		
Aruba	Contacts are assured by	Schneider Electric Dominican Rep.		
Australia	■ Schneider Electric (Australia) Pty. Limited	2 Solent Circuit Norwest Business Park Baulkham Hill _ NSW 2153	Tel.: +61 298 51 28 00 Fax: +61 296 29 83 40	www.schneider.com.au
Austria	■ Schneider Austria Ges.m.b.H.	Birostrasse 11 1239 Wien	Tel.: +431 610 540 Fax: +431 610 54 54	www.schneider-electric.at
Azerbaijan	Contacts are assured by	Schneider Electric Russian Fed.		
Bahamas	■ Schneider Electric	Union Village PO Box 3901 - Nassau	Tel.: +1 242 327 42 91 Fax: +1 242 327 42 91	www.squared.com
Bahrain	■ Schneider Electric	Floor 1 - Juma Building Abu Horaira Avenue PO Box 355 - 304 Manama	Tel.: +97 322 7897 Fax: +97 321 8313	
Bangladesh	Contacts are assured by	Schneider Electric India		
Barbados	Contacts are assured by	Schneider Electric Dominican Rep.		
Belarus	■ Schneider Electric Industries SA	Prospect Macherova 5, of. 202 220004 Minsk	Tel.: +375 172 23 75 50 Fax: +375 172 23 97 61	
Belgium	■ Schneider Electric nv/sa	Dieweg 3 B - 1180 Brussels	Tel.: +3223737711 Fax: +3223753858	www.schneider-electric.be
Belize	Contacts are assured by	Schneider Electric USA		
Benin	Contacts are assured by	Schneider Electric Ivory Coast		
Bermuda	Contacts are assured by	Schneider Electric Dominican Rep.		
Bhutan	Contacts are assured by	Schneider Electric India		
Bolivia	Contacts are assured by	Schneider Electric Chile		
Bosnia and Herzegovina	Contacts are assured by	Schneider Electric Croatia		
Botswana	Contacts are assured by	Schneider Electric South Africa		
Bouvet island	Contacts are assured by	Schneider Electric Dominican Rep.		
Brazil	■ Schneider Electric Brazil Ltda.	Avenida Das Nações Unidas 23223 Jurubatuba - CEP 04795-907 São Paulo-SP	Tel.: +55 55 24 52 33 Fax: +55 55 22 51 34	www.schneider-electric.com.br
Brunei (Darussalam)	Contacts are assured by	Schneider Electric Singapore		
Bulgaria	■ Schneider Electric	Expo 2000, Boulevard Vapzarov 1407 Sofiav	Tel.: +3592 919 42 Fax: +3592 962 44 39	www.schneiderelectric.bg
Burkina Faso	Contacts are assured by	Schneider Electric Ivory Coast		
Burundi	Contacts are assured by	Schneider Electric Kenya		
Cambodia	Contacts are assured by	Schneider Electric Viet Nam		
Cameroon	■ Schneider Electric Cameroon	166, rue de l'Hôtel de Ville BP12087 - Douala	Tel.: +237 343 38 84 Fax: +237 343 11 94	
Canada	■ Schneider Canada	19, Waterman Avenue M4 B1Y2 Toronto - Ontario	Tel.: +1 416 752 8020 Fax: +1 416 752 4203	www.schneider-electric.ca
Cape Verde	Contacts are assured by	Schneider Electric Senegal		
Caribee	Contacts are assured by	Schneider Electric Dominican Rep.		
Cayman islands	Contacts are assured by	Schneider Electric Dominican Rep.		
Central African Republic	Contacts are assured by	Schneider Electric Cameroon		
Chad	Contacts are assured by	Schneider Electric Cameroon		
Chile	■ Schneider Electric Chile S.A.	Avda. Pöte Ed. Frei Montalva, 6001-31 Conchali - Santiago	Tel.: +56 2 444 3000 Fax: +56 2 423 9335	www.schneider-electric.co.cl
China	■ Schneider Beijing	Landmark bldg-Room 1801 8 North Dong Sanhuan Rd Chaoyang District 100004 Beijing	Tel.: +86 10 65 90 69 07 Fax: +86 10 65 90 00 13	www.schneider-electric.com.cn



Schneider Electric worldwide

Up-dated: 28-07-2003

Christmas island	Contacts are assured by	Schneider Electric Australia		
Cocos (Keeling) islands	Contacts are assured by	Schneider Electric Australia		
Colombia	■ Schneider Electric de Colombia S.A.	Calle 45A #102-48 Bogota DC	Tel.: +57 1 426 97 00 Fax: +57 1 426 97 40	
Comoros	Contacts are assured by	Schneider Electric la Reunion		
Congo	Contacts are assured by	Schneider Electric Cameroon		
Cook islands	Contacts are assured by	Schneider Electric Australia		
Costa Rica	■ Schneider Centroamérica Ltda.	1.5 kms oeste de la Embajada Americana, Pavas, San José, Costa Rica C.A. Apartado: 4123-1000 San Jose	Tel.: +506 232-60-55 Fax: +506 232-04-26	www.schneider-ca.com
Croatia	■ Schneider Electric SA	Fallerovo Setaliste 22 HR - 10000 Zagreb	Tel.: +385 1 367 100 Fax: +385 1 367 111	
Cuba	■ Schneider Electric	Bureau de Liaison de La Havane Calle 36- N°306-Apto1 Entre 3ra y 5ta Avenida Miramar Playa Habana	Tel.: +53 724 15 59 Fax: +53 724 12 17	
Cyprus	■ Schneider Electric Cyprus	28 General Timayia Avenue Kyriakos Building, Block #A301 Larnaca 6046	Tel.: +00357 248 12646 Fax: +00357 246 37382	
Czech Republic	■ Schneider Electric CZ, s.r.o.	Thámová 13 Praha 8 - 186 00	Tel.: +420 2 810 88 111 Fax: +420 2 24 81 08 49	www.schneider-electric.cz
Democratic Rep. of Congo	Contacts are assured by	Schneider Electric Cameroon		
Denmark	■ Schneider Electric A/S	Baltorpbakken 14 DK-2750 Ballerup	Tel.: +45 44 73 78 88 Fax: +45 44 68 5255	www.schneider-electric.dk
Djibouti	Contacts are assured by	Schneider Electric Egypt		
Dominican Republic	■ Schneider Electric	Calle Jacinto Manon Esq. Federico Geraldino Edificio D' Roca Plaza Suite 402, Ens. Paraiso - Santo Domingo	Tel.: +1 809 334 66 63 Fax: +1 809 334 66 68	
Ecuador	■ Schneider Electric Ecuador SA	Av.Republica del Salvador 1082 y Nac Edificio Mansion Blanca-Quito	Tel.: +593 2 224 42 42 Fax: +593 2 224 42 94	
Egypt	■ Schneider Electric Egypt sae	68, El Tayaran Street Nasr City, 11371 - Cairo	Tel.: +20 24 01 01 19 Fax: +20 24 01 66 87	www.schneider.com.eg
El Salvador	Contacts are assured by	Schneider Electric USA		
Equatorial Guinea	Contacts are assured by	Schneider Electric Cameroon		
Eritrea	Contacts are assured by	Schneider Electric Egypt		
Estonia	■ Lexel Electric	Ehitajate tee 110 EE 12618 Tallinn	Tel.: +372 650 97 00 Fax: +372 650 97 22	
Ethiopia	Contacts are assured by	Schneider Electric Egypt		
Falkland islands	Contacts are assured by	Schneider Electric Brazil		
Faroe islands	Contacts are assured by	Schneider Electric Australia		
Fiji	Contacts are assured by	Schneider Electric Australia		
Finland	■ Schneider Electric Oy	Sinimäentie 14 02630 Espoo	Tel.: +358 9 527 000 Fax: +358 9 5270 0376	www.schneider-electric.fi
France	■ Schneider Electric SA	5, rue Nadar 92500 Rueil Malmaison	Tel.: +33 (0)1 41 29 82 00 Fax: +33 (0)1 47 51 80 20	www.schneider-electric.fr
French Polynesia	Contacts are assured by	Schneider Electric Australia		
French West Indies	Contacts are assured by	Schneider Electric Dominican Rep.		
Gabon	Contacts are assured by	Schneider Electric Cameroon		
Gambia	Contacts are assured by	Schneider Electric Senegal		
Georgia	Contacts are assured by	Schneider Electric Russian Fed.		
Germany	■ Schneider Electric GmbH	Gothaer Straße 29 D-40880 Ratingen	Tel.: +49210 240 40 Fax: +492 10 240 49 256	www.schneiderelectric.de
Ghana	■ Schneider Electric Ghana	PMB Kia 3rd Floor Opeibea House Airport Commercial Center Liberation road - Accra	Tel.: +233 21 70 11 687 Fax: +233 21 77 96 22	
Gibraltar	Contacts are assured by	Schneider Electric Spain		
Greece	■ Schneider Electric AE	14th km - RN Athens-Lamia GR - 14564 Kifissia	Tel.: +302 106 29 52 00 Fax: +302 106 29 52 10	www.schneider-electric.com.gr
Greenland	Contacts are assured by	Schneider Electric United States		
Grenada	Contacts are assured by	Schneider Electric Dominican Rep.		
Guadeloupe	Contacts are assured by	Schneider Electric Martinique		
Guam	Contacts are assured by	Schneider Electric Australia		



Schneider Electric worldwide

Up-dated: 28-07-2003

Guatemala	Contacts are assured by	Schneider Electric United States		
Guinea-Bissau	Contacts are assured by	Schneider Electric Sénégal		
Guinea	Contacts are assured by	Schneider Electric Ivory Coast		
Guyana	Contacts are assured by	Schneider Electric United States		
Haiti	Contacts are assured by	Schneider Electric Dominican Rep.		
Heard & Mac Donald isl.	Contacts are assured by	Schneider Electric Australia		
Honduras	Contacts are assured by	Schneider Electric United States		
Hong Kong	■ Schneider Electric (Hong Kong) Ltd	Room 3108-28, 31th Floor, Sun Hung Kai Centre, 30 Harbour Road, Wanchai	Tel.: +852 25 65 06 21 Fax: +852 28 11 10 29	
Hungary	■ Schneider Electric Hungária Villamossági Rt.	Fehérvári út 108 – 112 H-1116 Budapest	Tel.: +36 1 382 26-06 Fax: +36 1 206 1429	www.schneider-electric.hu
Iceland	Contacts are assured by	Schneider Electric Denmark		
India	■ Schneider Electric India	Max House, 1 Dr Jha Marg, Okhla 110 020 New Dehli	Tel.: +91 11 631 85 84 Tel.: +91 11 631 71 61	www.schneiderelectric-in.com
Indonesia	■ P.T. Schneider Indonesia	Ventura Building 7th Floor Jalan R.A. Kartini Kav.26 Cilandak - 12430 Jakarta	Tel.: +62 +21 750 44 06 Fax: +62 +21 750 44 15/ 16	www.schneider-electric.co.id
Iran (Islamic Republic of)	■ Telemecanique Iran	1047 Avenue VALI ASSR P.O. Box 15875-3547 15116 Teheran	Tel.: +98 218 71 01 42 Fax: +98 218 71 81 87	
Irak	■ Schneider Electric Industries SA	38050 Grenoble Cedex 9	Tel.: +33 04 76 60 54 27 Fax: +33 04 76 60 56 60	
Ireland	■ Schneider Electric Ireland	Maynooth Road Cellbridge - Co. Kildare	Tel.: +353+0 1 6012200 Fax: +353+0 1 6012201	www.schneiderelectric.ie
Italy	■ Schneider Electric S.p.A.	Centro Direzionale Colleoni Palazzo Sirio - Viale Colleoni, 7 20041 Agrate Brianza (Mi)	Tel.: +39 39 655 8111 Fax: +39 39 605 6237	www.schneiderelectric.it
Ivory Coast	■ Schneider Electric Afrique de l'Ouest	Rue Pierre et Marie Curie 18 BP 2027 Abidjan 18	Tel.: +225 21 75 00 10 Fax: +225 21 75 00 30	
Jamaica	■ Schneider Electric	Shop#5, Plaza Dunrobin 30 Dunrobin Avenue - Kingstown	Tel.: +1876 755 41 27 Tel.: +931 87 74	
Japan	■ Schneider Electric Japan Ltd	Torigoe F. Bldg 1-8-2, Torigoe Taito-Ku - 111-0054 Tokyo	Tel.: +81 358 35 35 81 Fax: +81 358 35 35 85	www.schneider-electric.co.jp
Jordan	■ Schneider Electric Industr. Jordan	Jordan University Street Abu Al Haj Commercial Complex 2nd Floor - Office # 202 - Amman	Tel.: 962 65 16 78 87 Fax: 962 65 16 79 1	
Kazakstan	■ Schneider Electric Kazakhstan Liaison Office	Prospekt Abaia 157 off 9 480009 Almaty	Tel.: +7 327 250 93 88 Tel.: +7 327 250 63 70	
Kenya	■ Schneider East Africa	Power Technics Complex Monbasa Road - PO Box 46345 Nairobi	Tel.: +254 2.824.156 Fax: +254 2.824.157	
Kiribati	Contacts are assured by	Schneider Electric Australia		
Korea	■ Schneider Electric Korea Ltd	3Floor, Cheil Bldg., 94-46, 7-Ka Youngdeungpodong, Youngdeungpo-ku 150-037 Seoul	Tel.: +82 2 2630 9700 Fax: +82 2 2630 9800	www.csinfo.co.kr/schneider/
Kuwait	■ Schneider Electric Kuwait	Al Gaas Tower - Sharq 2nd Floor PO Box 20092 - 13 061 Safat	Tel.: +965 240 75 46 Fax: +965 240 75 06	
Kyrgyz Republic	Contacts are assured by	Schneider Electric Russian Fed.		
Laos	Contacts are assured by	Schneider Electric Thailand		
Latvia	■ Lexel Electric	60A A.Deglava str. LV1035 Riga	Tel.: +371 780 23 74/75 Fax: +371 754 62 80	
Lebanon	■ Schneider Electric Liban	Tabaris, Avenue Charles Malek Immeuble Ashada, 8 P.O. Box 166223 - Beyrouth	Tel.: +961 1 20 46 20 Tel.: +961 1 20 31 19	
Lesotho	Contacts are assured by	Schneider Electric South Africa		
Liberia	Contacts are assured by	Schneider Electric Ghana		
Libya	Contacts are assured by	Schneider Electric Tunisia		
Liechtenstein	Contacts are assured by	Schneider Electric Switzerland		
Lithuania	■ Lexel Electric	44, Verkiu str. LT-2012 Vilnius	Tel.: +370 278 59 59/61 Fax: +370 278 59 60	
Loro Sae	Contacts are assured by	Schneider Electric Australia		
Luxembourg	■ Schneider Electric Industrie SAS	Agence de Metz 1, Rue Graham Bell - BP n° 35190 57075 Metz cedex 3 - France	Tel.: 33 03 87 39 06 03 Fax: 33 03 87 74 25 96	www.schneider-electric.fr
Macau	Contacts are assured by	Schneider Electric China		



Schneider Electric worldwide

Up-dated: 28-07-2003

Macedonia	Contacts are assured by	Schneider Electric Bulgaria		
Madagascar	Contacts are assured by	Schneider Electric la Reunion		
Malawi	Contacts are assured by	Schneider Electric South Africa		
Malaysia	■ Schneider Electric (Malaysia) Sdn Bhd	No.11 Jalan U1/19, Seksyen U1 Hicom-Glenmarie Industrial Park 40150 Shah Alam Selangor Darul Ehsan	Tel. : (603) 7883 6333 Fax : (603) 7883 6188	www.schneider-electric.com.my
Maldives	Contacts are assured by	Schneider Electric Reunion		
Mali	Contacts are assured by	Schneider Electric Senegal		
Malta	Contacts are assured by	Schneider Electric Tunisia		
Marshall islands	Contacts are assured by	Schneider Electric Australia		
Martinique	■ Schneider Electric	Schneider Electric Immeuble Cottrell - ZI de la Lézarde 97232 Le Lamentin	Tel.: +05 96 51 06 00 Fax: +05 96 51 11 26	
Mauritania	Contacts are assured by	Schneider Electric Senegal		
Mauritius	■ Schneider Electric	Route côtière Calodyne - Mauritius	Tel.: 230 282 18 83 Fax: 230 282 18 84	
Mayotte	Contacts are assured by	Schneider Electric Reunion		
Mexico	■ Groupe Schneider Mexico	Calz. Rojo Gomez N° 1121-A Col. Guadalupe del Moral México, D.F. - C.P. 09300	Tel.: +525 686 30 00 Fax: +525 686 24 09	www.schneider-electric.com.mx
Micronesia	Contacts are assured by	Schneider Electric Australia		
Moldova	Contacts are assured by	Schneider Electric Romania		
Monaco	Contacts are assured by	Schneider Electric France		
Mongolia	Contacts are assured by	Schneider Electric Russian Fed.		
Montserrat	Contacts are assured by	Schneider Electric Dominican Rep.		
Morocco	■ Schneider Electric Morocco	26, rue Ibnou Khalikane Quartier Palmiers 20100 Casablanca	Tel.: +212 299 08 48 to 57 Fax: +212 299 08 67 and 69	www.schneider.co.ma
Mozambique	Contacts are assured by	Schneider Electric South Africa		
Myanmar	Contacts are assured by	Schneider Electric Singapore		
Namibia	Contacts are assured by	Schneider Electric South Africa		
Nauru	Contacts are assured by	Schneider Electric Australia		
Nepal	Contacts are assured by	Schneider Electric India		
Netherlands	■ Schneider Electric BV	Waarderweg 40 - Postbus 836 2003 RV Haarlem	Tel.: +31 23 512 4124 Fax: +31 23 512 4100	www.schneider-electric.nl
Netherlands Antilles	Contacts are assured by	Schneider Electric Dominican Rep.		
New Caledonia	Contacts are assured by	Schneider Electric Australia		
New Zealand	■ Schneider Electric (NZ) Ltd	14 Charann Place Avondale P.O. Box 15355 - New Lynn Auckland	Tel. : +64 9 829 04 90 Fax : +64 9 829 04 91	www.schneider-electric.co.nz
Nicaragua	Contacts are assured by	Schneider Electric United States		
Niger	Contacts are assured by	Schneider Electric Ivory Coast		
Nigeria	■ Schneider Electric Nigeria Limited	Biro plaza - 8th Floor - Plot 634 Abeyemo Alakija Street Victoria Islan - Lagos	Tel. : +234 1 2702973 Fax : +234 1 2702976	
Niue	Contacts are assured by	Schneider Electric Australia		
Norfolk island	Contacts are assured by	Schneider Electric Australia		
North Korea	Contacts are assured by	Schneider Electric China		
Northern Mariana islands	Contacts are assured by	Schneider Electric Australia		
Norway	■ Schneider Electric Norge A/S	Solgaard Skog 2 Postboks 128 - 1501 Moss	Tel.: +47 6924 9700 Fax: +47 6925 7871	www.schneider-electric.no
Oman	■ Schneider Electric CA	c/o Arab Development Co PO Box 439 - 113 Muscat	Tel.: +968 77 163 64 Fax: +968 77 104 49	
Pakistan	■ Schneider Electric Pakistan	43-L, 2nd floor, M.M. Alam Road, Gulberg II - Lahore	Tel.: +92 42 5754471 à 73 Fax: +92 42 5754474	
Palau	Contacts are assured by	Schneider Electric Australia		
Panama	Contacts are assured by	Schneider Electric United States		
Papua New Guinea	Contacts are assured by	Schneider Electric Australia		
Paraguay	Contacts are assured by	Schneider Electric Uruguay		
Peru	■ Schneider Electric Peru S.A.	Los Telares n°231 Urb. Vulcano, Ate Lima 03	Tel.: +511 348 44 11 Fax: +511 348 05 23	www.schneider-electric.com.pe



Schneider Electric worldwide

Up-dated: 28-07-2003

Philippines	■ Schneider Electric Philippines, Inc	5th Floor, ALCO Building 391 Sen, Gil Puyat Avenue Makati 1209	Tel.: +632 896 6063 Fax: +632 896 7229	
Pitcairn	Contacts are assured by	Schneider Electric Australia		
Poland	■ Schneider Electric Polska Sp.zo.o.	ul. Lubinowa 4a 03-878 - Warszawa	Tel.: +48 22 511 8 200 Fax: +48 22 511 8 210	www.schneider-electric.pl
Portugal	■ Schneider Electric Portugal	Av.do Forte, 3 Edificio Suécia II, Piso 3-A CP 2028 Carnaxide 2795 Linda-A-Velha	Tel.: +351 21 416 5800 Fax: +351 21 416 5857	www.schneiderelectric.pt
Puerto Rico	Contacts are assured by	Schneider Electric United States		
Qatar	■ Schneider Electric Qatar Branch	c/o Khalifa BinFahred Al Thani Trad.and Co - P.O. Box 4484 Doha	Tel.: +97 4424358 Fax: +97 4424358	
Reunion	■ Schneider Electric	Immeuble Futura, 190, rue des 2 canons BP 646 - 97497 Sainte Clothilde	Tel.: +262 28 14 28 Fax: +262 28 39 37	
Romania	■ Schneider Electric	Bd Ficusului n°42 Apimondia, Corp.A, et.1, Sector 1 Bucuresti	Tel.: +401 203 06 50 Fax: +401 232 15 98	www.schneider-electric.ro
Russian Federation	■ Schneider Electric ZAO	Enisseyskaya 37 129 281 Moscow	Tel.: +7095 797 40 00 Fax: +7095 797 40 03	www.schneider-electric.ru
Rwanda	Contacts are assured by	Schneider Electric Kenya		
Samoa	Contacts are assured by	Schneider Electric Australia		
San Marino	Contacts are assured by	Schneider Electric Italy		
Sandwich & Georgia island	Contacts are assured by	Schneider Electric Australia		
Sao Tome & Principe	Contacts are assured by	Schneider Electric Senegal		
Saudi Arabia	■ Schneider Electric	Second Industrial City P.O. Box 89249 - 11682 Riyadh	Tel.: +966 1 265 1515 Fax: +966 1 265 1860	
Senegal	■ Schneider Electric Sénégal	BP 15952 - Dakar-Fann Rond point N'Gor - Dakar	Tel.: +221 820 68 05 Fax: +221 820 58 50	
Seychelles	Contacts are assured by	Schneider Electric Reunion		
Sierra Leone	Contacts are assured by	Schneider Electric Ghana		
Singapore	■ Schneider Electric Singapore Pte Ltd	10 Ang Mo Kio Street 65 #02-17/20 TechPoint Singapore 569059	Tel.: +65 484 78 77 Fax: +65 484 78 00	www.schneider-electric.com.sg
Slovak Republic	■ Schneider Electric Slovakia spol s.r.o.	Borekova 10 SK-821 06 Bratislava	Tel.: +02 45 52 40 10 and 40 30 Fax: +02 45 52 40 00	www.schneider-electric.sk
Slovenia	■ Schneider Electric, d.o.o.	Dunasjka 47 1000 Ljubljana	Tel.: +386 1 23 63 555 Fax: +386 1 23 63 559	www.schneider-electric.si
Solomon islands	Contacts are assured by	Schneider Electric Australia		
Somalia	Contacts are assured by	Schneider Electric Egypt		
South Africa	■ Schneider Electric South Africa (PTY) Ltd	Private Bag X139 Halfway House 1685 - Midrand.	Tel.: +27 11 254 6400 Fax: +27 11 315 8830	www.schneider-electric.co.za
Spain	■ Schneider Electric España, S.A.	Pl. Dr. Letamendi, 5-7 08007 Barcelona	Tel.: +34 93 484 3100 Fax: +34 93 484 3308	www.schneiderelectric.es
Sri Lanka	■ Schneider Electric Industries SA	Liaison office SRI Lanka Level 3B Valiant towers 46/7 Nawam Mawatha-Colombo 2	Tel.: +94 77 48 54 89	www.schneiderelectric-in.com
St Helena	Contacts are assured by	Schneider Electric Italy		
St Kitts & Nevis	Contacts are assured by	Schneider Electric Dominican Rep.		
St Lucia	Contacts are assured by	Schneider Electric Dominican Rep.		
St Pierre et Miquelon	Contacts are assured by	Schneider Electric Dominican Rep.		
St Vincent & Grenadines	Contacts are assured by	Schneider Electric Dominican Rep.		
Sudan	Contacts are assured by	Schneider Electric Egypt		
Suriname	Contacts are assured by	Schneider Electric United States		
Svalbard & Jan Mayen isl.	Contacts are assured by	Schneider Electric Denmark		
Swaziland	Contacts are assured by	Schneider Electric South Africa		
Sweden	■ Schneider Electric AB	Djupdalsvägen 17/19 19129 Sollentuna	Tel.: +46 8 623 84 00 Fax: +46 8 623 84 85	www.schneider-electric.se
Switzerland	■ Schneider Electric (Switzerland) S.A.	Schermerwaldstrasse 11 CH - 3063 Ittigen	Tel.: +41 31 917 3333 Fax: +41 31 917 3355	www.schneider-electric.ch
Syrian Arab Republic	■ Schneider Electric Syria	Elba Street - Malki Gheibeh and Qassas bldg, 1st floor PO Box 33876-Damascus	Tel.: +963 11 37 49 88 00 Fax: +963 11 37 17 55 9	



Schneider Electric worldwide

Up-dated: 28-07-2003

Taiwan, Republic of China	■ Schneider Electric Taiwan Co Ltd	2Fl., N°37, Ji-Hu Road, Nei-Hu Dist., Taipei 114	Tel.: +886 2 8751 6388 Fax: +886 2 8751 6389	www.schneider-electric.com.tw
Tajikistan	Contacts are assured by	Schneider Electric Russian Fed.		
Tanzania, United Rep. of	Contacts are assured by	Schneider Electric Kenya		
Thailand	■ Schneider (Thailand) Ltd	20th Floor Richmond Building 75 Sukhumvit 26 Road, Klongtoey Bangkok 10110	Tel.: +662 204 9888 Fax: +662 204 9816	www.schneider-electric.co.th
Togo	Contacts are assured by	Schneider Electric Ivory Coast		
Tokelau	Contacts are assured by	Schneider Electric Australia		
Tonga	Contacts are assured by	Schneider Electric Australia		
Trinidad & Tobago	■ Schneider Electric	6, 1st Street West Ext. Beaulieu Avenue Trincity Trinidad West Indies	Tel.: 1868 640 42 04 Fax: 1868 640 42 04	
Tunisia	■ Schneider Electric Tunisia	Rue du Lac Oubeira 1053 Les Berges du Lac - Tunis	Tel.: +216 71 960 477 Fax: +216 71 960 342	
Turkey	■ Schneider Elektrik Sanayi Ve Ticaret A.S.	Tütüncü Mehmet Efendi Cad. N°:110 Kat 1-2 - 81080 Göztepe – Istanbul	Tel.: +90 21 63 86 95 70 Fax: +90 21 63 86 38 75	www.schneiderelectric.com.tr
Turkmenistan	■ Schneider Electric Turkmenistan Liaison Office	rue Neitralny Turkmenistan 28, off.326/327 74 000 Achgabad	Tel.: +993 12 46 29 52 Fax: +993 12 46 29 52	
Turks & Caicos islands	Contacts are assured by	Schneider Electric Dominican Rep.		
Tuvalu	Contacts are assured by	Schneider Electric Australia		
Uganda	Contacts are assured by	Schneider Electric Kenya		
Ukraine	■ Schneider Electric	Rue Krechtchalik 2 252601 Kiev	Tel.: +380 44 462 04 25 Fax: +380 44 462 04 24	www.schneider-electric.com.ua
United Arab Emirates	■ Schneider Electric Abu Dhabi	PO Box 29580 Office Floor 2/Lulu Street Al Marina Plaza Tower Abu Dhabi	Tel.: +9712 6 339444 Fax: +9712 6 316606	
United Kingdom	■ Schneider Electric Ltd	Braywick House East Windsor Road - Maidenhead Berkshire SL6 1 DN	Tel.: +44 (0)1 628 508 500 Fax: +44 (0)1 628 508 508	www.schneider.co.uk
United States	■ Schneider Electric	North American Division 1415 Roselle Road Palatine - IL 60067	Tel.: +1 847 397 2600 Fax: +1 847 925 7500	www.squared.com
Uruguay	■ Schneider Electric Uruguay S.A.	Ramon Masini 3190 Montevideo	Tel.: +59 82 707 2392 Fax: +59 82 707 2184	
Uzbekistan	Contacts are assured by	Schneider Electric Russian Fed.		
Vanuatu	Contacts are assured by	Schneider Electric Australia		
Vatican city St./Holy See	Contacts are assured by	Schneider Electric Italy		
Venezuela	■ Schneider Mg SD TE, S.A	Calle 162/ Piso 2 Edificio Centro Cynamid La Urbina, 1070 - 75319 Caracas	Tel.: +58 2 241 13 44 Fax: +58 2 243 60 09	www.schneider-electric.com.ve
Viet Nam	■ R.R.O. of Schneider Electric Industries S.A.S. in Viet Nam	Unit 2.9, 2nd Floor, e-Town Building 364 Cong Hoa Street Tan Binh District - Ho Chi Minh City	Tel.: +84 8 8103 103 Fax: +84 8 8120 477	
Virgin islands	Contacts are assured by	Schneider Electric Dominican Rep.		
Wallis & Futuna islands	Contacts are assured by	Schneider Electric Australia		
Western Sahara	Contacts are assured by	Schneider Electric Morocco		
Yemen	Contacts are assured by	Schneider Electric U.A.E.		
Yugoslavia	■ Schneider Electric Jugoslavija d.o.o.	Ratarski put 27d 11186 Belgrade	Tel.: +381 11 192 414 Fax: +381 11 107 125	
Zambia	■ Schneider Zambia	Zambia Office c/o Matipi Craft Center Building Plot 1036 - Accra Road PO Box 22792 - Kitwe	Tel.: +260 222 22 52 Fax: +260 222 83 89	
Zimbabwe	■ Schneider Electric	Zimbabwe Liaison Office 75A Second Street (corner Livingstone Avenue) Harare	Tel.: +263 4 707 179/180 Fax: +263 4 707 176	

Schneider Electric Industries SAS

Headquarters

89, bd Franklin Roosevelt
F - 92506 Rueil Malmaison Cedex

<http://www.schneider-electric.com>

Owing to changes in standards and equipment, the characteristics given in the text and images in this document are not binding until they have been confirmed with us.

Production : Schneider Electric Industries
Photos : Schneider Electric Industries
Printed by : CCI

9007CT0401

April 2004