

VA/F/K/K4/S and VU-8xx3-xxx-5-P Series

2½" ...6" Flanged, 2-Way and 3-Way Globe Valve Assemblies

Vx-8xx3 Series Balanced Plug Valve Assemblies

Schneider Electric VA, VF, VK, VK4, VS and VU-8xx3-xxx-5-P series valve assemblies are complete actuator/valve assemblies that accept two-position, floating, and proportional electric/electronic and proportional pneumatic control signals, for control of chilled water, hot water, or low pressure steam. These valve assemblies consist of pneumatic, electric, or electronic valve actuators either direct-coupled or linked to a 2½" ...6" 2-way or 3-way valve body with ASA flanged end connections.

VB-8xx3-0-5-P valve bodies are also available separately to allow field mounting of a variety of Forta, Schneider Electric SmartX® or pneumatic actuators using the appropriate linkage.

Features

- Balanced plug design provides high close-offs using economical actuation
- Up to 125 psi (856 kPa) close-off on 2-way models, 35 psi (240 kPa) on 3-way models
- Universal 3-way valve can be piped in either mixing or diverting configurations
- Valve sizes 2½" ...6", ASA 125 flanged
- A variety of Forta, Schneider Electric SmartX and pneumatic actuators are available, either as factory assemblies or for field assembly
- ANSI IV shutoff (0.01% of Cv) on 2-way models, ANSI III (0.1% of Cv) on 3-way models
- Self-adjusting spring loaded TFE/EPDM packing
- Normally open, normally closed, and non-spring return models available
- Expanded temperatures 20...281 °F
- ISO 9001:2000 Certified Quality Management System

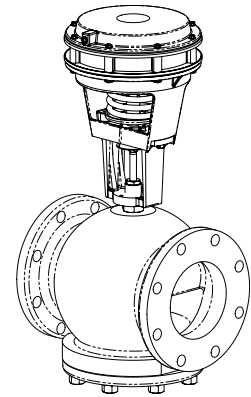

VK-82x3 with MK-6911

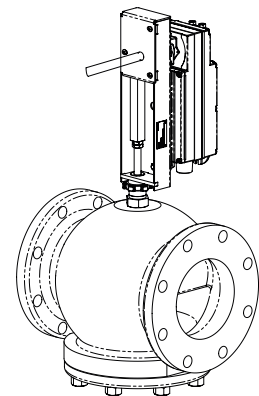

Vx-82x3 with Mx4x-6343

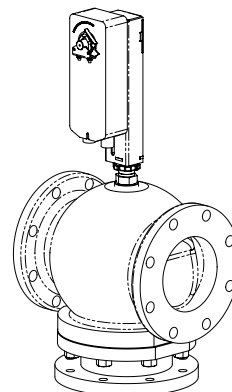

Vx-8303 with Mx4x-7xxx

Applicable Literature

F-Number	Description	Purpose	
F-26642	MA40-704x Series, MA4x-707x Series, MA4x-715x Series, SmartX Actuators Spring Return Two- Position General Instructions	Describes the actuators' features, specifications, wiring information and possible applications. Provides step-by- step mounting instructions.	
F-26644	MF40-7043, MF4x-7073 Series and MF4x-7153 Series General Instructions		
F-26742	MA40-717x SmartX Actuators Spring Return Two- Position General Instructions		
F-27120	MAx1-720x Two Position, MFx1-7103 Floating, and MSx1-7103 Proportional Series Linear SmartX Actuators General Instructions		
F-26744	MF41-6343 SmartX Actuators Non-Spring Return Floating General Instructions		
F-27599	M400, M800, and M1500 Series Schneider Electric Forta universal input Non-Spring Return actuator General Instructions		
F-26745	MS41-6343 SmartX Actuators Non-Spring Return Proportional General Instructions		
F-26749	MF40-7173 SmartX Actuators Spring Return Floating General Instructions		
F-13895	MK-6600 Series, MK-6800 Series, and MK-6911 General Instructions		
F-26645	MS40-7043, MS41-7073, MS41-7153 SmartX Actuators Spring Return Proportional General Instructions		
F-26748	MS40-7173 SmartX Actuators Spring Return Proportional General Instructions		
F-27683	M900 Series Forta Universal Spring Return Actuator General Instructions		
F-27479	AV-607-1, AV-609-1 SmartX Actuator Linkages for 2½" ...6" Globe Valves		Describes the linkage's features, specifications, and possible applications. Provides step-by- step mounting instructions.
F-27193	VB-8213 Series Valve Body General Instructions		
F-27194	VB-8223 Series Valve Body General Instructions		
F-27197	VB-8303 Series Valve Body General Instruction	Describes the valve body's features, specifications, and possible applications. Provides step-by-step mounting instructions.	
F-26080	EN-205 Water System Guidelines		
F-27855	North America Valves & Actuators Catalog	Describes all North America valves and actuators, ordering and dimension information.	

Product Guide Contents

3	Globe Valve Assembly Part Numbering System and Selection Procedure	24	Valve Assemblies with Mx40-717x Spring Return Electric SmartX Actuators
5	Electric and Pneumatic Actuators and Linkages	24	Actuator Specifications
8	Valve/Actuator Combinations and Operating Pressure Differentials	26	Valve Assemblies with MK-6811 and MK-6911 Spring Return Pneumatic Actuators
8	2 and 3-way Globe Valve Assemblies	26	Actuator Specifications
8	3-Way Electric Spring Return Models	27	System Design Considerations
9	3-Way Electric Non-Spring Return Models	27	Linked Globe Valve Assemblies
10	2-Way Electric Spring Return Models	27	Control Precision: 2-Way Valves
11	3-Way Electric Spring Return Models	27	3-Way Valves
12	2-Way Pneumatic Spring Return Models	28	Temperature/Pressure Ratings
13	3-Way Pneumatic Spring Return Models	28	Close-off Ratings
14	Actuator Specifications and Valve Assembly Mounting Dimensions	28	Installation Considerations
14	Valve Assemblies with MF41-6343 and MS41-6340, MS41-6341, and MS41-6343 Non-Spring Return Electric SmartX Actuators	28	Mounting Angle of Valve Assembly
14	Actuator Specifications	28	Insulation of Linked Globe Valve Assembly
16	Valve Assemblies with Schneider Electric Forta M900Axx (-S2) Series, U-Bolt Mounting Style Series, Spring Return 202 lbf Electric Linear Actuators	28	Temperature Limits for Globe Valve Assembly
16	Actuator Specifications	28	Sizing and Selection
18	Valve Assemblies with Schneider Electric Forta M1500A Series, U-Bolt Mounting Style Series, Non-Spring Return 337 lbf Electric Linear Actuators	28	Flow Coefficient (C _v)
18	Actuator Specifications	28	Two-position Control
20	Valve Assemblies with Mx61-720x Spring Return Linear Electric SmartX Actuators	28	Proportional Control
20	Actuator Specifications	29	Secondary Circuits with Small Booster Pumps
22	Valve Assemblies with Mx41-715x Spring Return Electric SmartX Actuators	29	3-Way Mixing Valves Used to Bypass Flow
22	Actuator Specifications	29	3-Way Mixing Valves Used to Blend Water Flows
		30	3-Way Diverting Valves

Globe Valve Assembly Part Numbering System and Selection Procedure

To select a globe valve assembly, choose the following:

Vx - 8xx3 - xxx-5 - xx

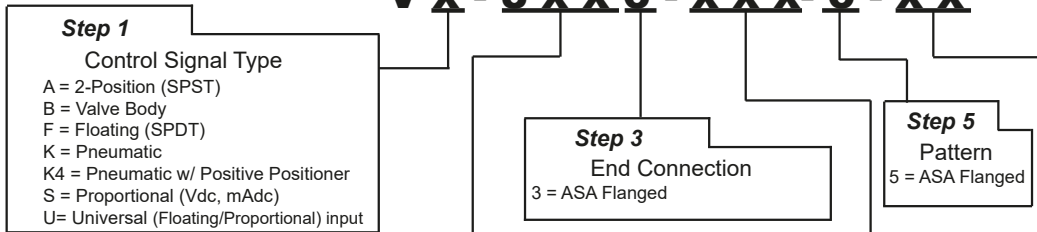

Step 1

Control Signal Type

- A = 2-Position (SPST)
- B = Valve Body
- F = Floating (SPDT)
- K = Pneumatic
- K4 = Pneumatic w/ Positive Positioner
- S = Proportional (Vdc, mAdc)
- U = Universal (Floating/Proportional) input

Step 3

End Connection
3 = ASA Flanged

Step 5

Pattern
5 = ASA Flanged

Step 2

Valve Body Configuration

- 821 = 2-Way Stem Up Open, Brass Trim
- 822 = 2-Way Stem Up Closed, Brass Trim
- 830 = 3-Way Mixing/Diverting, Brass Trim

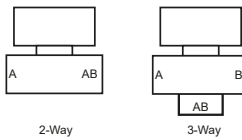

Valve Assemblies	Valve Body Action	Factory Shipped Position		Action (As actuator strokes & valve stem goes down)
		Valve Stem	Flow	
Vx-8213-xxx-5-P	2-Way Stem Up Open (Normally open if spring return actuator)	Up	Open	A to AB flow decreases
Vx-8223-xxx-5-P	2-Way Stem Up Closed (Normally Closed if spring return actuator)	Up	Closed	A to AB flow increases
Vx-8303-xxx-5-P	3-Way Mixing ^a (Normally stem up if spring return actuator)	Up	Flow B to AB	AB to B flow decreases AB to A flow increases
	3-Way Diverting ^a (Normally stem up if spring return actuator)	Up	Flow AB to B	B to AB flow decreases A to AB flow increases

^a May be piped as mixing (two inlets, one outlet) or diverting (one inlet, two outlets)

Step 4

Actuator Code

SmartX Electric Actuators

Code	Model	Spring Return	Code	Model	Spring Return
Two-Position			Proportional		
552	MA41-7150	Yes	512	MS41-6340	No
554	MA41-7151	Yes	514	MS41-6341	No
556	MA41-7153	Yes	516	MS41-6343	No
572	MA40-7170	Yes	556	MS41-7153	Yes
574	MA40-7171	Yes	572	MS40-7170	Yes
576	MA40-7173	Yes	574	MS40-7171	Yes
594	MA61-7201	Yes	576	MS40-7173	Yes
595	MA61-7200	Yes	596	MS61-7203	Yes
596	MA61-7203	Yes	Electric Actuators		
Floating			Universal		
516	MF41-6343	No	686	M1500A	No
556	MF41-7153	Yes	Pneumatic Actuators		
576	MF40-7173	Yes	602 ^a	MK-6811	Yes
596	MF61-7203	Yes	652 ^b	MK-6911	Yes

^a AK-42309-500 positive positioner recommended
^b AK-42309-500 positive positioner required

Step 6

Port Code

Size	2-Way		3-Way	
	Cv	P Code	Cv	P Code
2-1/2"	56	12	80 ^c	12
			95 ^d	
			115 ^e	
3"	85	13	110 ^c	13
			120 ^d	
			120 ^e	
4"	145	14	190 ^f	14
5"	240	15	290 ^f	15
6"	370	16	500 ^f	16

^c Mixing configuration, flow from either A or B to .

^d Diverting configuration, flow AB to A.

^e Diverting configuration, flow AB to B.

^f All flow configurations.

Note: Consult Table 1 and Tables 7 to 13 to confirm that the actuator/valve combination is feasible and that close-off and maximum differential pressures are suitable for the application.

Globe Valve Bodies

Table 1. Specifications for Globe Valve Bodies

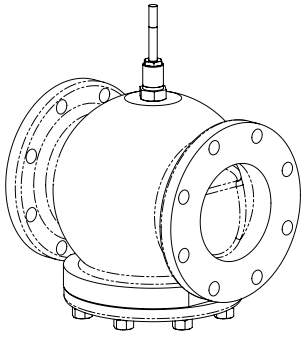
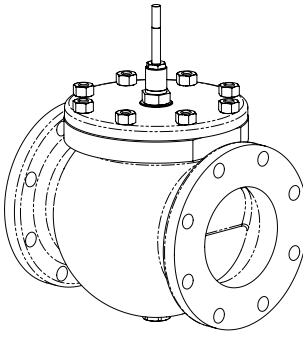
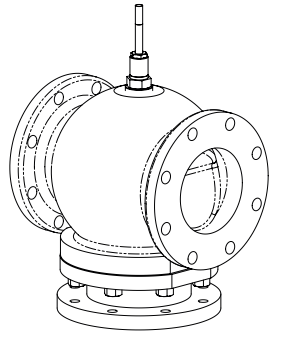
		Application				
		Chilled or Hot Water, Steam		Chilled or Hot Water		
		Flanged				
						
		VB-8213	VB-8223	VB-8303		
Size		2-1/2" to 6"		2-1/2" to 6"		
Valve Body		VB-8213-0-5-P		VB-8223-0-5-P		
Valve Body Action		2-Way Stem Open (Normally open if spring return actuator)		2-Way Stem Up Closed (Normally closed if spring return actuator)		
Material	Flow Type	Modified Equal %		Modified Equal %		
	Body	Cast Iron		Cast Iron		
	Seat	Forged Brass		Forged Brass		
	Stem	Stainless Steel		Stainless Steel		
	Plug	Forged Brass		Forged Brass		
	Packing	Spring Loaded TFE/EPDM		Spring Loaded TFE/EPDM		
	Seat Ring	EPDM		EPDM		None
ANSI Pressure Class, psig		125				
Maximum Inlet Pressure Steam psig (kPa)		35 (240)			—	
Allowable Control Media Temperature, °F (°C) ^b		20°F to 281°F (-7°C 138°C)				
Close-Off Pressure, psi (kPa)		125 (856) ^f			35 (240) ^c	
P Code	Valve Size, In.	Cv (kvs)		Cv (kvs) Mixing ^d	Cv (kvs) Diverting ^d	
12	2-1/2	56 (48)	56 (48)	80 (69)	95 (82) ^e 115 (99) ^f	
13	3	85 (74)	85 (74)	110 (95)	120 (104) ^g	
14	4	145 (125)	145 (125)	190 (164)	190 (164) ^g	
15	5	240 (208)	240 (208)	290 (251)	290 (251) ^g	
16	6	370 (320)	370 (320)	500 (433)	500 (433) ^g	

a - VB-8303 valves will also operate satisfactorily as two-way angle valves if either end (side) port is closed off.

b - CAUTION: Freeze protection required for temperatures below 32°F (0 °C). Avoid ice formation on stems.

c - Valve in closed position. See Table-9 to Table-14 for maximum allowable differential pressure for valve in any open position.

d - VB-8303 may be piped as either mixing or diverting, bottom (AB) port common.

e - Diverting configuration, flow AB to A ports.

f - Diverting configuration, flow AB to B ports.

g - All diverting flow configurations, flow AB to either A or B ports.

Electric and Pneumatic Actuators and Linkages

Table 2. Floating and Proportional Non-Spring Return Electric Schneider Electric Forta and Schneider Electric SmartX Actuators

Actuator Part Number	Actuator Code	Control Signal Type	Power Input @ 50/60 Hz				Timing, sec. ^a		Output Force or Torque	Manual Override
			Voltage	VA		Watts	50 HZ	60 HZ		
				Running	Holding					
M1500A ^b	686	Floating (SPDT)	24 Vac ±10% 20-30 Vdc	24 ^c	—	—	60 or 300 adj ^d		337 lb-in (1500 N)	Yes
		Proportional (Vdc or mAdc)					20 sec 1 ^e of stroke			
MF41-6343 ^f	516	Floating (SPDT)	24 Vac ±20%	5.7	4.1	3.9	162	162	300 lb-in (34 N-m)	
			22-30 Vdc	4.1	3.0	4.1				
MS41-6341 ^f	514	Proportional (Vdc or mAdc)	240 Vac ±10%	9.0	8.1	5.0	148	148	300 lb-in (34 N-m)	
MS41-6340 ^f	512	Proportional (Vdc or mAdc)	120 Vac ±10%	7.5	6.2	4.7	148	148	300 lb-in (34 N-m)	
MS41-6343 ^f	516	Proportional (Vdc or mAdc)	24 Vac ±10%	5.6	4.0	3.6	148	148	300 lb-in (34 N-m)	
			22-30 Vdc	3.4	2.2	3.4				

- a - Approximate timing @ 70°F (21°C) with no load.
- b - Requires AV-822 linkage, if field assembled.
- c - Requires a 50 VA transformer for sizing.
- d - For the floating control signal only.
- e - Proportional control.
- f - Actuator plus linkage is available as an assembly by adding -220 (AV-607-1 linkage) or -230 (AV-609-1 linkage) after the actuator number. Refer to Table -8 for a complete offering. Mx41-634x is not compatible with the AV-607-1 linkage

Table 3. Two-Position, Floating, and Proportional Spring Return Electric 220 lbf Linear SmartX Actuators

Actuator Part Number	Actuator Code	Control Signal Type	Power Input								Timing, sec. ^a		Output Force, lbf (N)	Manual Override
			Voltage 50/60 Hz	Running				DC Amp	Holding		Powered	Spring Return		
				50 Hz		60 Hz			50 Hz	60 Hz				
MA61-7200	595	2-Position (SPST or Triac)	120 Vac ±10%	11.7	8.8	10.0	8.4	—	3.6	5.0	<190	<40	220 (979) minimum 495 (2202) max. stall	Yes
MA61-7201	594		230 Vac ±10%	15.5	9.5	10.6	8.5	—	4.6	3.3				
MA61-7203	596		24 Vac ±20% 22-30 Vdc	9.8	7.5	9.7	7.5	0.29	2.8	2.8				
MF61-7203	596	Floating (SPDT)	24 Vac ±20% 22-30 Vdc	9.8	7.7	9.7	7.7	0.3	3.3	3.3				
MS61-7203	596	Proportional (Vdc or mAdc)	24 Vac ±20% 22-30 Vdc	9.8	7.4	9.7	7.4	0.28	2.9	2.9				

- a - Approximate timing @ 70°F (21°C) with no load.

Table 4. Two-Position, Floating and Proportional Spring Return Electric 133 lb-in SmartX Actuators

Actuator Part Number	Actuator Code	Control Signal Type	Power Input								Timing, sec. ^a		Torque, lb-in (N-m) ^b	Manual Override
			Voltage 50/60 Hz	Running				DC Amp	Holding		Powered	Spring Return		
				50 Hz		60 Hz			50 Hz	60 Hz				
MA41-7150 ^{cd}	552	2-Position (SPST)	120 Vac ±10%	11.7	8.8	10.0	8.4	—	3.6	5.0	<190	<30	133 (15)	Yes
MA41-7151 ^c	554		230 Vac ±10%	15.5	9.5	10.6	8.5	—	4.6	3.3				
MA41-7153 ^c	556		24 Vac ±20% 22-30 Vdc	9.8	7.5	9.7	7.5	0.29	2.8	2.8				
MF41-7153 ^c	556	Floating (SPDT)	24 Vac ±20% 22-30 Vdc	9.8	7.7	9.7	7.7	0.3	3.3	3.3				
MS41-7153 ^c	556	Proportional (Vdc or mAdc)	24 Vac ±20% 22-30 Vdc	9.8	7.4	9.7	7.4	0.3	2.9	2.9				

- a - Approximate timing @ 70°F (21°C) with no load.
- b - De-rating required for spring return actuators at low temperatures.
- c - Actuator plus linkage is available as an assembly by adding -220 (AV-607-1 linkage) or -230 (AV-609-1 linkage) after the actuator number. Refer to Table-8 for a complete offering.
- d - The CE Directive is not applicable to this model.

Table 5. Two-Position, Floating and Proportional Spring Return Electric 150 lb-in SmartX Actuators

Actuator Part Number	Actuator Code	Control Signal Type	Power Input @ 50/60 Hz				Approximate Timing, Seconds@ Approximate Timing, Seconds @ 70°F (21°C with no load)		Actuator Output Torque Rating, lb-in (N-m) ^a	Manual Override
			Voltage	VA		Running Watts	Powered	Spring Return		
				Running	Holding					
MA40-7170	572	2-Position (SPST)	120 Vac ±10%	8.4	6.6	6.2	162	72	150 (17)	No
MA40-7171	574		240 Vac ±10%	9.8	8.5	6.5				
MA40-7173	576		24 Vac ±20%	7.4	5.1	5.3				
			22-30 Vdc	5.0	3.0	5.0				
MF40-7173	576	Floating	24 Vac ±20%	8.1	5.3	5.8	147	65		
			22-30 Vdc	5.7	3.6	5.7				
MS40-7170	572	Proportional (Vdc or mAdc)	120 Vac ±10%	8.5	5.2	6.4				
MS40-7171	574		240 Vac ±10%	10.8	9.0	7.2				
MS40-7173	576		24 Vac ±20%	7.8	4.7	5.5				
			22-30 Vdc	5.6	2.5	5.0				

a - De-rating required for spring return actuators at low temperatures.

Table 6. Forta Universal Input, 202 lbf, Spring Return

Actuator Part Number ^a	Actuator Code	Control Signal Type	Power Input @ 50/60 Hz				Timing, Sec. ^b		Output Force	Manual Override
			Voltage	VA ^c		Watts	50 Hz	60 Hz		
				Running	Holding					
M900AR M900ARW	650 660	Floating (SPDT) Proportional (Vdc or mAdc)	24 Vac 20-30 Vdc	24 Va	6 Va	21	60 or 300 adj ^d .98 - 1.2" @ 20 Sec	202 lb-in (900 N)	Yes	

- a - Requires AV-822 linkage.
- b - Approximate timing @ 70°F (21°C with no load).
- c - Requires a 50 VA transformer for sizing.
- d - For floating control only.
- e - Proportional control.

Table 7. Proportional Spring Return Pneumatic Actuators

Actuator Part Number ^a	Actuator Code	Nominal Spring Range, psig (kPa) ^b	Effective Area, in ² (cm ²)
MK-6811	602	5 to 10 (34 to 69)	50 (323)
MK-6911 w/AK-42309-500	652	5 to 10 (34 to 69)	50 (323)

a - K-42309-500 Positive Positioner (order separately) optional for 2-1/2" to 5" valves, required for 6" valves. VK4 factory valve assemblies include positive positioner.

b - Field adjustable with positive positioner.

Table 8. Linkage Kits and Actuator/Linkage Assemblies for Field Assembly

2-1/2" to 5" 2-Way & 3-Way	MK-6811 ^b	AV-497	—
6" 2-Way & 3-Way	MK-6911 ^b		—
2-1/2" to 5" 2-Way and 3-Way (1" nominal stroke)	MA41-7150 MA41-7151 MA41-7153 MA40-7170 MA40-7171 MA40-7173 MF41-6343 ^a MF41-7153 MF40-7173	AV-607-1	MA41-7150-220 MA41-7151-220 MA41-7153-220 MA40-7170-220 MA40-7171-220 MA40-7173-220 MF41-7153-220 MF40-7173-220 MS41-7153-220 MS40-7170-220 MS40-7171-220 MS40-7173-220
			MA41-7150-220 MA41-7151-220 MA41-7153-220 MA40-7170-220 MA40-7171-220 MA40-7173-220 MF41-7153-220 MF40-7173-220 MS41-7153-220 MS40-7170-220 MS40-7171-220 MS40-7173-220
6" 2-Way & 3-Way (1-3/4" nominal stroke)	MS41-6340 ^a MS41-6341 ^a MS41-6343 ^a MS41-7153 MS40-7170 MS40-7171 MS40-7173	AV-609-1	
2-1/2" to 4" only 2-Way & 3-Way	M900AR, M900ARW M900AE, M900AEW	AV-822	—
2-1/2" to 6" 2-Way & 3-Way (1" nominal stroke)	M1500A	AV-822	—

a - Mx61-720x Actuators require no separate linkage. Mx41-634x is not compatible with AV-607-1.

b - AK-42309-500 (order separately) optional for 2-1/2" to 5" valve, required for 6" valve. VK4 valve assemblies include positive positioner.

Valve/Actuator Combinations and Operating Pressure Differentials

2 and 3-way Globe Valve Assemblies

Note: Choose a valve assembly with a maximum operating differential pressure capability sufficient for the application. Consult Table 1 for close-off pressure ratings. Not all actuator and valve body combinations are offered as factory assemblies.

3-Way Electric Spring Return Models

Table 9. 2-Way Globe Valve Assemblies with Electric Non-Spring Return Actuators

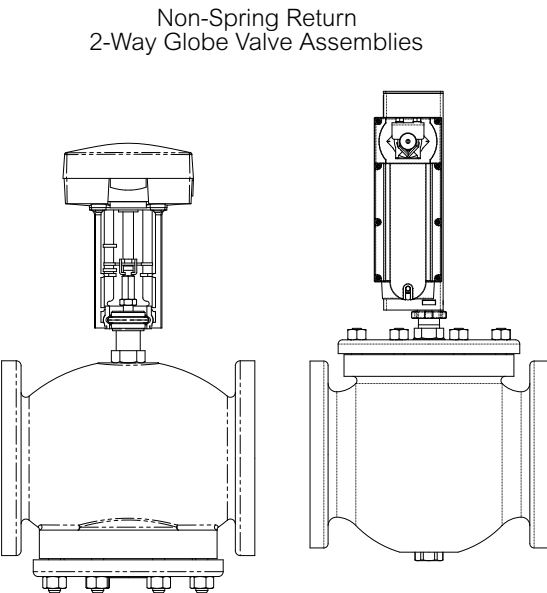
 <p>Non-Spring Return 2-Way Globe Valve Assemblies</p>					M1500A	Mx41-634x
					Actuator Output Rating (Minimum)	
Actuator Model (Actuator Code)			Floating MF41-6343 (516) Proportional MS41-6340 (512) MS41-6341 (514) MS41-6343 (516)			
Linkage Kit Part Number			AV-812 (2 1/2" to 6") AV-609-1 (6")			
Valve Assembly Part Number ^a	P Code	Valve Size in.	C _v ^b	k _{vs} ^b	Maximum Allowable Operating Differential Pressure ^c , psi (kPa)	
					Single Actuator	Dual Actuator ^d
Vx-8213-xxx-5-P Vx-8223-xxx-5-P	12	2-1/2	56	48	—	—
	13	3	85	74	—	—
	14	4	145	125	35 (240)	—
	15	5	240	208	—	—
	16	6	370	320	35 (240)	35 (240)

a - See Globe Valve Assembly Part Numbering System and Selection Procedure to determine a specific part number.

b - $k_{vs} = m^3/h$ ($\Delta P = 100$ kPa) $k_{vs} = C_v / 1.156$ $C_v = gpm / \sqrt{\Delta P}$ (in psi).

c - Maximum allowable differential across the valve in any open position. Less than 20 psi recommended for quieter service. Consult Table-1 on page 5 for close-off pressure ratings.

d - Dual actuators are not available as a factory assembly.

3-Way Electric Non-Spring Return Models

Table 10. 3-Way Globe Valve Assemblies with Electric Non-Spring Return Actuators

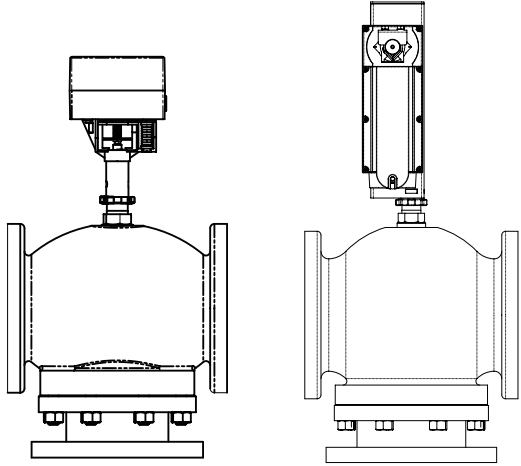
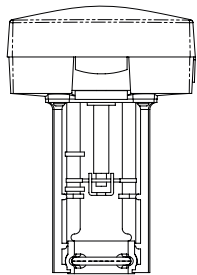
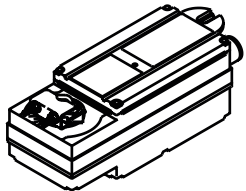
Non-Spring Return 3-Way Globe Valve Assemblies 					M1500A	Mx41-634x	
							
Actuator Output Rating (Minimum)							
		337 lbf (1500 N)	300 lb-in (34 N-m)				
Actuator Models (Actuator Codes)							
Floating/Proportional M1500A (686)		Floating MF41-6343 (516) Proportional MS41-6340 (512) MS41-6341 (514) MS41-6343 (516)					
Linkage Kit Part Number							
		AV-812 (2 1/2" to 6")	AV-609-1 (6")				
Valve Assembly Part Number ^a	P Code	Valve Size in.	C _v ^b	k _{vs} ^b	Maximum Allowable Operating Differential Pressure ^c , psi (kPa) (Mixing/Diverting)		
						Single Actuator	Dual Actuator ^d
Vx-8303-xxx-5-P	12	2-1/2	80 ^e	69 ^e	35 (240)	—	—
			95 ^f	82 ^f			
			115 ^g	99 ^g			
	13	3	110 ^e	95 ^e			
			120 ^f	104 ^f			
			120 ^g	104 ^g			
			14	4			
15	5	290 ^h	251 ^h				
16	6	500 ^h	433 ^h	32 (219) 28 (192)	35 (240)		

- a - See Globe Valve Assembly Part Numbering System and Selection Procedure to determine a specific part number.
- b - $k_{vs} = m^3/h (\Delta P = 100 \text{ kPa})$ $k_{vs} = C_v / 1.156$ $C_v = \text{gpm} / \sqrt{\Delta P}$ (in psi).
- c - Maximum allowable differential across the valve in any open position. Less than 20 psi recommended for quieter service. Consult Table-1 on page 5 for close-off pressure ratings.
- d - Dual actuators are not available as a factory assembly.
- e - Mixing configuration, ports A and B are inlets, AB port is outlet.
- f - Diverting configuration, flow AB to A port.
- g - Diverting configuration, flow AB to B port.
- h - All flow configurations, mixing or diverting.

2-Way Electric Spring Return Models

Table 11. 2-Way Globe Valve Assemblies with Electric Spring Return Actuators

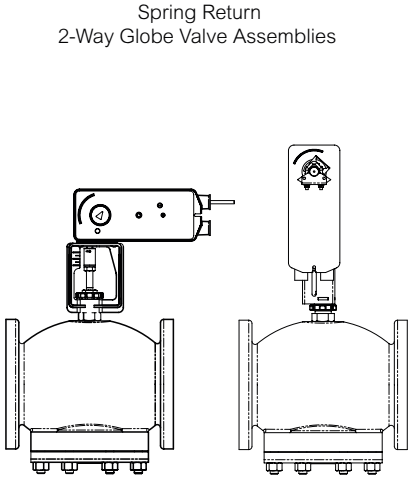
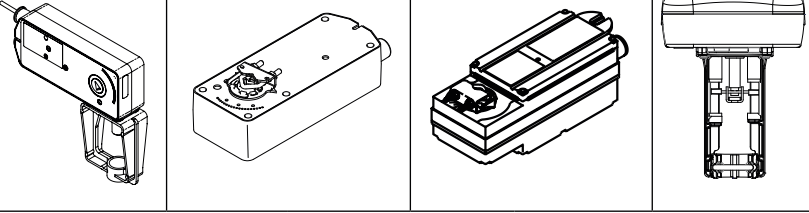
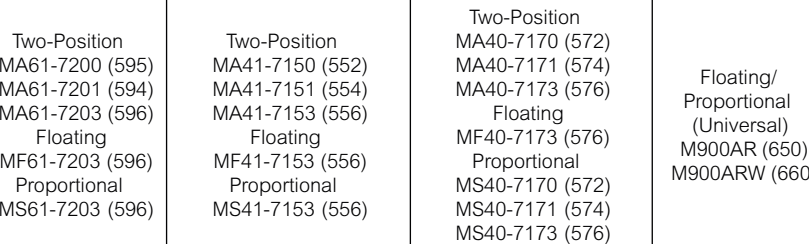
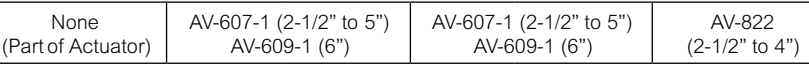
 <p>Spring Return 2-Way Globe Valve Assemblies</p>					Mx61-720x	Mx41-715x	Mx40-717x	M900Axx (-S2) ^a						
										Actuator Output Rating (minimum)				
					220 lbf (979 N)		133 lb-in (15 N-m)		150 lb-in (17 N-m)		202 lbf-in (900 N)			
										Actuator Models (Actuator Codes)				
					Two-Position MA61-7200 (595) MA61-7201 (594) MA61-7203 (596) Floating MF61-7203 (596) Proportional MS61-7203 (596)		Two-Position MA41-7150 (552) MA41-7151 (554) MA41-7153 (556) Floating MF41-7153 (556) Proportional MS41-7153 (556)		Two-Position MA40-7170 (572) MA40-7171 (574) MA40-7173 (576) Floating MF40-7173 (576) Proportional MS40-7170 (572) MS40-7171 (574) MS40-7173 (576)		Floating/ Proportional (Universal) M900AR (650) M900ARW (660)			
										Linkage Kit Part Number				
None (Part of Actuator)		AV-607-1 (2-1/2" to 5") AV-609-1 (6")		AV-607-1 (2-1/2" to 5") AV-609-1 (6")		AV-822 (2-1/2" to 4")								
Valve Assembly Part Number ^b	P Code	Valve Size in.	C _v ^c	k _{vs} ^b	Maximum Allowable Operating Differential Pressure ^d , psi (kPa)									
						Single Actuator	Dual Actuator ^e	Single Actuator	Dual Actuator ^d	Single Actuator				
Vx-8213-5xx-5-P Vx-8223-5xx-5-P	12	2-1/2	56	48	35 (240)	35 (240)	—	35 (240)	—	35 (240)				
	13	3	85	74										
	14	4	145	125										
	15	5	240	208										
	16	6	370	320	—	22 (151)	35 (240)	25 (171)	35 (240)	—				

a - S2 auxiliary switches may be added in the field. Order 880 0104 000.

b - See Globe Valve Assembly Part Numbering System and Selection Procedure to determine a specific part number.

c - $k_{vs} = m^3/h (\Delta P = 100 \text{ kPa})$ $k_{vs} = C_v / 1.156$ $C_v = \text{gpm} / \sqrt{\Delta P}$ (in psi).

d - Maximum allowable differential across the valve in any open position. Less than 20 psi recommended for quieter service. Consult Table-1 for close-off pressure ratings.

e - Dual actuators are not available as factory assemblies.

3-Way Electric Spring Return Models

Table 12. 3-Way Globe Valve Assemblies with Electric Spring Return Actuators

<p>Spring Return 3-Way Globe Valve Assemblies</p>					Mx61-720x	Mx41-715x	Mx40-717x	M900Axx (-S2) ^a			
					Actuator Output Rating (minimum)						
					220 lbf (979 N)	133 lb-in (15 N-m)	150 lb-in (17 N-m)	202 lbf-in (900 N)			
					Actuator Models (Actuator Codes)						
					Two-Position MA61-7200 (595) MA61-7201 (594) MA61-7203 (596) Floating MF61-7203 (596) Proportional MS61-7203 (596)	Two-Position MA41-7150 (552) MA41-7151 (554) MA41-7153 (556) Floating MF41-7153 (556) Proportional MS41-7153 (556)	Two-Position MA40-7170 (572) MA40-7171 (574) MA40-7173 (576) Floating MF40-7173 (576) Proportional MS40-7170 (572) MS40-7171 (574) MS40-7173 (576)	Floating/ Proportional (Universal) M900AR (650) M900ARW (660)			
					Linkage Kit Part Number						
None (Part of Actuator)	AV-607-1 (2-1/2" to 5") AV-609-1 (6")	AV-607-1 (2-1/2" to 5") AV-609-1 (6")	AV-822 (2-1/2" to 4")								
Valve Assembly Part Number ^b	P Code	Valve Size in.	C _v ^c	k _{vs} ^c	Maximum Allowable Operating Differential Pressure ^d , psi (kPa) (Mixing/Diverting)						
					Single Actuator	Dual Actuator ^e	Single Actuator	Dual Actuator ^d	Single Actuator		
Vx-8303-5xx-5-P	12	2-1/2	80 ^f	69 ^f	35 (240)/ 35 (240)	35 (240)	—	35 (240)/ 35 (240)	—	35 (240)/ 35 (240)	
			95 ^g	82 ^g							
			115 ^h	99 ^h							
	13	3	110 ^f	95 ^f		35 (240)/ 35 (240)	35 (240)	—	35 (240)/ 35 (240)	—	35 (240)/ 35 (240)
			120 ^g	104 ^g							
			120 ^h	104 ^h							
14	4	190 ^f	164 ^f	35 (240)/ 35 (240)	32 (219)/ 28 (192)		35 (240)/ 35 (240)	35 (240)/ 31 (212)	35 (240)/35 (240)	—	
15	5	290 ^f	251 ^f								
16	6	500 ^f	433 ^f								—

a - S2 auxiliary switches may be added in the field. Order 880 0104 000.

b - See Globe Valve Assembly Part Numbering System and Selection Procedure to determine a specific part number.

c - $k_{vs} = m^3/h (\Delta P = 100 \text{ kPa})$ $k_{vs} = C_v / 1.156$ $C_v = \text{gpm} / \sqrt{\Delta P}$ (in psi).

d - Maximum allowable differential across the valve in any open position. Less than 20 psi recommended for quieter service.
Consult Table-1 for close-off pressure ratings.

e - Dual actuators are not available as factory assemblies.

f - Mixing configuration, ports A and B are inlets, AB port is outlet.

g - Diverting configuration, flow AB to A port.

h - Diverting configuration, flow AB to B port.

i - All flow configurations, mixing or diverting.

2-Way Pneumatic Spring Return Models

Table 13. 2-Way Globe Valve Assemblies with Pneumatic Spring Return Actuators

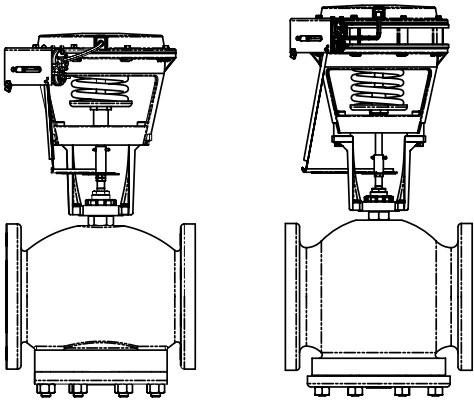
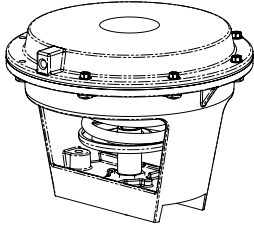
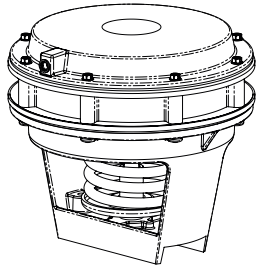
Spring Return					MK-6811 ^b	MK-6911 ^b
2-Way Globe Valve Assemblies						
						
					Actuator Models (Actuator Codes)	
					MK-6811 (602)	MK-6911 (652)
					Linkage Kit Part Number	
					AV-497	AV-497
					Spring Range, psig (kPa)	
					5 to 10 (34 to 69) ^a	5 to 10 (34 to 69) ^a
Valve Assembly Part Number ^b	P Code	Valve Size in.	C _v ^c	k _{vs} ^c	Maximum Allowable Operating Differential Pressure ^d , psi (kPa)	
VK-8213-602-5-12 VK-8223-602-5-12 VK4-8213-602-5-12 VK4-8223-602-5-12	12	2-1/2	56	48	35 (240)	—
VK-8213-602-5-13 VK-8223-602-5-13 VK4-8213-602-5-13 VK4-8223-602-5-13	13	3	85	74		—
VK-8213-602-5-14 VK-8223-602-5-14 VK4-8213-602-5-14 VK4-8223-602-5-14	14	4	145	125		—
VK-8213-602-5-15 VK-8223-602-5-15 VK4-8213-602-5-15 VK4-8223-602-5-15	15	5	240	208		—
VK4-8213-652-5-16 VK4-8223-652-5-16	16	6	370	320	—	35 (240)

a - Spring range field adjustable with positive positioner.

b - AK-42309-500 positive positioner optional for 2-1/2" to 5" valve, required for 6" valve. Supplied as standard on VK4 factory valve assemblies. See Globe Valve Assembly Part Numbering System and Selection Procedure to determine a specific part number.

c - $k_{vs} = m^3/h (\Delta P = 100 \text{ kPa})$ $k_{vs} = C_v / 1.156$ $C_v = \text{gpm} / \sqrt{\Delta P}$ (in psi).

d - Maximum allowable differential across the valve in any open position. Less than 20 psi recommended for quieter service. Consult Table-1 for close-off pressure ratings.

3-Way Pneumatic Spring Return Models

Table 14. 3-Way Globe Valve Assemblies with Pneumatic Spring Return Actuators

Spring Return 3-Way Globe Valve Assemblies					MK-6811 ^b		MK-6911 ^b	
					Actuator Models (Actuator Codes)		Actuator Models (Actuator Codes)	
					MK-6811 (602)		MK-6911 (652)	
					Linkage Kit Part Number		Linkage Kit Part Number	
					AV-497		AV-497	
					Spring Range, psig (kPa)		Spring Range, psig (kPa)	
					5 to 10 (34 to 69) ^a		5 to 10 (34 to 69) ^a	
Valve Assembly Part Number ^b	P Code	Valve Size in.	C _v ^c	k _{vs} ^c	Maximum Allowable Operating Differential Pressure ^d , psi (kPa) (Mixing/Diverting)			
VK-8303-602-5-12	12	2-1/2	80 ^e	69 ^e	35 (240)/ 35 (240)			
			95 ^f	82 ^f				
			115 ^g	99 ^g				
VK-8303-602-5-13	13	3	110 ^e	95 ^e			35 (240)/ 35 (240)	—
			120 ^f	104 ^f				
			120 ^g	104 ^g				
VK-8303-602-5-14	14	4	190 ^h	164 ^h	35 (240)/ 35 (240)	—		
VK-8303-602-5-15 VK4-8303-602-5-15	15	5	290 ^h	251 ^h				
VK4-8303-652-5-16	16	6	500 ^h	433 ^h				

a - Spring range field adjustable with positive positioner.

b - AK-42309-500 positive positioner optional for 2-1/2" to 5" valve, required for 6" valve. Supplied as standard on VK4 factory valve assemblies. See Globe Valve Assembly Part Numbering System and Selection Procedure to determine a specific part number.

c - $k_{vs} = m^3/h (\Delta P = 100 \text{ kPa})$ $k_{vs} = C_v / 1.156$ $C_v = \text{gpm} / \sqrt{\Delta P}$ (in psi).

d - Maximum allowable differential across the valve in any open position. Less than 20 psi recommended for quieter service. Consult Table-1 for close-off pressure ratings.

e - Mixing configuration, ports A and B are inlets, AB port is outlet.

f - Diverting configuration, flow AB to A port.

g - Diverting configuration, flow AB to B port.

h - All flow configurations, mixing or diverting.

Actuator Specifications and Valve Assembly Mounting Dimensions

Valve Assemblies with MF41-6343 and MS41-6340, MS41-6341, and MS41-6343 Non-Spring Return Electric SmartX Actuators

Actuator Specifications

Inputs	
Control Signal	SPDT Floating Control, Triacs (500 mA rated), or 2 SPST contacts
MF41-6343	
MS41-634x	Proportional, 2 to 10 Vdc or 4 to 20 mAdc with the addition of a 500 ohm resistor (not included)
Power Requirements	All 24 Vac and 22-30 Vdc circuits are Class 2 All circuits 30 Vac and above are Class 1
Connections	
Class 1 Power	24 inch (61 cm) long appliance cables; 18 AWG color coded leads,
Class 2 Power & Control	36 inch (91 cm) long, 22 AWG appliance cable color coded leads 1/2" conduit connector. For M20 metric conduit, use AM-756 Adapter.
Motor Type	Brushless DC
Outputs	
Electrical	
Stroke	Proportional models electronically limited to a maximum of 92 ±1°; floating model mechanically limited to 101° ±1°.
Mechanical	
Timing	Approximate timing is 148 sec. for proportional models; 162 sec. for floating models
Manual Override	Activated by the manual override crank

Output torque rating	300 lb-in (34 N-m) minimum
Position indicator	Pointer and scale are provided for position indicator.
Environmental	
Temperature Limits	
Shipping and storage	-40 to 160 °F (-40 to 71 °C) ambient
Operating	-25...140 °F (-32...60 °C) ambient temperature.
Maximum allowable ambient	124 °F (51 °C) at maximum valve fluid temperature of 281 °F (138 °C). Minimum allowable valve fluid temperature 20 °F (-7 °C)
Humidity	5 to 95% RH, non-condensing
Enclosure Rating	NEMA Type 1 (IEC IP30), NEMA Type 4 (IEC IP56) with customer-supplied water tight conduit connectors
Agency Listings (Actuator)	
UL	UL 873, Underwriters Laboratories (File # E9429 Category Temperature-Indicating and Regulating Equipment)
European Community	EMC Directive (2004/108/EC) Low Voltage Directive (72/23/EEC)
cULus	EMC Directive (2004/108/EC) Low Voltage Directive (72/23/EEC)
Australia	This product meets requirements to bear the RSM Mark according to the terms specified by the Communications Authority under the Radiocommunications Act 1992

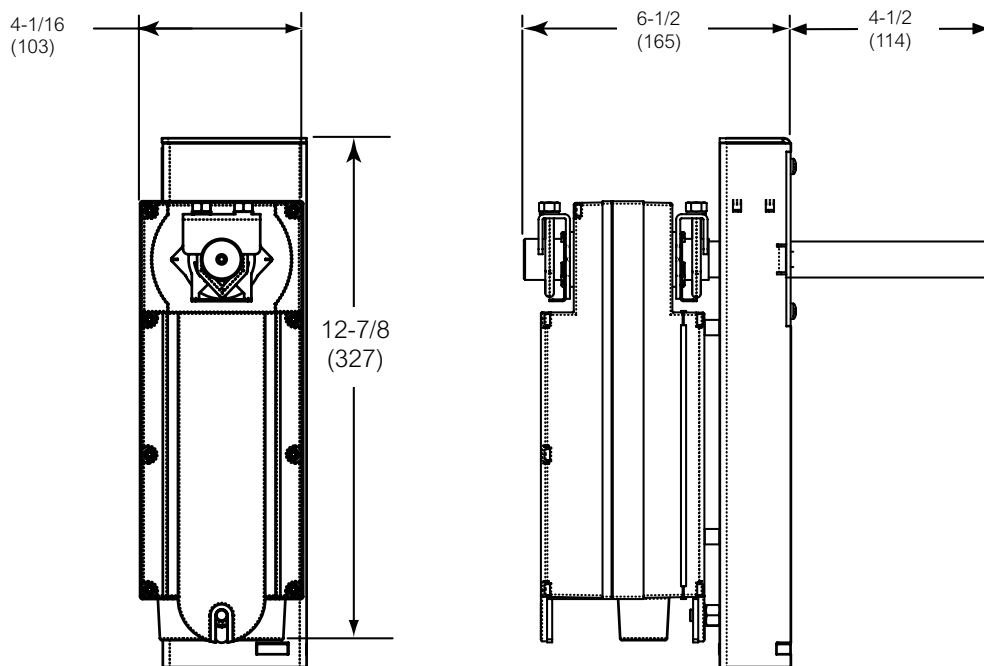

Figure 1 Mx41-634x-230 Actuator/Linkage Assembly

Dimensions - 6" Flanged Globe Valve Assemblies

Valve Assembly Part Number	Valve Size	Valve Dimensions in inches (mm)											
		2-Way (Refer to Figure 2)						3-Way (Refer to Figure 3)					
		A	C	E	F	G	H	A	C	E	F	G	H
2-Way Vx-8213-51x-5-16 3-Way Vx-8303-51x-5-16	6"	14 (356)	7½ (190)	19-15/16 (507)	11 (280)	9½ (241)	12 (305)	14 (356)	9-3/4 (248)	20¼ (515)	11 (280)	9½ (241)	12 (305)
2-Way Vx-8223-516-5-16	6"	14 (356)	6¼ (159)	21-3/8 (543)	11 (280)	9½ (241)	12 (305)	—	—	—	—	—	—

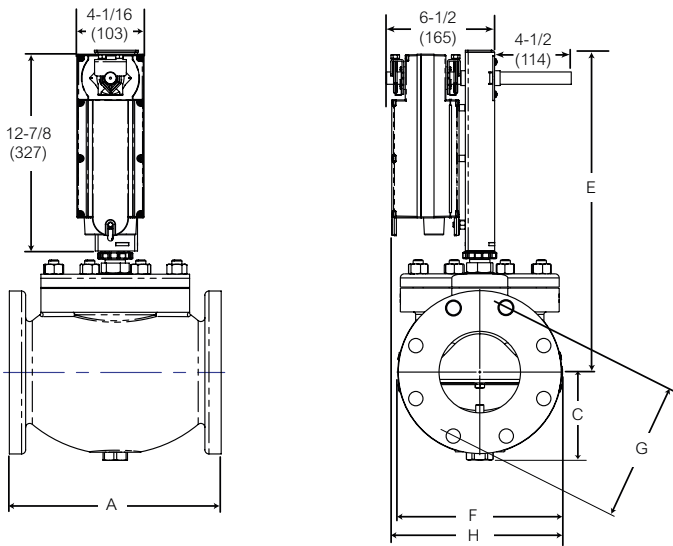

Figure 2 Mx41-634x with 6" Flanged 2-Way Globe Valves

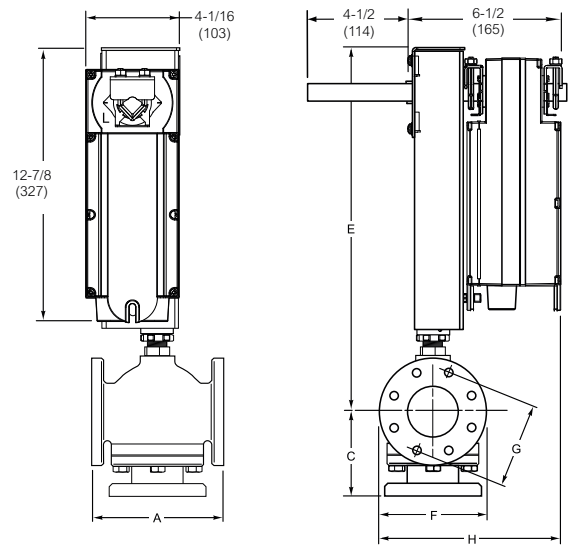

Figure 3 Mx41-634x with 6" Flanged 3-Way Globe Valves

Valve Assemblies with Schneider Electric Forta M900Axx (-S2) Series, U-Bolt Mounting Style Series, Spring Return 202 lbf Electric Linear Actuators

Actuator Specifications

Inputs	
Control Signal	M900AR/M900ARW (Spring Return UP) M900AE/M900AEW (Spring Return Down): Universal input signal, including floating, 0-10 Vdc, 2-10 Vdc, or 4-20 mA with 500 ohm resistor (included), reverse and direct acting, and proportional sequencing input signal ranges
Power Requirements	
Voltage	24 Vac ±10% @ 50/60 Hz, 20-30 Vdc
Power Input	24 VA running, 50 VA transformer sizing
Connections	Screw terminals; conduit knockouts
Motor Type	Brushless DC
Outputs	
Electrical	2...10 Vdc feedback
Auxiliary switch	Available on M900AxW-S2. Rated 2A @ 24 Vac. 2 SPDT Rated 4A @24 Vac S2 models available from factory need to be field assembled onto valve bodies
Mechanical	
Output force rating	202 lbf (900 N) minimum
Timing	Floating 60 or 300 seconds, Proportional 20 seconds @ 1" stroke

Position indicator	Provided
Manual Override	Activated by the manual override crank
Linear stroke	The stroke is 2" maximum, the input control signal requires a minimum 3/8" (9 mm) travel and a maximum 1.25" (31.75mm) travel anywhere with in the 2" (52 mm) stroke window.
Environmental	
Temperature Limits	
Shipping and storage	-13...149 °F (-25...65 °C) ambient
Operating	Temperature at maximum valve fluid temperature, of: 14...122 °F (-10 to 50 °C), 55 °F (13 °C) 14...113 °F (-10 to 45 °C), 281 °F (138 °C) 14...107 °F (-10 to 42 °C), 300 °F (149 °C) 14...100 °F (-10 to 38 °C), 340 °F (171 °C) 14...90 °F (-10 to 32 °C), 366 °F (171 °C)
Humidity	5 to 95% RH, non-condensing
Enclosure Rating	
M900Ax NEMA 2 or M900AxW	NEMA 4 with all conduit connectors used and vertically mounted
Agency Listings (Actuator)	
cULus	UL 873, Underwriters Laboratories (File # E9429 Category Temperature-Indicating and Regulating Equipment)
European Community	EMC Directive (89/336/EEC)

Dimensions - 2½"...4" Flanged Globe Valve Assemblies

Valve Assembly Part Number	Valve Size	P Code	Valve Dimensions in inches (mm)										
			2-Way					3-Way					
			A	C	E ^a	F	G	A	C	E ^a	F	G	
VU-8213-650-5-P	2½"	12	8-9/16 (217)	4 (102)	14-23/32 (374)	7 (178)	5½ (140)						
	3"	13	9½ (241)	4-5/8 (117)	15-11/32 (390)	7½ (191)	6 (152)						
	4"	14	11½ (292)	5-1/12 (140)	15-7/32 (412)	9 (229)	7½ (191)						
VU-8303-650-5-P	2½"	12							8-9/16 (217)	5-7/16 (138)	15-5/32 (410)	7 (178)	5½ (140)
	3"	13							9½ (241)	6-3/8 (162)	17-3/32 (434)	7½ (191)	6 (152)
	4"	14							11½ (292)	8-7/16 (214)	19-5/32 (487)	9 (229)	7½ (191)
VU-8223-650-5-P	2½"	12	8-9/16 (217)	4 (102)	14-23/32 (374)	7 (178)	5½ (140)						
	3"	13	9½ (241)	4¼ (108)	14-31/32 (380)	7½ (191)	6 (152)						
	4"	14	11½ (292)	4-15/16 (125)	15-21/32 (398)	9 (229)	7½ (191)						

a - Allow an additional 3" (76 mm) of height for cover removal on the NEMA 2 models and 5" (127 mm) on the NEMA 4 models.

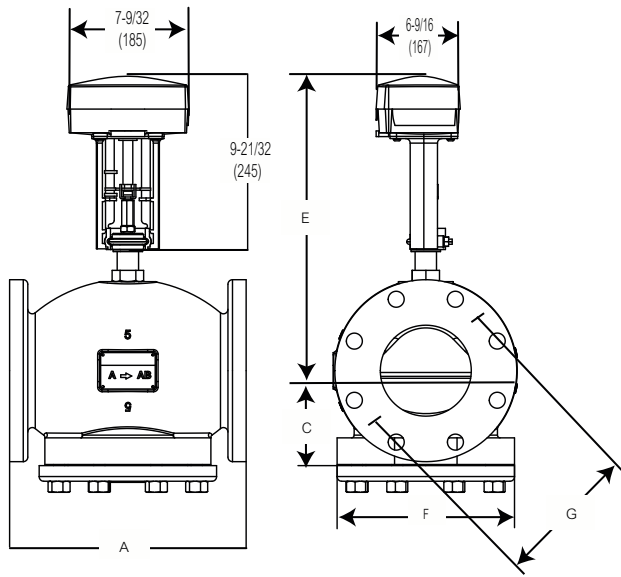

Figure 4 M900Ax Series U-Bolt Style with Flanged 2-Way Globe Valves

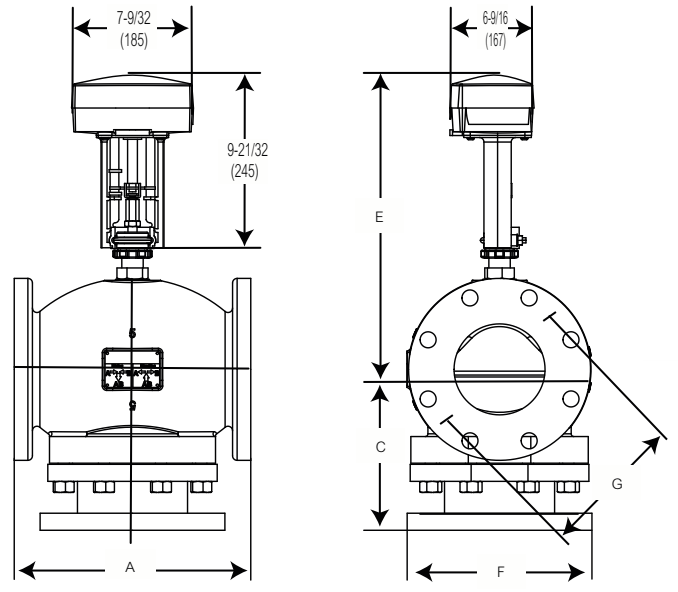

Figure 5 M900Ax Series U-Bolt Style with Flanged 3-Way Globe Valves

Valve Assemblies with Schneider Electric Forta M1500A Series, U-Bolt Mounting Style Series, Non-Spring Return 337 lbf Electric Linear Actuators

Actuator Specifications

Inputs	
Control Signal M1500A	Universal input signal, including floating, 0-10 Vdc, 2-10 Vdc, or 4-20 mA with 500 ohm resistor (included), reverse and direct acting, and proportional sequencing input signal ranges
Power Requirements	
Voltage	24 Vac ±10% @ 50/60 Hz, 20-30 Vdc
Power Input	24 VA running, 50 VA transformer sizing
Connections	Screw terminals; conduit knockouts
Motor Type	Brushless DC
Outputs	
Electrical	2...10 Vdc feedback
Auxiliary switch	Available on M1500A-S2. Rated 2A @ 24 Vac 2 SPDT Rated 4A @24 Vac
Mechanical	
Output force rating	337 lbf (1500 N) minimum
Timing	Floating 60 or 300 seconds, Proportional 15 seconds @ 1/2" stroke
Position indicator	Provided

Manual Override	Activated by the manual override crank
Linear stroke	Up to maximum of 3/8"...2" (9 mm to 52 mm) nominal, self adjusting
Environmental	
Temperature Limits	
Shipping and storage	-13...149 °F (-25...65 °C) ambient
Operating	Temperature at maximum valve fluid temperature, of 14...122 °F (-10 to 50 °C), 55 °F (13 °C) 14...113 °F (-10 to 45 °C), 281 °F (138 °C) 14...107 °F (-10 to 42 °C), 300 °F (149 °C) 14...100 °F (-10 to 38 °C), 340 °F (171 °C) 14...90 °F (-10 to 32 °C), 366 °F (171 °C)
Humidity	5 to 95% RH, non-condensing
Enclosure Rating	NEMA 2 with both conduit connectors used and vertically mounted
Agency Listings (Actuator)	
cULus	UL 873, Underwriters Laboratories (File # E9429 Category Temperature-Indicating and Regulating Equipment)
European Community	EMC Directive (89/336/EEC)

Dimensions - 2½"...6" Flanged Globe Valve Assemblies

Valve Assembly Part Number	Valve Size	P Code	Valve Dimensions in inches (mm)											
			2-Way					3-Way						
			A	C	E ^a	F	G	A	C	E ^a	F	G		
VU-8213-686-5-P	2½"	12	8-9/16 (217)	4 (102)	12-29/32 (328)	7 (178)	5½ (140)							
	3"	13	9½ (241)	4-5/8 (117)	12-5/8 (320)	7½ (191)	6 (152)							
	4"	14	11½ (292)	5-1/12 (140)	13-3/8 (339)	9 (229)	7½ (191)							
	5"	15	13 (330)	6-15/16 (176)	14-15/16 (379)	10 (254)	8½ (216)							
	6"	16	14 (356)	7½ (191)	18-23/32 (475)	11 (279)	9½ (241)							
VU-8303-686-5-P	2½"	12							8-9/16 (217)	5-7/16 (138)	12-19/32 (320)	7 (178)	5½ (140)	
	3"	13							9½ (241)	6-3/8 (162)	12-25/32 (325)	7½ (191)	6 (152)	
	4"	14							11½ (292)	8-7/16 (214)	13-27/32 (352)	9 (229)	7½ (191)	
	5"	15							13 (330)	8 13/16 (224)	15-5/32 (385)	10 (254)	8½ (216)	
	6"	16							14 (356)	7½ (191)	18-17/32 (471)	11 (279)	9½ (241)	
VU-8223-686-5-P	2½"	12	8-9/16 (217)	4 (102)	13-7/32 (336)	7 (178)	5½ (140)							
	3"	13	9½ (241)	4¼ (108)	13-9/32 (345)	7½ (191)	6 (152)							
	4"	14	11½ (292)	4-15/16 (125)	14-27/32 (377)	9 (229)	7½ (191)							
	5"	15	13 (330)	5-7/16 (138)	16-7/32 (412)	10 (254)	8½ (216)							
	6"	16	14 (356)	7½ (191)	19-29/32 (506)	11 (279)	9½ (241)							

a - Allow an additional 3" (76 mm) of height for cover removal.

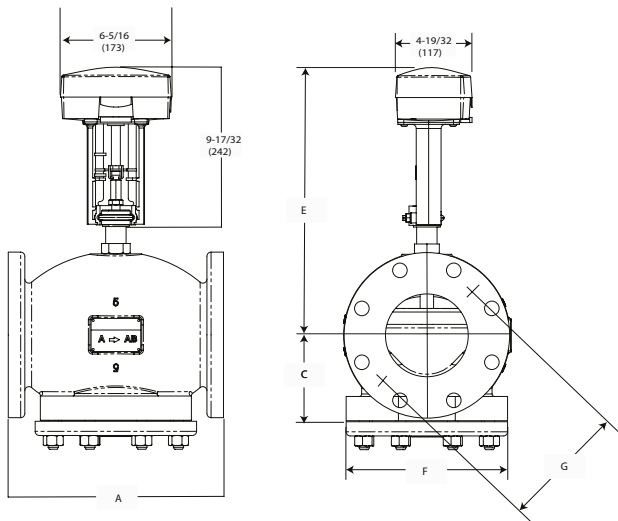

Figure 6 M1500A Series U-Bolt-style with Flanged 2-Way Globe Valves

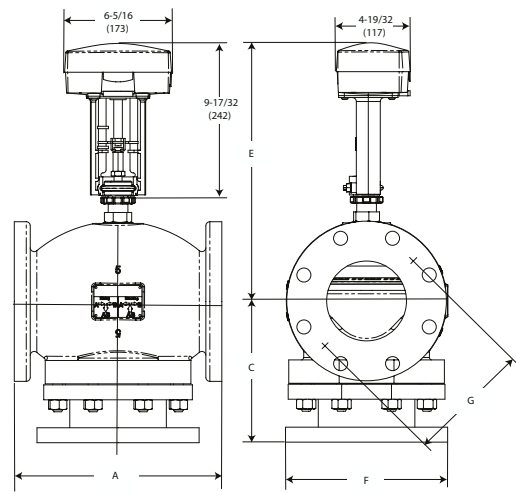

Figure 7 M1500A Series U-Bolt-style Flanged 3-Way Globe Valves

Valve Assemblies with Mx61-720x Spring Return Linear Electric SmartX Actuators

Actuator Specifications

Inputs	
Control Signal	SPST Two-position Control, Triacs (500 mA rated)
MA61-720x	SPDT Floating Point Control, 24 Vac
MF61-7203	Triacs (500 mA rated), or 2 SPST contacts
MS61-7203	Proportional, 2...10 Vdc or 4...20 mAdc with an external 500 ohm resistor
Power Requirements (see table) All 24 Vac circuits are Class 2	
Connections 3 ft. (91 cm) long appliance cables; 1/2" conduit connectors. For metric conduit use AM-756 adapter.	
Motor Type	Brushless DC
Outputs	
Electrical	
Control mode switch	Provided for selection of direct acting or reverse acting control mode on MS61-7203 proportional models
Position feedback voltage	2...10 Vdc (max. 0.5 mA) position feedback signal (MS61-7203)
Mechanical	
Output force rating	220 lbf (979 N) minimum, 495 lbf (2202 N) maximum stall
Timing	Approximate timing is 190 seconds
Position indicator	Provided on actuator and linkage for position indication
Manual override	Activated by the manual override crank
Linear Stroke	1" (25 mm) nominal
Environmental	
Temperature Limits	
Shipping and storage	-40...160 °F (-40...71°C) ambient
Operating	0...140 °F (-18...60 °C) ambient temperature
Maximum allowable ambient	140 °F (60 °C) at maximum fluid temperature of 281 °F (138 °C).
Minimum allowable valve fluid temperature	20 °F (-7 °C)
Humidity	5 to 95% RH, non-condensing

Enclosure Rating	NEMA 2, UL Type 2, IEC IP54, with customer-supplied water tight conduit connectors.
Agency Listings (Actuator)	UL 873, Underwriters Laboratories (File #E9429 Category Temperature-Indicating and Regulating Equipment)
European Community	EMC Directive (89/336 EEC) Low Voltage Directive (72/23/EEC)
cULus	Canadian Standards C22.2 No. 24-93
Australia	This product meets requirements to bear the RSM Mark according to the terms specified by the Communications Authority under the Radiocommunications Act 1992

Actuator Code	Part Number	Voltage 50/60 Hz	Power Input @ 50/60 Hz						
			Running				DC Amps	Holding (Hz)	
			50 Hz		60 Hz			50	60
VA	W	VA	W	W	W				
595	MA61-7200	120 Vac ±10%	11.7	8.8	10.0	8.4	—	3.6	5.0
594	MA61-7201	230 Vac ±10%	15.5	9.5	10.6	8.5	—	4.6	3.3
596	MA61-7203	24 Vac ±20% 22...30 Vdc	9.8	7.5	9.7	7.5	0.29	2.8	2.8
596	MF61-7203		9.8	7.7	9.7	7.7	0.30	3.3	3.3
596	MS61-7203		9.8	7.4	9.7	7.4	0.28	2.9	2.9
590	MS61-7203-40								
597	MS61-7203-50								

Dimensions - 2½"...5" Flanged Globe Valve Assemblies

Valve Assembly Part Number	Valve Size	P Code	Valve Dimensions in inches (mm)									
			2-Way (Refer to Figure 8)					3-Way (Refer to Figure 9)				
			A	C	E	F	G	A	C	E	F	G
2-Way Vx-8213-59x-5-P 3-Way Vx-8303-59x-5-P	2½"	12	8-9/16 (217)	4 (102)	12-3/8 (314)	7 (178)	5½ (140)	8-9/16 (217)	5-7/16 (138)	13-3/4 (349)	7 (178)	5½ (140)
	3"	13	9½ (241)	4-5/8 (117)	12-5/8 (320)	7½ (191)	6 (152)	9½ (241)	6-3/8 (162)	14 (356)	7½ (191)	6 (152)
	4"	14	11½ (292)	5-1/12 (140)	13-3/8 (340)	9 (229)	7½ (191)	11½ (292)	8-7/16 (214)	14-3/4 (375)	9 (229)	7½ (191)
	5"	15	13 (330)	6-15/16 (176)	15-1/8 (384)	10 (254)	8½ (216)	13 (330)	8-13/16 (224)	15-1/8 (384)	10 (254)	8½ (216)
2-Way Vx-8223-59x-5-P	2½"	12	8-9/16 (217)	4 (102)	13 (330)	7 (178)	5½ (140)	—				
	3"	13	9½ (241)	4¼ (108)	14½ (368)	7½ (191)	6 (152)					
	4"	14	11½ (292)	4-15/16 (125)	15-3/8 (391)	9 (229)	7½ (191)					
	5"	15	13 (330)	5-7/16 (138)	16-5/16 (415)	10 (254)	8½ (216)					

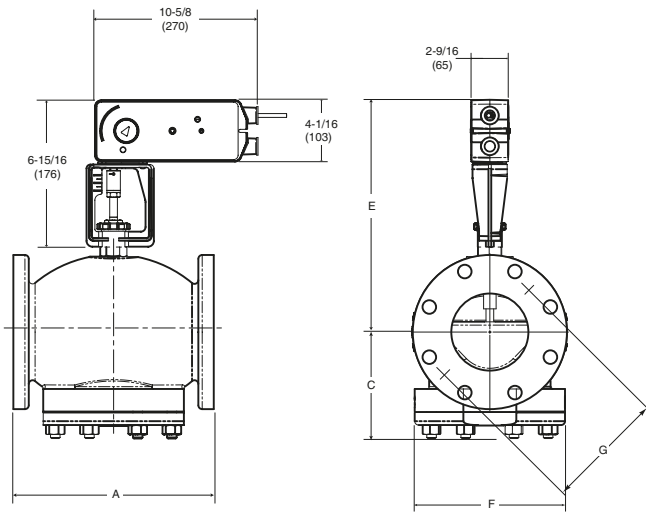

Figure 8 Mx61-720x with 2½"…5"
Flanged 2-Way Globe Valves

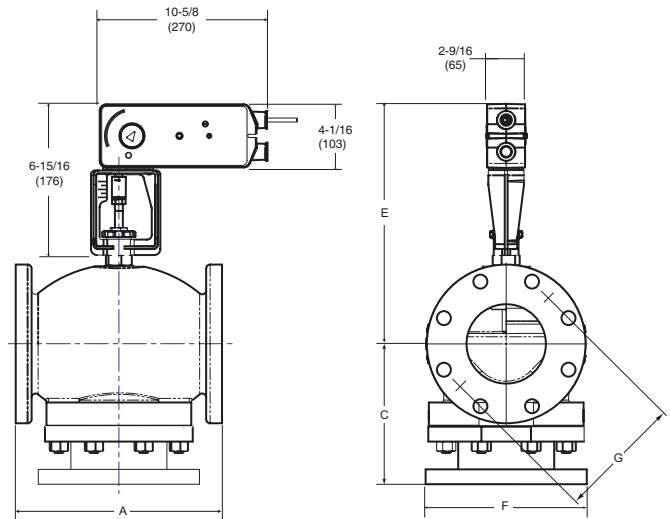

Figure 9 Mx41-720x with 2½"…5"
Flanged 3-Way Globe Valves

Valve Assemblies with Mx41-715x Spring Return Electric SmartX Actuators

Actuator Specifications

Inputs	
Control Signal	
MA41-715x	SPST Two-position Control, Triacs (500 mA rated)
MF41-7153	SPDT Floating Point Control, 24 Vac, Triacs (500 mA rated), or 2 SPST contacts
MS41-7153	Proportional, 2...10 Vdc or 4...20 mAdc with an external 500Ω resistor
Power Requirements (see table)	All 24 Vac circuits are Class 2.
Connections	3 ft. (91 cm) long appliance cables; 1/2" conduit connectors For metric conduit use AM-756 adapter
Motor Type	Brushless DC
Outputs	
Electrical	
Control mode switch	Provided for selection of direct acting or reverse acting control mode on MS41-7153 proportional models
Auxiliary switches	Two auxiliary switches available with Mx41-715x-502, SPDT 7A resistive @ 250 Vac, one fixed @ 5° and one adjustable 25° to 85°. Switches meet VDE requirements for 7A (2.5A) @ 250 Vac
Position feedback voltage	2...10 Vdc (maximum 0.5 mA) output signal for position feedback or operation of up to four slave actuators (MS41-7153 only)
Mechanical	
Output torque rating	133 lb-in (15 N-m) minimum
Timing	Approximate timing is 190 seconds
Position indicator	Pointer and scale are provided for position indication
Manual override	Activated by the manual override crank
Stroke	Electronically limited to a maximum of 95°; with mechanical stop

Environmental	
Temperature Limits	
Shipping and storage	-40...160°F (-40...71°C) ambient
Operating	-22 to 140°F (-30 to 60°C) ambient temperature. Maximum allowable ambient: 115°F (46°C) at maximum valve fluid temperature of 281°F (138°C). Minimum allowable valve fluid temperature: 20°F (-7°C)
Humidity	5 to 95% RH, non-condensing
Enclosure Rating	NEMA Type 2, UL Type 2, IEC IP54
Agency Listings (Actuator)	
UL	UL 873, Underwriters Laboratories (File #E9429 Category Temperature-Indicating and Regulating Equipment)
European Community	EMC Directive (89/336 EEC) Low Voltage Directive (72/23/EEC)
cULus	Canadian Standards C22.2 No. 24 Australia This product meets requirements to bear the RSM Mark according to the terms specified by the Communications Authority under the Radiocommunications Act 1992.

Actuator Code	Part Number	Power Input @ 50/60 Hz						
		Voltage 50/60 Hz	Running				Holding (Hz)	
			50 Hz VA	50 Hz W	60 Hz VA	60 Hz W	50 W	60 W
552	MA41-7150	120 Vac ±10%	11.7	8.8	10.0	8.4	3.6	5.0
554	MA41-7151	230 Vac ±10%	15.5	9.5	10.6	8.5	4.6	3.3
556	MA41-7153	24 Vac ±20%	9.8	7.5	9.7	7.5	2.8	2.8
556	MF41-7153	22-30 Vdc	9.8	7.7	9.7	7.7	3.3	3.3
556	MS41-7153	Vdc	9.8	7.4	9.7	7.4	2.9	2.9

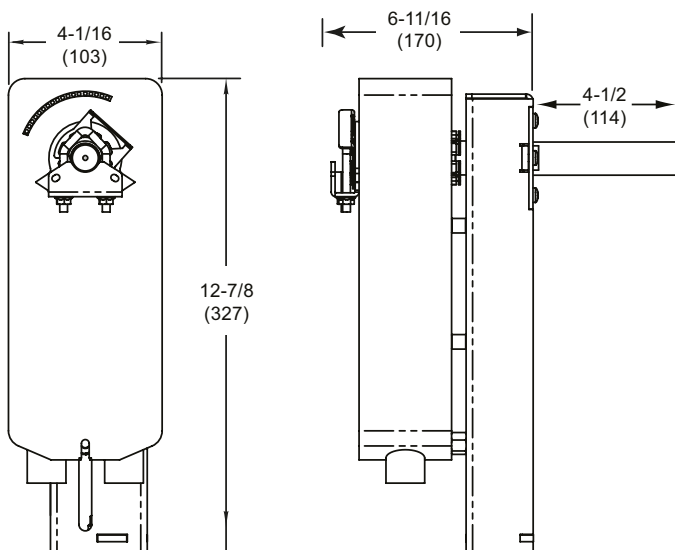

Figure 10 Mx41-715x-220 Actuator/Linkage Assembly

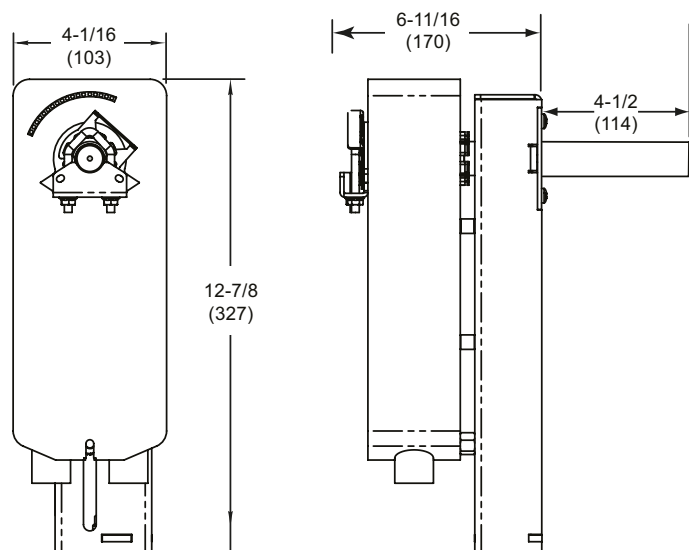

Figure 11 Mx41-715x-230 Actuator/Linkage Assembly

Dimensions - 2½”...6” Flanged Globe Valve Assemblies

Valve Assembly Part Number	Valve Size	P Code	Valve Dimensions in inches (mm)											
			2-Way (Refer to Figure 12)						3-Way (Refer to Figure 13)					
			A	C	E	F	G	H	A	C	E	F	G	H
2-Way Vx-8213-55x-5-P 3-Way Vx-8303-55x-5-P	2½”	12	8-9/16 (217)	4 (102)	17-5/8 (448)	7 (178)	5½ (140)	8-3/8 (213)	8-9/16 (217)	5-7/16 (138)	17-5/8 (448)	7 (178)	5½ (140)	8-3/8 (213)
	3”	13	9½ (241)	4-5/8 (117)	17½ (444)	7½ (191)	6 (152)	8-3/4 (222)	9½ (241)	6-3/8 (162)	17½ (444)	7½ (191)	6 (152)	8-3/4 (222)
	4”	14	11½ (292)	5½ (140)	18-5/8 (473)	9 (229)	7½ (191)	9-3/8 (238)	11½ (292)	8-7/16 (214)	18-5/8 (473)	9 (229)	7½ (191)	9-3/8 (238)
	5”	15	13 (330)	6-15/16 (176)	18-9/16 (472)	10 (254)	8½ (216)	10-1/16 (256)	13 (330)	8-13/16 (224)	18-5/8 (473)	10 (254)	8½ (216)	10-1/16 (256)
	6”	16	14 (356)	7½ (190)	19-15/16 (507)	11 (280)	9½ (241)	12 (305)	14 (356)	9-3/4 (248)	20-9/16 (522)	11 (280)	9½ (241)	12 (305)
2-Way Vx-8223-55x-5-P	2½”	12	8-9/16 (217)	4 (102)	16½ (419)	7 (178)	5½ (140)	8-3/8 (213)	—					
	3”	13	9½ (241)	4¼ (108)	17-5/8 (448)	7½ (191)	6 (152)	8-3/4 (222)	—					
	4”	14	11½ (292)	4-15/16 (125)	18½ (470)	9 (229)	7½ (191)	9-3/8 (238)	—					
	5”	15	13 (330)	5-7/16 (138)	19-3/4 (502)	10 (254)	8½ (216)	10-1/16 (256)	—					
	6”	16	14 (356)	6¼ (159)	21-3/8 (543)	11 (280)	9½ (241)	12 (305)	—					

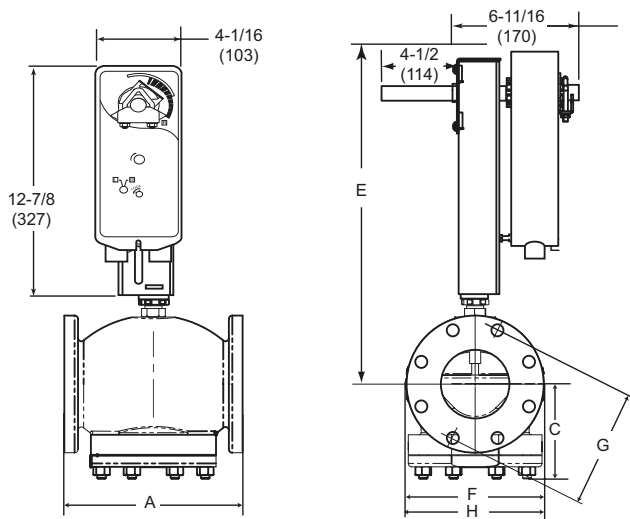

Figure 12 Mx41-715x with Flanged 2-Way Globe Valves

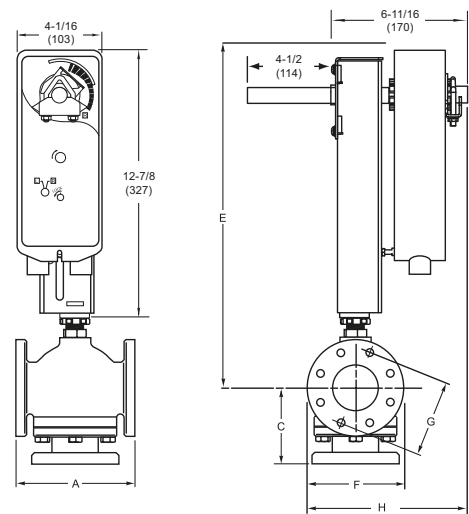

Figure 13 Mx41-715x with Flanged 3-Way Globe Valves

Valve Assemblies with Mx40-717x Spring Return Electric SmartX Actuators

Actuator Specifications

Inputs	
Control Signal	SPST Two-position Control, Triacs (500 mA rated)
MA40-717x	SPDT Floating Point Control, 24 Vac or 22-30 Vdc, Triacs (500 mA rated), or 2 SPST contacts.
MF40-7173	Proportional, 2...10 Vdc or 4...20 mAdc with the addition of a 500 ohm resistor (not included)
MS40-7173	
Power Requirements (see table)	All 24 Vac and 22...30 Vdc circuits are Class 2

Connections	
Class 1 Power	2 ft. (61 cm) long appliance cables;
Class 2 Power & Control	36 inch (91 cm) long 22 AWG color coded appliance cable 1/2" conduit connectors. For metric conduit use AM-756 adapter

Motor Type	Brushless DC
------------	--------------

Outputs	
Mechanical	
Output torque rating	150 lb-in (17 N-m)
Timing	Approximate timing is 147 sec. for proportional models 162 sec. for floating and two-position models

Position indicator	Pointer and scale are provided for position indication
--------------------	--

Stroke	Proportional models electronically limited to a maximum of 92° ±1°. Floating & 2-position models mechanically limited to 101 ±1°
--------	--

Environmental	
Temperature Limits	
Shipping and storage	-40...160 °F (-40...71 °C) ambient
Operating	-25...140 °F(-32...60 °C) ambient
Maximum allowable ambient	133 °F (56 °C) at maximum valve fluid temperature of 281 °F (138 °C).
Minimum allowable valve fluid temperature	20°F (-7°C)
Humidity	5 to 95% RH, non-condensing

Enclosure Rating	NEMA Type 1, NEMA Type 4; UL Type 4 (IEC IP56), with customer supplied water tight conduit connectors
------------------	---

Agency Listings (Actuator)	UL
UL	UL 873, Underwriters Laboratories (File #E9429 Category Temperature-Indicating and Regulating Equipment)

European Community	EMC Directive (2004/108/EC) Low Voltage Directive (72/23/EEC)
--------------------	---

cULus	Canadian Standards C22.2 No. 24-93
Australia	This product meets requirements to bear the RSM Mark according to the terms specified by the Communications Authority under the Radiocommunications Act 1992.

Actuator Code	Part Number	Power Input @ 50/60 Hz			
		Voltage	Running VA	Holding VA	Watts
572	MA40-7170	120 Vac ±10%	8.4	6.6	6.2
574	MA40-7171	240 Vac ±10%	9.8	8.5	6.5
576	MA40-7173	24 Vac ±20%	7.4	5.1	5.3
		22-30 Vdc	5.0	3.0	5.0
576	MF40-7173	24 Vac ±20%	8.1	5.3	5.8
		22-30 Vdc	5.7	3.6	5.7
572	MS40-7170	120 Vac ±10%	8.5	5.2	6.4
574	MS40-7171	240 Vac ±10%	10.8	9.0	7.2
576	MS40-7173	24 Vac ±20%	7.8	4.7	5.5
		22-30 Vdc	5.6	2.5	5.0

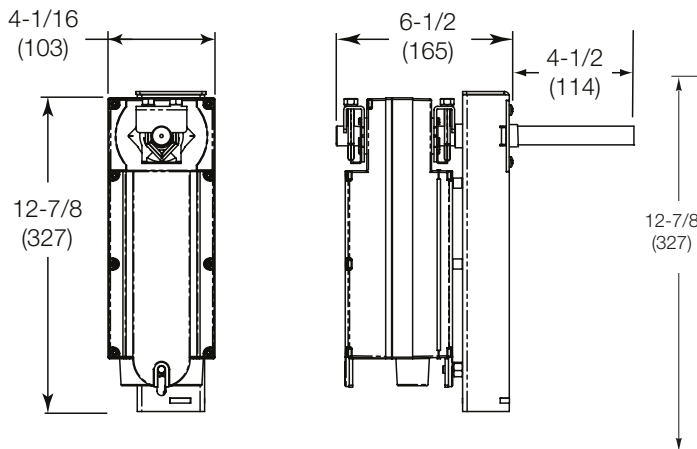

Figure 14 Mx40-717x-220 Actuator/Linkage Assembly

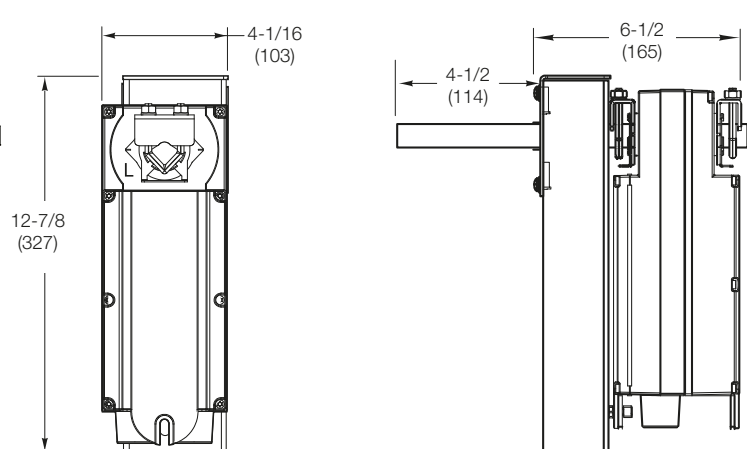

Figure 15 Mx40-717x-230 Actuator/Linkage Assembly

Dimensions - 2½" ...6" Flanged Globe Valve Assemblies

Valve Assembly Part Number	Valve Size	P Code	Valve Dimensions in inches (mm)											
			2-Way (Refer to Figure 16)						3-Way (Refer to Figure 17)					
			A	C	E	F	G	H	A	C	E	F	G	H
2-Way Vx-8213-57x-5-P 3-Way Vx-8303-57x-5-P	2½"	12	8-9/16 (217)	4 (102)	17¼ (438)	7 (178)	5½ (140)	8-3/4 (222)	8-9/16 (217)	5-7/16 (138)	17¼ (438)	7 (178)	5½ (140)	8-3/4 (222)
	3"	13	9½ (241)	4-5/8 (117)	17 (432)	7½ (191)	6 (152)	9 (229)	9½ (241)	6-3/8 (162)	17 (432)	7½ (191)	6 (152)	9 (229)
	4"	14	11½ (292)	5½ (140)	18¼ (464)	9 (229)	7½ (191)	9-3/4 (248)	11½ (292)	8-7/16 (214)	18¼ (464)	9 (229)	7½ (191)	9-3/4 (248)
	5"	15	13 (330)	6-15/16 (176)	18-3/16 (462)	10 (254)	8½ (216)	10-1/16 (256)	13 (330)	8-13/16 (224)	17¼ (464)	10 (254)	8½ (216)	10-1/16 (256)
	6"	16	14 (356)	7½ (190)	19-15/16 (507)	11 (280)	9½ (241)	12 (305)	14 (356)	9-3/4 (248)	20¼ (515)	11 (280)	9½ (241)	12 (305)
2-Way Vx-8223-57x-5-P	2½"	12	8-9/16 (217)	4 (102)	16-5/8 (422)	7 (178)	5½ (140)	8-3/4 (222)						
	3"	13	9½ (241)	4¼ (108)	17¼ (438)	7½ (191)	6 (152)	9 (229)						
	4"	14	11½ (292)	4-15/16 (125)	18¼ (464)	9 (229)	7½ (191)	9-3/4 (248)						
	5"	15	13 (330)	5-7/16 (138)	19-3/8 (492)	10 (254)	8½ (216)	10-1/16 (256)						
	6"	16	14 (356)	6¼ (159)	21-3/8 (543)	11 (280)	9½ (241)	12 (305)						

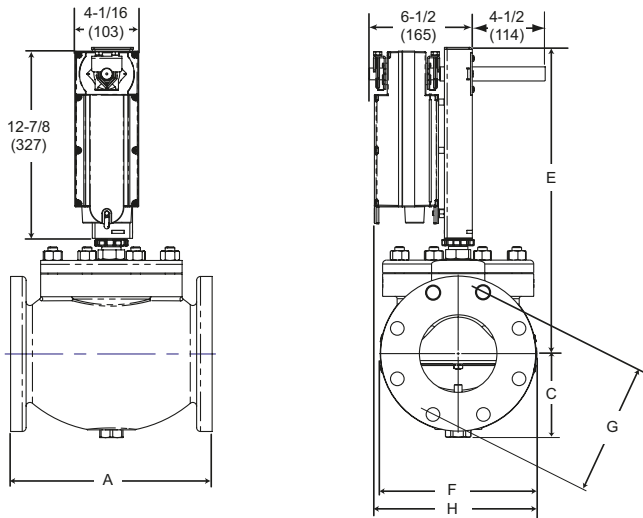

Figure 16 Mx40-717x with Flanged 2-Way Globe Valves

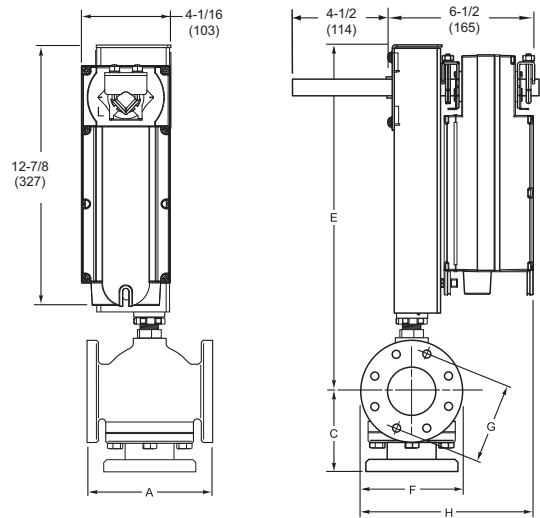

Figure 17 Mx40-717x with Flanged 3-Way Globe Valves

Valve Assemblies with MK-6811 and MK-6911 Spring Return Pneumatic Actuators

Actuator Specifications

Inputs	
Control Signal	5...10 psig (34 to 69 kPa)
Positive positioner start point adjustable	1 to 12 psi (7 to 83 kPa).
Positive positioner span adjustable	2 to 13 psi (14 to 89 kPa).
Supply Pressure	15 to 20 psig (103 to 137 kPa) nominal, 30 psig (205 kPa) maximum.
Air Connections	1/8 in FNPT
Effective Area	50 sq. in. (323 cm ²)
Outputs	
MK-6811	1" (25 mm) nominal stroke
MK-6911	1-3/4" (45 mm) nominal stroke
Environmental	
Temperature Limits	
Shipping and storage	-40...160 °F (-40...71 °C) ambient
Operating	-20...220°F (-29...104°C)
Maximum allowable ambient	220 °F (104°C) at maximum valve fluid temperature of 281°F (138°C)
Minimum allowable valve fluid temperature	20 °F (-7 °C)
Positive Positioner	½ AK-42309-500 recommended for 5" valve, required for 6" valve. Order separately Supplied as standard on VK4 factory valve assemblies

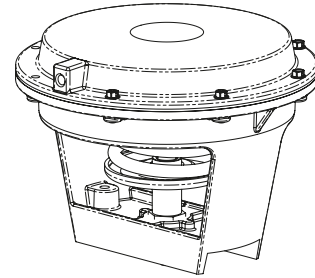

Figure 18 MK-6811 Actuator

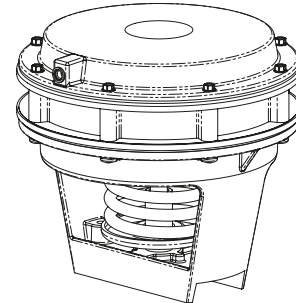

Figure 19 MK-6911 Actuator

Dimensions - 2½" to 6" Flanged Globe Valve Assemblies

Valve Assembly Part Number ^a	Valve Size	P Code	Valve Dimensions in inches (mm)									
			2-Way (Refer to Figure 20 and Figure 22)					3-Way (Refer to Figure 21 and Figure 23)				
			A	C	E	F	G	A	C	E	F	G
2-Way VK-8213-602-5-P VK4-8213-6x2-5-P 3-Way VK-8303-602-5-15 VK4-8303-6x2-5-P	2½"	12	8-9/16 (217)	4 (102)	15-7/8 (403)	7 (178)	5½ (140)	8-9/16 (217)	5-7/16 (138)	15-5/8 (397)	7 (178)	5½ (140)
	3"	13	9½ (241)	4-5/8 (117)	16-1/4 (413)	7½ (191)	6 (152)	9½ (241)	6-3/8 (162)	16-1/4 (413)	7½ (191)	6 (152)
	4"	14	11½ (292)	5½ (140)	16-7/8 (429)	9 (229)	7½ (191)	11½ (292)	8-7/16 (214)	16-7/8 (429)	9 (229)	7½ (191)
	5"	15	13 (330)	6-15/16 (176)	18-3/16 (462)	10 (254)	8½ (216)	13 (330)	8-13/16 (224)	18-3/16 (462)	10 (254)	8½ (216)
	6"	16	14 (356)	7½ (190)	18-3/16 (462)	11 (280)	9½ (241)	14 (356)	9-3/4 (248)	21-9/16 (548)	11 (280)	9½ (241)
2-Way VK-8223-602-5-P VK4-8223-6x2-5-P	2½"	12	8-9/16 (217)	4 (102)	18-3/16 (462)	7 (178)	5½ (140)	—	—	—	—	—
	3"	13	9½ (241)	4-1/4 (108)	16-5/8 (422)	7½ (191)	6 (152)	—	—	—	—	—
	4"	14	11½ (292)	4-15/16 (125)	17-7/8 (454)	9 (229)	7½ (191)	—	—	—	—	—
	5"	15	13 (330)	5-7/16 (138)	19-3/8 (492)	10 (254)	8½ (216)	—	—	—	—	—
	6"	16	14 (356)	6-1/4 (159)	22-15/16 (583)	11 (280)	9½ (241)	—	—	—	—	—

a - VK4 factory assemblies include AK-42309-500 positive positioner. Positive positioner optional for 2½" to 5", required for 6".

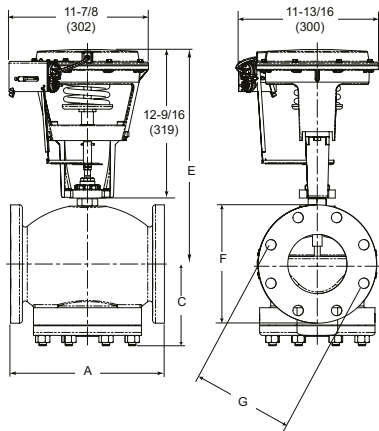

Figure 20 MK-6811 with Flanged 2-Way Globe Valves^a

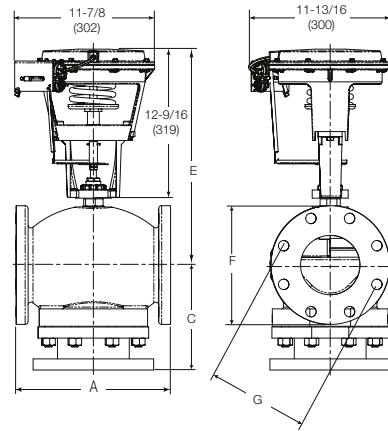

Figure 21 MK-6811 with Flanged 3-Way Globe Valves^a

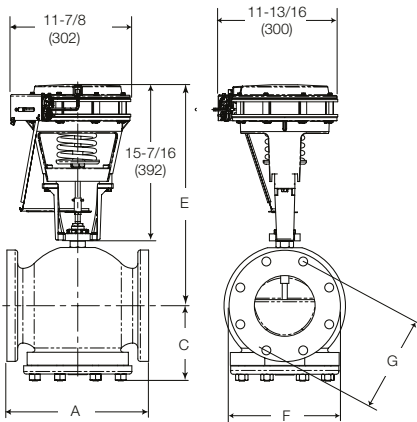

Figure 22 MK-6911 with Flanged 2-Way Globe Valves^a
a - Shown with positive positioner

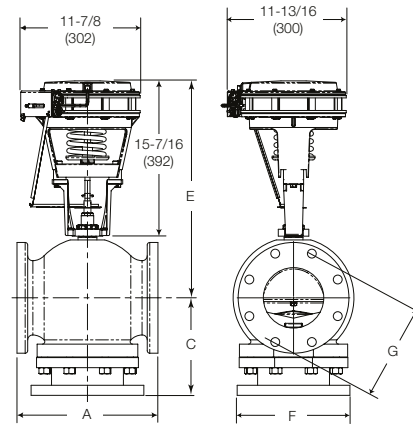

Figure 23 MK-6911 with Flanged 3-Way Globe Valves^a

System Design Considerations

Linked Globe Valve Assemblies

The information in this section describes characteristics of the VB-8xx3 valve bodies, which are used in the Vx-8xx3 valve assemblies. This information is also useful when installing the Mx4x-xxxx-2xx series actuator/linkage assemblies onto these valve bodies.

Control Precision: 2-Way Valves

The flow curve shown in Figure 24 is representative of all sizes. All valve plugs have lower gain when nearly closed to enhance control at low demand. Two-way valves are nominally equal percentage and normally used for water and low pressure steam.

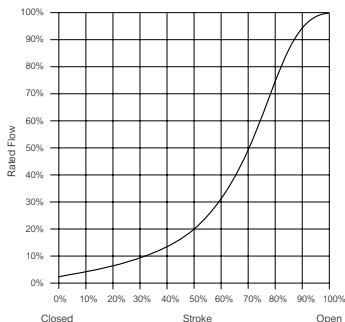

Figure-24 Typical Modified Equal Percentage Flow Characteristics

3-Way Valves

3-way mixing valves are designed so that the flow from either of the inlet ports to the outlet is nominally linear, which means the total flow from the outlet is almost constant over the stroke of the valve stem. The flow is limited at the initial opening similar to an equal percentage curve to enhance system stability. See Figure 25 for typical flow characteristics of the VB-8303 series valve bodies.

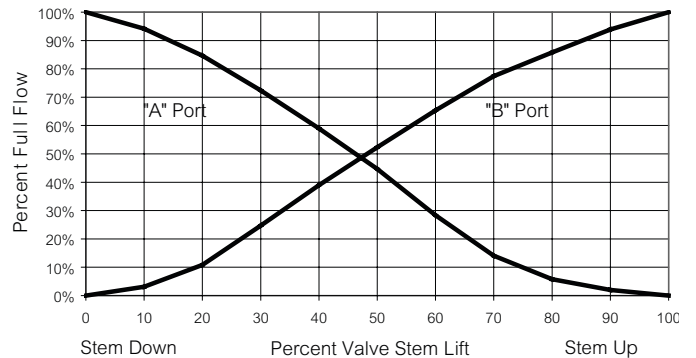

Figure-25 Typical Flow Characteristics

Rangeability

Rangeability is the ratio of rated flow to the minimum controllable flow through a valve. The nominal rangeability of the VB-8xx3 Series is greater than 100:1.

Temperature/Pressure Ratings

See Figure 26 for temperature and pressure ratings of 2-way and 3-way valves. Ratings conform with published values and disclaimer.

VB-8xx3-0-5-P (Cast Iron Body with Flanged End Fittings)

Standards: Pressure to ANSI B16.1, Class 125, with 200 psi (1379 kPa) up to 150 °F (65 °C), decreasing to 169 psi (1165 kPa) at 281 °F (138 °C).

Materials: Valve body: Cast iron, ASTM A126 Class B.

Trim: Stainless steel stem, forged brass plug, metal-to-metal or EPDM seat ring with TFE/EPDM packing parts and silicone packing grease.

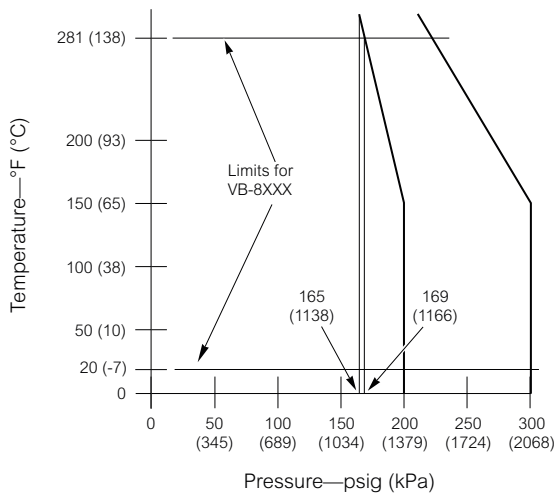

Figure-26 Temperature and Pressure Ratings for VB-8xx3 Series Globe Valves

Close-off Ratings

Nominal actuator close-off ratings are based on ANSI IV (0.01% leakage) for valves with EPDM seat rings such as VB-8213 and VB-8223. Metal-to-metal trim valves such as VB-8303 are designed for ANSI III (0.1% leakage).

Installation Considerations

Mounting Angle of Valve Assembly

Be sure to allow the necessary clearance around the valve assembly. The valve assembly must be mounted so that the valve stem is at least 5° above the horizontal. This ensures that any condensate that forms on the valve body will not travel into the linkage or actuator, where it may cause corrosion. On steam applications, where the ambient temperature approaches the limit of the actuator, the valve assembly must be mounted 45° from vertical.

Insulation of Linked Globe Valve Assembly

The globe valve should be completely insulated to minimize the effect of heat transfer and condensation at the actuator.

Caution: The actuator/linkage must not be insulated. Doing so will result in excess heat or condensation within the actuator.

Temperature Limits for Globe Valve Assembly

When installing the globe valve assembly, observe the minimum and maximum temperature limits given in the Actuator Specifications and Valve Assembly Mounting Dimensions section of this document.

Sizing and Selection

Flow Coefficient (C_v)

Sizing a valve requires selecting a flow coefficient (C_v), which is defined as the flow rate in gallons per minute (GPM) of 60 °F water that will pass through the fully open valve with a 1 psi pressure drop (D_p). It is calculated according to the formula:

$$C_v = \frac{GPM}{\sqrt{\Delta P}}$$

Since the flow rate and resultant pressure drop through the heat exchanger is usually specified, the only variable normally available in sizing a valve is the valve pressure drop. The following information can be used to determine what pressure drop to use in calculating a valve C_v. Using the calculated C_v, refer to Step 6 to select the valve body with the nearest available C_v.

Be sure to check that the anticipated pressure drop across the valve will not exceed the close-off pressure ratings in Table 1 and the maximum pressure differential ratings listed in Table 8 to Table 13.

Two-position Control

Two-position control valves are normally selected “line size”... keep pressure drop at a minimum. If it is desirable to reduce the valve below line size, then 10% of “available pressure” (that is, the pump pressure differential available between supply and return mains with design flow at the valve location) is normally used to select the valve.

Proportional Control

Proportional control valves are usually selected to take a pressure drop equal to at least 50% of the “available pressure.” As “available pressure” is often difficult to calculate, the normal procedure is to select the valve using a pressure drop at least equal to the drop in the coil or other load being controlled (except where small booster pumps are used) with a minimum recommended pressure drop of 5 psi (34 kPa). When the design temperature drop is less than 60 °F (33 °C) for conventional heating systems, higher pressure drops across the valve are needed for good results (Table 15).

Table 15 Conventional Heating System

Design Temperature Load Drop °F (°C)	Recommended Pressure Drop ^a (% of Available Pressure)	Multiplier on Load Drop
60 (33) or More	50%	1 x Load Drop
40 (22)	66%	2 x Load Drop
20 (11)	75%	3 x Load Drop

a - Recommended minimum pressure drop = 5 psi (34 kPa).

Secondary Circuits with Small Booster Pumps

50% of available pressure difference (equal to the drop through load, or 50% of booster pump head).

3-Way Mixing Valves Used to Bypass Flow

When 3-way linked globe valve assemblies are used to control flow through a heating or cooling coil, the valve assembly is piped as a mixing valve on the outlet side of the coil to throttle the water flow through the load, and therefore control the heat output of the coil (Figure 27).

3-Way Mixing Valves Used to Blend Water Flows

Three-way mixing valves used to blend two water flows (Figure 28) control the heat output by varying the water temperature

to the load at constant flow. These valves do not require high pressure drops for good control results. They can be sized for a pressure drop of 20% of the “available pressure” or equal to 25% of the pressure drop through the load at full flow.

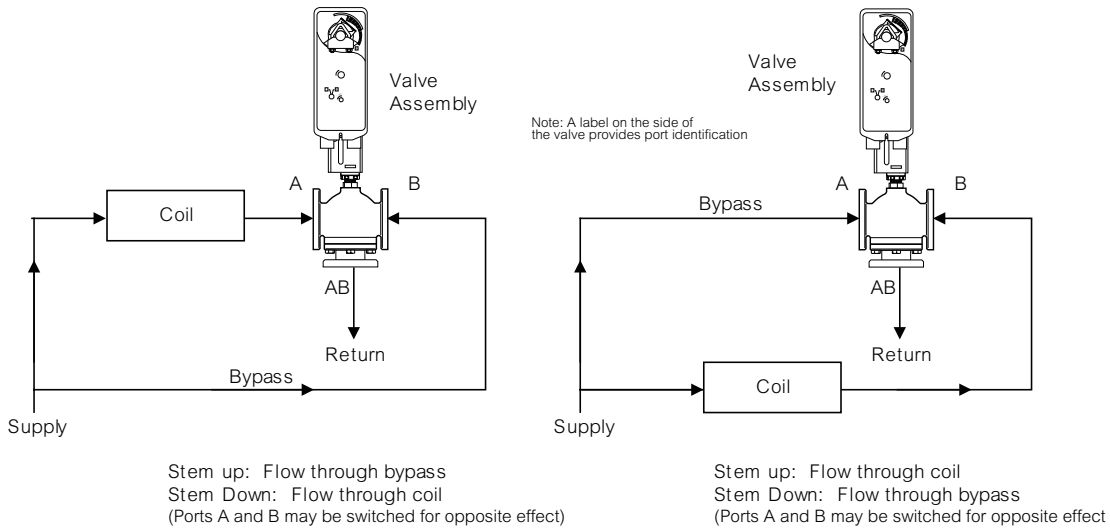

Figure-27 Typical Piping Choices for VB-8303 as 3-Way Mixing Valve for Control of Heating or Cooling Coil

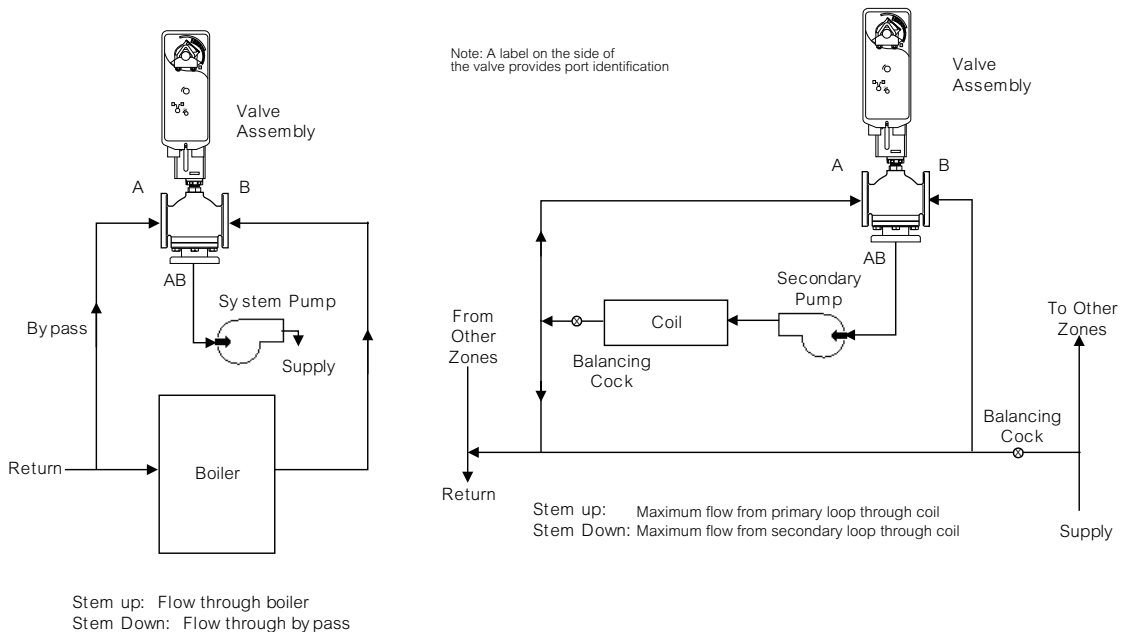

Figure-28 Typical Piping Choices for VB-8303 as 3-Way Mixing Valve for Proportional Control Used to Blend Two Water Flows.

3-Way Diverting Valves

Proportional and two-position 3-way diverting linked globe valve assemblies are used to control the flow of hot or chilled fluids in heating systems, cooling coils, or other load by diverting the flow to either the load or a bypass. The valve must be piped with one inlet and two outlets. (Figure 29).

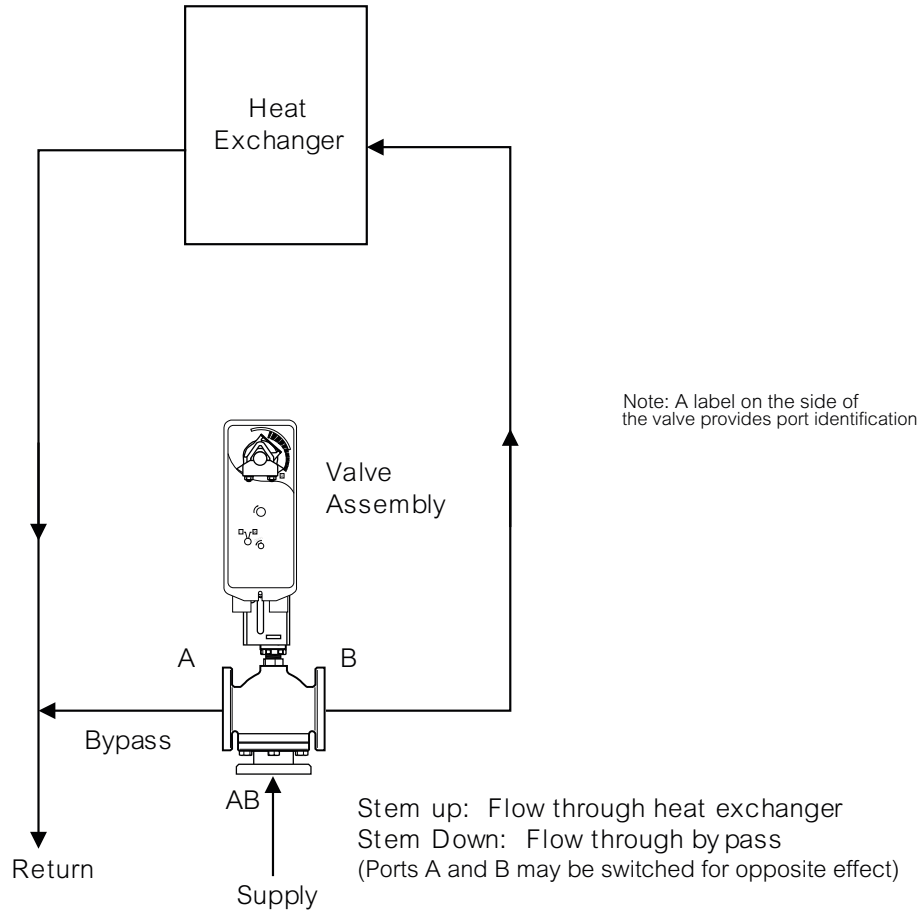

Figure-29 Typical Piping of VB-8303 as 3-Way Diverting Valve