



SmartX Actuators MG350V

The platform of the future for a wide range
of globe valve applications



MG350V Applications

HVAC can account for 40% of energy costs in a building. Efficient, smart buildings start at their foundation with reliable control devices like the SmartX MG350V. The MG350V delivers critical data on system conditions to the higher level BMS in a wide range of globe valve applications.

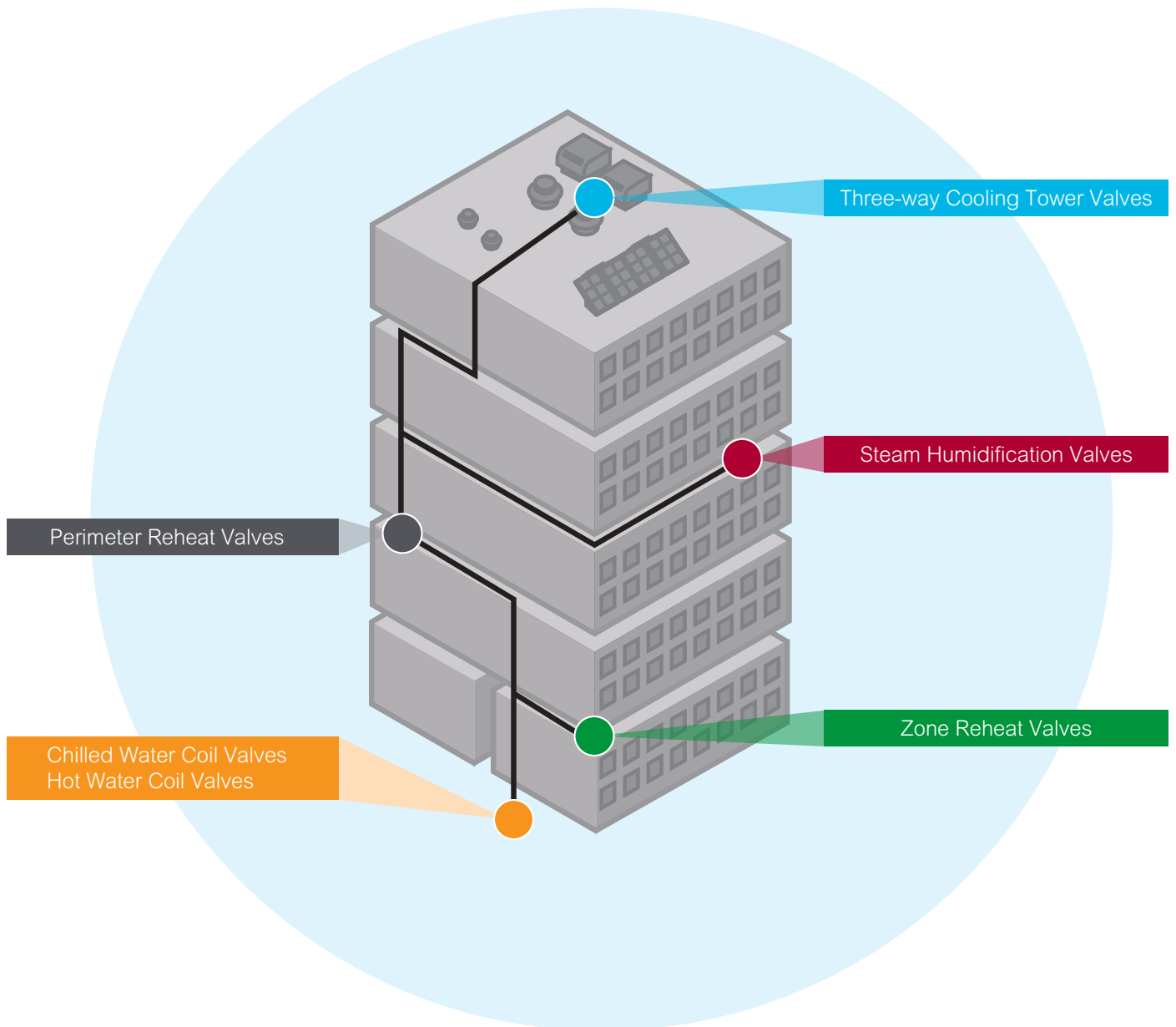

Smart starts at the foundation of the BMS with devices like the SmartX Actuator MG350V. If the device level is not performing - neither is the BMS.

MG350V Overview

The MG350 is the platform of the future that represents the evolution of Schneider Electric's decades of experience in the design and manufacture of valve actuators and other HVAC products. Smart devices like the MG350V provide precise building control and deliver critical information to the BMS about changes in the physical environment and the state of the valve/actuator operation.

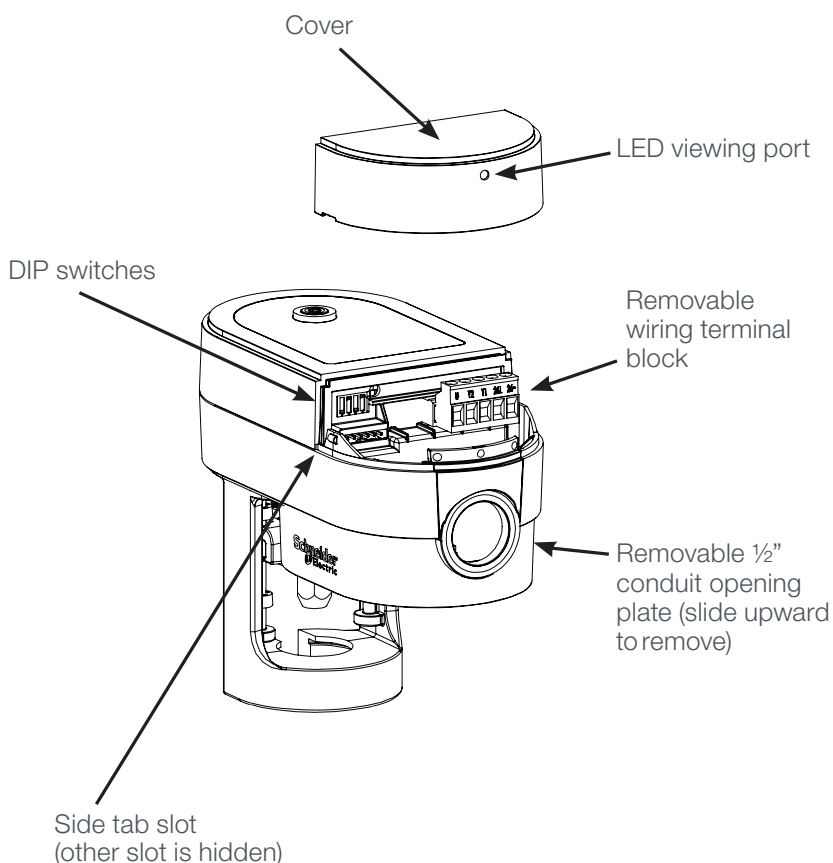

Features and Benefits

- > Provides direct mounting on 1/2" to 2" VB-7000 globe valves with no additional linkage required
- > Compatible with 1/2" to 1-1/4 " obsolete VB-9000 globe valves
- > Bi-color LED status delivers visual indication of valve motion and alarm notification
- > Auto calibration provides precise control by scaling the input signal to match the exact travel of the valve stem
- > Stall protection throughout the stroke means uninterrupted, smooth control
- > Field selectable feedback signal is compatible with a wide range of controllers
- > Manual override with automatic release ensures fail safe operation
- > Range offers users a choice with: floating, two position, proportional and pulse width modulating (PWM) model options
- > Integral linkage delivers design simplicity
- > Five year warranty

Schneider Electric Globe Valve and Actuators - Product Overview and Specifications

MG350V globe valve actuators are non-spring return electromechanical SmartX Actuators.

Schneider Electric Globe Valve Actuator Ranges

Range Name	Description	Family	Electric Non Spring Return Operation				Electric Spring Return Operation			Pneumatic Spring Return Operation	
			Proportional	Floating	Pulse Width Modulated	Two Position	Proportional	Floating	Two Position	Proportional/ Two Position	Proportional with Positive positioner
SmartX	Originally developed by Schneider Electric in the United States under the DuraDrive brand. Upgraded in 2015 to SmartX with new features.	Mx51-710x					●	●	●		
		Mx51-720x, Mx61-720x ¹					●	●	●		
		MG350V	● New	● New	● New	● New					
Forta	Developed by Schneider Electric in Europe. Introduced to North America in 2008 because of its flexibility and ease of setup. ²	M400, M800, M1500		●			● 3-Wire				
		M900					● New	● New, 3-Wire			
Legacy	Earlier North American actuators developed by Schneider Electric (Barber Colman, Siebe, Invensys). Still popular because of their value and reliability.	MK-2690, MK-4xxx, MK-6xxx, MK-8xxx								●	●
		MA-521x, MP-521x, MP-541x, MP-5513, MPR-5613					●		●		

¹ The Mx51-720x, Mx61-720x actuator are higher force versions of the Mx51-710x for large valves and high close-off applications.

² Forta actuators have universal inputs for proportional and floating operation. The new M900 Forta actuator will have both spring return up and down and NEMA 4 options.

Valve Body Families*

Valve Size	VB-7000 (two way NC, two way NO, three way mixing, three way diverting)	VB-8000 (two way NC, two way NO, three way diverting/mixing)	VB-9313 (three way mixing)
1/2"	●		
3/4"	●		
1"	●		
1-1/4"	●		
1-1/2"	●		
2"	●		
2-1/2"		●	●
3"		●	●
4"		●	●
5"		●	●
6"		●	●

*For more detailed specification information access the NAM Globe Valves and Actuators Catalog on the [Exchange](https://ecobuilding.schneider-electric.com/Exchange). <https://ecobuilding.schneider-electric.com/>

Schneider Electric

839 N. Perryville Road
Rockford, IL 61107
Tel. +1 888-444-1311
www.schneider-electric.com

New MG350V Actuator Family Overview

Part Number	Input Signal	Position Feedback Output Signal	Approx Timing in seconds for 1/2" (12.7 mm) Stroke	Max. Stroke in inch (mm)	Force lbf (N)	Availability
MG350V-24F	Three-Wire Floating ¹	-	102	21/32 16.5	78 (350)	Q3 2016
MGF350V-24FP	Three-Wire Floating, PWM 1,2	2 to 10 Vdc, 0 to 5 Vdc ³	64	21/32 16.5	67 (300)	Q4 2016
MG350V-24M	2 to 10 Vdc, 0 to 10 Vdc	-	102	21/32 16.5	78 (350)	Q3 2016
MGF350V-24MP	2 to 10 Vdc, 0 to 10 Vdc, 4 to 20 mA	2 to 10 Vdc, 0 to 5 Vdc ³	64	21/32 16.5	67 (300)	Q4 2016

¹ Also compatible with two-position Form A 24 Vac/Vdc input signals.

² Field-selectable 0.59 to 2.93 sec and 0.1 to 25.5 sec PWM ranges.

³ Field selectable. The 2 to 10 Vdc output signal range also includes an alarm signal.

Product Support Services email: productsupport@schneider-electric.com

Exchange: <https://ecobuilding.schneider-electric.com>

For more information contact:

NAM Business Development

Lonnie Laue Phone: (972) 323-5526 lonnie.laue@schneider-electric.com

Offer Management

Mark Sarna Phone: (815) 381-5061 mark.sarna@schneider-electric.com