

POWERS™ CONTROLS

LC Pneumatic Damper Actuator

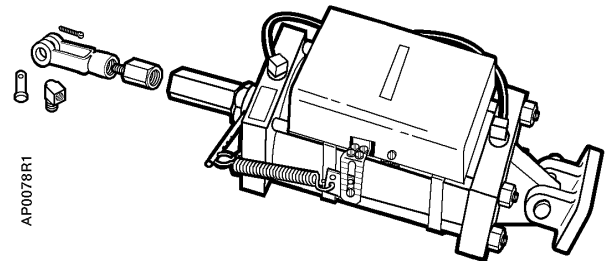

Description

The LC Actuator is a piston type pneumatic actuator. Air pressure is supplied to both sides of the piston to provide a force balance movement of the shaft. The thermostat signal is amplified by the action of positioning and reversing relays. These relays give the necessary volume of air to position the actuator quickly. The LC Actuator is designed to develop very high thrust with capacity to handle heavy loads.

Features

- Pivot mounting
- Adjustable span and start point
- Large effective piston area
- Long stroke

Product Number

331-2882

Specifications

| | |
|---|---|
| Effective Piston Area | 19.6 inches ² (126 cm ²) |
| Stroke | 7 inches (18 cm) |
| Maximum Air Pressure | 30 psi (210 kPa) |
| Nominal Operating Range (Factory Setting) | 3 to 13 psi (21 to 90 kPa) |
| Ambient Temperature Range | |
| Operating | 50 to 140°F (10 to 60°C) |
| Storage | -20 to 160°F (-29 to 71°C) |
| Response | 0.5 psig (3.5 kPa) |
| Air Connection | 1/8-inch NPT |
| Type of Mounting | Pivot |
| Thrust Force/Torque Rating | See Table 1 |
| Air Usage | 75 SCIM (1230 cm ³) |
| Shipping Weight | 35 lb (16 kg) |
| Dimensions | See Figure 10 |

Application

The LC Actuator is recommended to operate devices having high torque loads. Some examples are:

Large Dampers

Mixed air thermostat positions the LC Actuator to control the damper. The E.P. valve and check release returns the damper to its normally closed position when the fan is stopped. An auxiliary tank, 1000 inches³ capacity (16,400 cm³), will ensure damper closure in case of air failure.

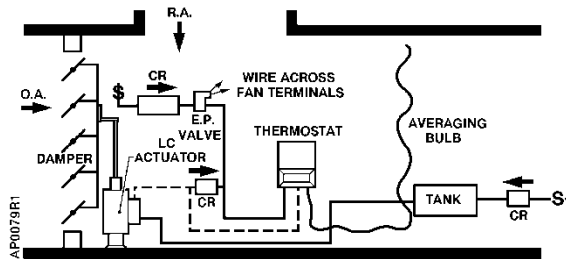

Figure 1. Large Dampers.

Fan Inlet Vanes

A static pressure transmitter in the fan discharge positions the inlet vane damper, through a receiver-controller, to maintain the desired static pressure.

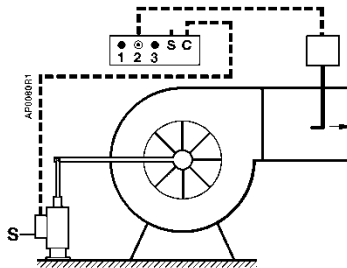

Figure 2. Fan Inlet Vanes (NC).

Centrifugal Compressor Inlet Vanes

Thermostat with bulb in chilled discharge water positions the LC Actuator to vary position of the compressor inlet vanes according to demand. The P.E. switch will cut out the compressor when the vanes are closed.

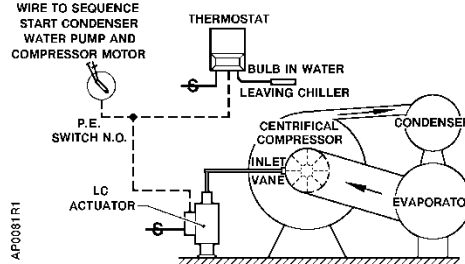

Figure 3. Centrifugal Compressor Control.

**Application,
 Continued**

**Hydraulic Speed
 Control**

A positioning switch operates the LC Actuator to position the hydraulic speed control lever to vary the blower speed. If the actuator responds too quickly to control system changes, add a restrictor to each of the two control lines attached to the actuator cylinder. The smaller the restrictor, the slower the actuator response time.

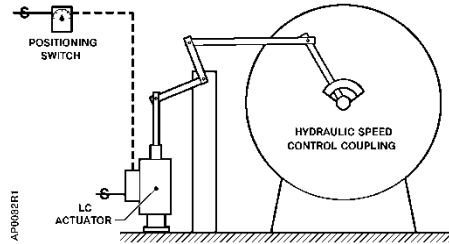

Figure 4. Hydraulic Speed Control.

| | | |
|--------------------|--|---------|
| Accessories | Crank Kit (crank for 1/2-inch (13 mm) diameter shaft includes 2 set screws) | 331-535 |
| | O-ring Kit | 333-056 |
| | Spring Clamp (secures 1/4-inch O.D. poly tubing to barb-fitting at higher control pressures) | 531-833 |

Sizing

For applications such as inlet vanes and hydraulic speed controls, get the total torque requirement at maximum load conditions from the damper manufacturer.

For large damper applications, determine the total torque requirements as follows:

1. Obtain damper torque ratings (lb-in/ft²) from the damper manufacturer.
2. Determine the area of the damper.
3. Calculate the total torque required to move the damper:

$$\text{Total Torque} = \text{Torque Rating} \times \text{Damper Area}$$

4. Select the total quantity of actuators required:

$$\text{Number of Actuators} = \frac{\text{Total Torque Required}}{\text{SF}^1 \times \text{Actuator Torque (See Table 1)}}$$

¹Safety Factor: When calculating the number of actuators required, a safety factor should be included for unaccountable variables such as slight misalignments, aging of the damper, etc. A suggested safety factor is 0.80 (or 80% of the rated torque).

See *AB-300 Damper Actuator Sizing and Selection in the HVAC Systems/Controls Reference Data* (Document Number 125-1853) for additional sizing information and 155-219P25 (TB-181) for additional torque requirements.

Table 1. Thrust Force and Torque Rating of LC Actuator.

| Operating Range Factory Setting psi (kPa) | Air Supply Pressure psi (kPa) | Available Thrust lb (N) | * Available Torque | |
|--|----------------------------------|----------------------------|--------------------|------------|
| | | | lb-ft (Nm) | lb-in (Nm) |
| 3-13 (21-90) | 25 (172) | 450 (2002) | 130 (177) | 1560 (176) |
| 3-13 (21-90) | 30 (210) | 530 (2359) | 150 (204) | 1800 (203) |

* With maximum hysteresis of 1-1/2 psi (10 kPa) and crank radius for 90° rotation.

Operation

The LC Actuator has three basic components: an air cylinder, a positioning relay, and a reverse acting (multi-purpose) relay as shown in Figure 5.

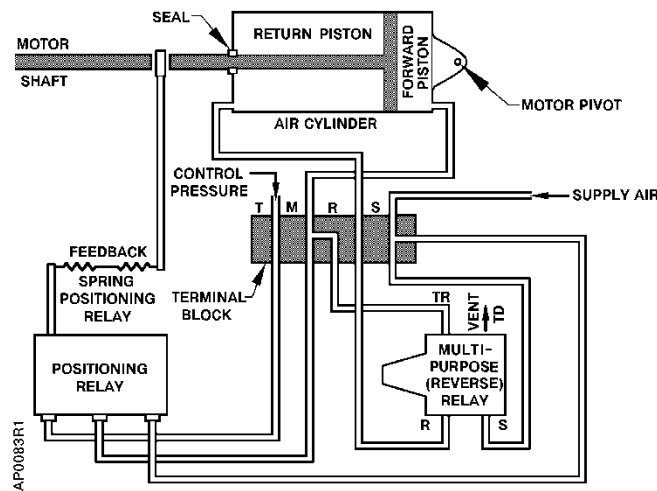

Figure 5. LC Actuator - Basic Operation.

With an increase in control pressure, the positioning relay increases pressure to the forward side of the piston. At the same time, the reverse acting relay decreases pressure on the return side to advance the piston stroke. The actuator will come to rest when the feedback spring balances the force of control pressure. Any load change increases or decreases the force on the actuator shaft. This is sensed immediately by the feedback spring. The positioning relay will maintain the actuator position regardless of load. As control pressure is decreased, the positioning relay will decrease the pressure on the forward side of the piston and reversing the relay will increase pressure to the return side of the actuator piston.

Operation of the reverse acting relay is as follows: "R" pressure equals spring adjustment pressure minus "TR" pressure. "R" is the return piston pressure and "TR" is the forward piston pressure. The adjustment spring can be adjusted for any pressure equal to or less than supply air pressure.

The positioning relay is factory set for a span of 10 psi (69 kPa) and adjusted to start movement at 3 psi (21 kPa). Other ranges are selected by positioning the spring guide on the feedback arm. There is one limitation to selecting a starting point and operating span; the sum of the starting pressure and the operating span pressure for full travel cannot be greater than the supply pressure to the actuator.

This is a piston type actuator which requires air pressure to position the actuator shaft. If supply and control pressure go to 0 at the same time, the actuator shaft position will be unknown because of the many variables. Figure 1 shows one method of returning the actuator shaft to the desired position.

Calibration

Some means of varying the control pressure must be available either by using the control instrument or a gradual switch. A supply air pressure to the actuator ("S" Port of the terminal block) of 20 psi (138 kPa) is used for factory calibration. Recalibrate if a different air supply is used.

Calibration, Continued

Span Adjustment

For spans of 3 through 10 psig (21 to 69 kPa), do the following:

1. Check that the feedback spring is attached to the spring guide in the hole across from the number 10 in the feedback arm. This is identified as the standard location in Figure 6.
2. With a screwdriver, loosen the span adjustment screw. Move the spring guide on the feedback arm to the desired span setting reference number.
3. Tighten the span adjustment screw.

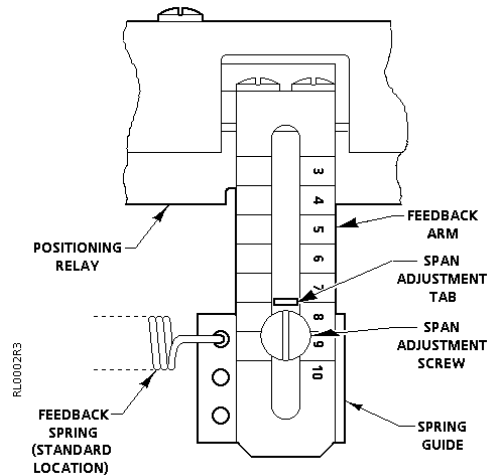

Figure 6. Span Adjustment.

For spans of 11 or 12 psig (76 or 83 kPa), do the following:

1. Make sure the spring guide is securely fastened at the 10 position on the spring arm. See Figure 6.
2. Move the feedback spring one hole away from the standard location for a span of 11 psig (76 kPa) and two holes away from the standard spring location for a 12 psig (83 kPa) span.

Checking the Span

1. Attach the tubing to the appropriate parts. Supply air to the "S" port, the actuator to the "M" port, and the control (input from the thermostat) pressure to the "T" port.
2. Insert a pressure gauge in the line from the "M" port.
3. Remove the relay cover.
4. Turn the start point adjustment nut clockwise (Figure 7) until you observe the movement of the actuator stem or shaft. Mark the start point with a pencil on the stem or shaft.
5. Record the pressure.
6. Increase the pressure until the actuator completes its full travel.
7. Record the pressure. The difference between the two pressures is the span.
8. If the span is not the desired span, adjust the span by moving the spring guide to a higher reference number to increase the span or lower number to decrease the span.
9. Repeat Steps 4 through 8 until you attain the desired span.

**Calibration,
 Continued**

Start Point Adjustment

The positioning relay can be adjusted to start actuator movement at pressures between 3 and 10 psig (21 and 69 kPa).

1. Observe the pressure at which the actuator shaft or stem begins to move.
2. If this is not the desired start point, turn the wheel clockwise to increase the start point pressure and counterclockwise to decrease the start point pressure.
3. Check the span again. Remove the pressure gauge and replace the relay cover.

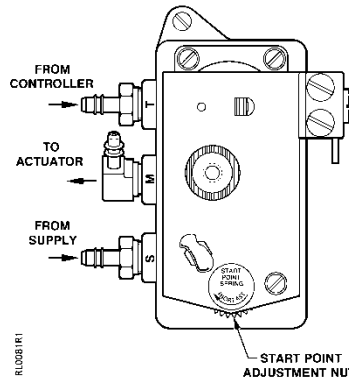

Figure 7. Start Point Adjustment.

**Installation - Fan
 Inlet Vanes**
 (Figure 8)

Use Table 2 to determine the location of the hole on the damper lever arm with respect to the pivot point for the various arcs of angular rotation.

Table 2. Lever Arm Length for Rotation.

| Lever Operating Arc "A" | Lever Radius "R" Inches (mm) |
|-------------------------|---------------------------------|
| 15° | 26-1/2 (673) |
| 30° | 13-1/2 (343) |
| 45° | 9 (229) |
| 60° | 7 (178) |
| 75° | 5-3/4 (146) |
| 90° | 5 (127) |

**To Determine Length
 ("L") of Pipe Required:**

Set the damper lever arm at the midpoint of its arc. Measure the perpendicular distance "H" from the center of the hole in the damper lever arm to the mounting surface. Use the following formula to determine "L":

$$L = H - 23\text{-}1/2 + TE$$

Where:

L, *H*, and *TE* are in inches (or millimeters), the number 23-1/2 inches (597 mm) allows for the length of the actuator (when the shaft is at half stroke), the clevis, both adapters, etc. *TE* is the thread engagement of the pipe in the two adapters.

Allow 1/2-inch (13 mm) of thread engagement for each end of the pipe. The connecting pipe must be provided at the job site.

Siemens Building Technologies recommends using 1/2-inch (13 mm) connecting pipe on lengths up to 7 feet (2.1 m). From 7 to 15 feet (2.1 to 4.6 m), use one-inch (25 mm) pipe with reducer fittings. The maximum recommended length of pipe is 15 feet (4.6 m).

When the damper lever arm is at the midpoint of its arc, the minimum distance between the center of the mounting hole on the arm and the mounting surface must be 24-1/4 inches (61.6 cm).

Installation

Fan Inlet Vanes, Continued

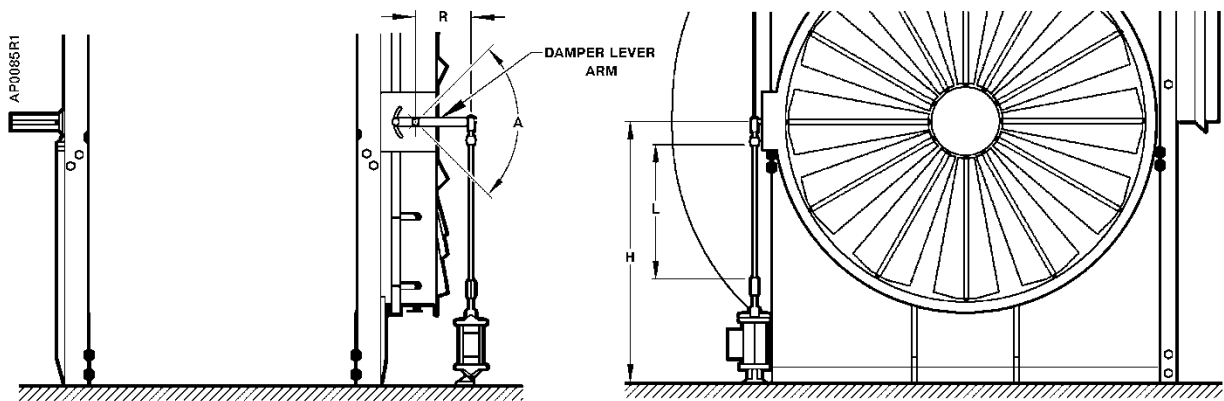

Figure 8. Fan Inlet Vanes Installation.

Maintenance

The air supply to the actuator must be clean and dry to assure proper operation. Siemens Building Technologies recommends using a refrigerated air dryer and coalescing filter in the air supply line leaving the air compressor. In addition, it is recommended that you use a 908-063 Inline Air Filter in the air line to the "S" port on the actuator terminal block.

To assure smooth operation of the actuator shaft, the following procedure is recommended. Approximately every six months, remove the two cylinder air fittings and spray a small amount of silicone lubricant, such as Zep Silicone Spray, into each opening. Replace the air fittings and move the piston through its full stroke, by alternately putting air pressure on one fitting, and then the other a few times to allow lubricant to cover all surfaces.

The wear on the actuator rod wiper and piston seals is dependent on the ambient temperature, the environment, and the frequency of stroking. A dirty environment and frequent stroking of the actuator will accelerate wear of the seals. Very high or very low ambient temperatures, or long periods of inactivity, will accelerate the aging of the seal material. It is recommended that the actuator seals be inspected after three years of operation. When the seals (Figure 10, Items 14, 15, and 16) must be replaced, use O-ring Kit 333-056.

Damper Actuator Components

Table 3. LC Part Identification.

| Item | Part No. | Description | Qty. | Material |
|------|----------|------------------------------|------|------------------------|
| 1 | 147-330 | 6-inch Feedback Spring | 1 | Zinc Plated Music Wire |
| 2 | 331-357 | Shaft Rod | 1 | Steel |
| 3 | 331-390 | Adapter | 1 | Steel |
| 4 | 331-356 | Shaft Collar | 1 | Steel |
| 5 | 034-386K | 1/4-20 x 5/16" Lg. Set Screw | 1 | Steel |
| 6 | 243-0009 | Multi-purpose Relay | 1 | — |
| 7 | 147-2000 | Positioning Relay | 1 | — |
| 8 | 331-766 | Terminal Block | 1 | Aluminum |
| 9 | 331-389 | Clamp | 2 | Stainless Steel |
| 10 | 331-350 | Clevis Pin (1/2" Diameter) | 1 | Steel |
| 11 | 045-108 | Cotter Pin | 1 | Steel |
| 12 | 331-349 | Clevis | 1 | Steel |
| 13 | 331-351 | Adj. Yoke End Adapter | 1 | Brass |
| 14 | ** | Rod Wiper | 1 | - |
| 15 | ** | Piston Seal | 2 | - |
| 16 | ** | Tube End Seal | 2 | - |

* Item Numbers are shown in Figures 9 and 10.

** Kit 333-056 (includes items 14, 15,16).

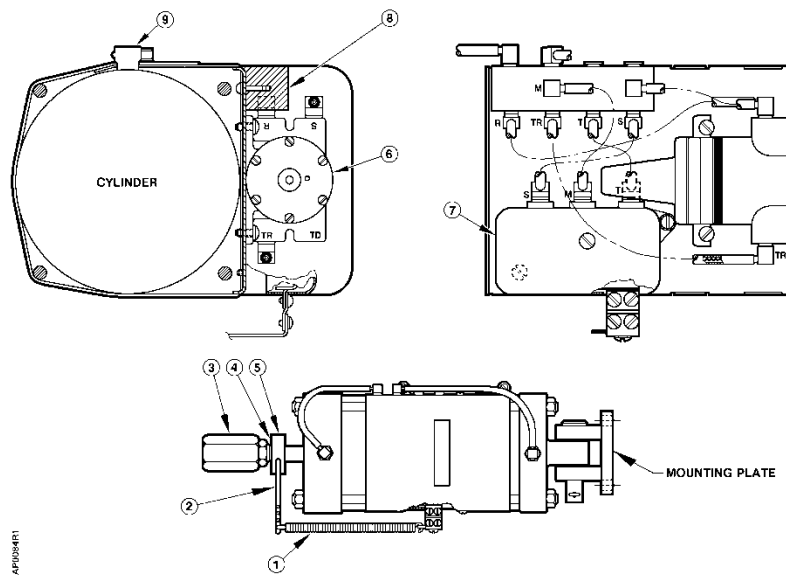

Figure 9. Piping and Call-outs.

Dimensions

Dimensions in Inches (Millimeters)

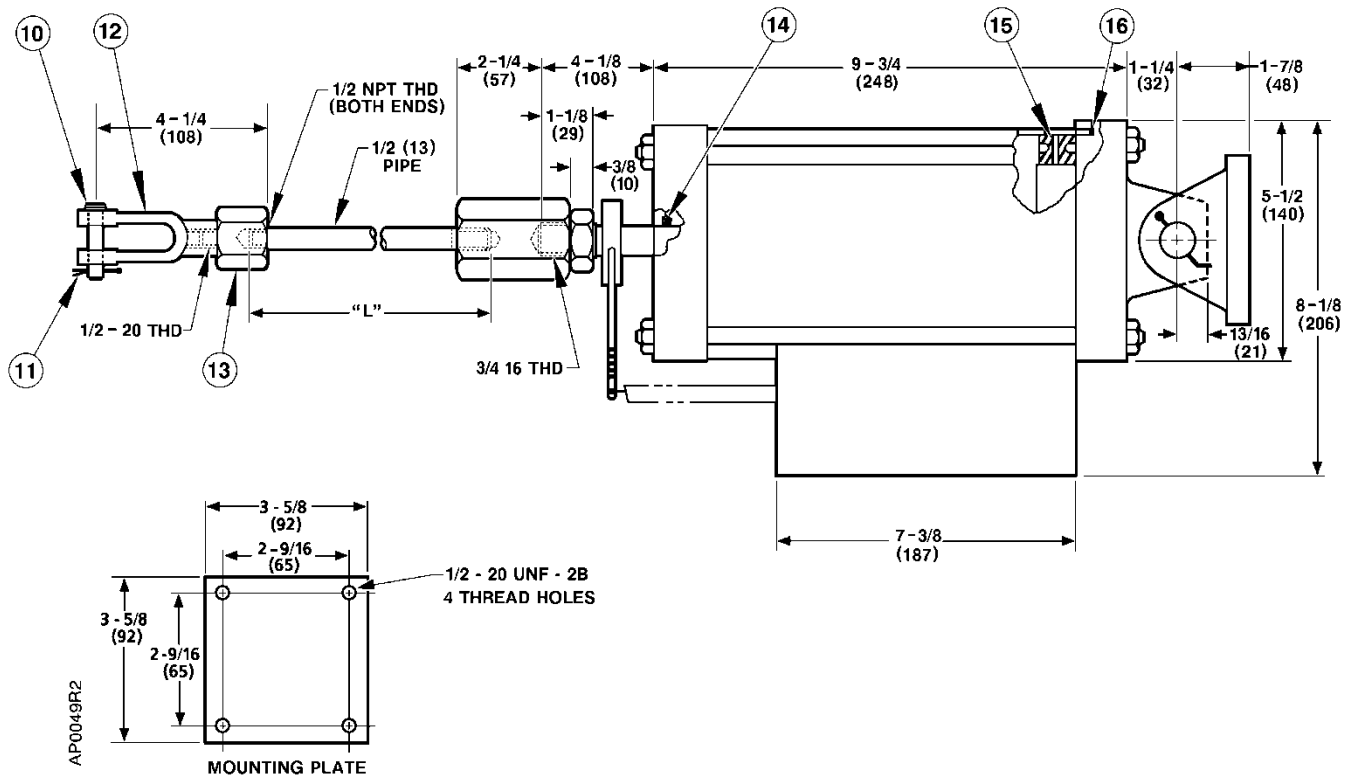

Figure 10. LC Actuator Dimensions.

Information in this publication is based on current specifications. The company reserves the right to make changes in specifications and models as design improvements are introduced. POWERS is a trademark of Siemens Industry, Inc. Other product or company names mentioned herein may be the trademarks of their respective owners. © 2017 Siemens Industry, Inc.