

# POWERS™ Controls

## Restrictors



**Type 2.** 1/4" (6.4 mm) O.D. Plastic Tube In-Line Restrictor.  
Typical 184-117



**Type 3.** 1/4" (6.4 mm) O.D. Plastic Tube Restrictor Tee.  
Typical 184-114

### Description

Powers restrictors are available in a variety of orifice sizes and connection types. External types 2 and 3 feature:

- Air filter.
- Barbed connection (Types 2 and 3).
- Color coding (Types 2 and 3).
- Airflow direction arrow to minimize installation errors.
- Airflow restrictor capacity molded (Types 2 and 3) or on body.

Restrictor installation kits and service repair kits are also available for Powers products that use plate or cartridge restrictors.

### Product Numbers

Table 1.

Type 1 In-Line Threaded (Package of 1)	Type 2 In-Line Barbed (Package of 5)	Type 3 Tee Barbed (Package of 5)	Barbed Restrictor Body Color	Normal Restrictor Flow Capacity scim (ml/sec)
—	184-115	184-112	Red	10 (2.7)
184-040	184-116	184-113	Yellow	20 (5.5)
—	184-117	184-114	Green	40 (11)
184-052	—	—	—	320 (87)

Table 2. Restrictor Flow Capacity At Various Air Pressure Drops.

Air Pressure Drop psi (kPa)	Percent of Maximum Flow Capacity	Nominal Restrictor Flow Capacity			
		10 scim (ml/sec.)	20 scim (ml/sec.)	40 scim (ml/sec.)	320 scim (ml/sec.)
22 (152)	100%	10 (2.7)	20 (5.5)	40 (11)	320 (87)
10 (69)	70%	7 (1.9)	14 (3.8)	28 (7.6)	224 (61)
5 (34)	50%	5 (1.4)	10 (2.7)	20 (5.5)	160 (44)
2.5 (17)	35%	3.5 (1.0)	7 (1.9)	14 (3.8)	112 (31)

**Specifications**

Material	Types 2 and 3	Plastic
Ambient Temperature	Minimum	40°F (4°C)
	Maximum	140°F (60°C)
Air Capacity		See Table 2
Air Connections	Types 2 and 3	Barb for 1/4-inch (6 mm) O.D. Polyethylene Tubing
Mounting		In-line

**Application**

External restrictors are used:

- for one-pipe transmitters, 40 scim (11 ml/sec). See Figures 1 and 2.
- when installed tubing lengths exceed maximum recommended value. See Figures 1 and 2.
- for one-pipe room thermostats, 20 scim (5.5 ml/sec). See Figure 3.
- with check valves to provide airflow time delays.
  - Slow to supply, fast to exhaust. See Figure 4.
  - Fast to supply, slow to exhaust. See Figure 5.
- for VAV vortex control. Use 80 scim (22 ml/sec) restrictor in actuator control pressure line to prevent cycling.
- when other air capacities, 10 scim (2.7 ml/sec), 80 scim (22 ml/sec) or 320 scim (87 ml/sec), are required to compensate for tubing size or response time.

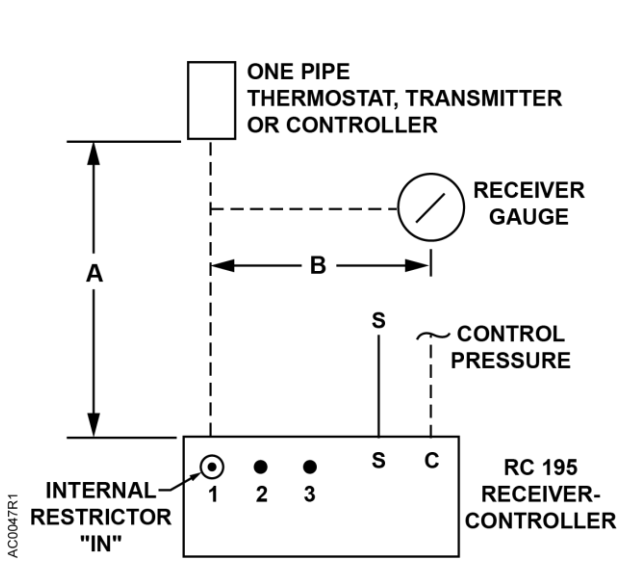

Distance "A" not to exceed 300 feet (91m). "A" + "B" not to exceed 1000 feet (305 m). If the transmitter is more than 300 feet (91 m) from RC-195, use an external restrictor, as shown.

**Figure 1. Transmitter/Receiver-Controller Application.**

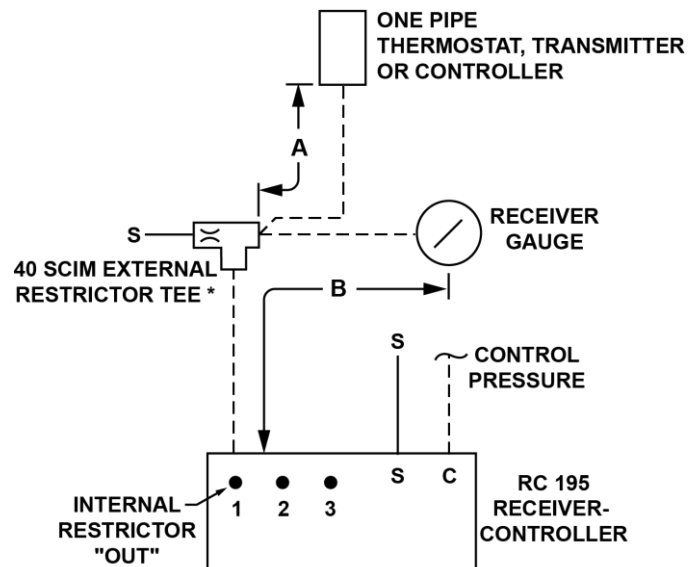

\* USE EXTERNAL RESTRICTOR WITH RC 195 WHEN "A" LENGTH EXCEEDS 300 FT. (91 m) OR WHEN "A+B" LENGTH EXCEEDS 1000 FT. (305 m).

**Figure 2. Transmitter/Receiver-Controller Application.**

**Application,  
 Continued**

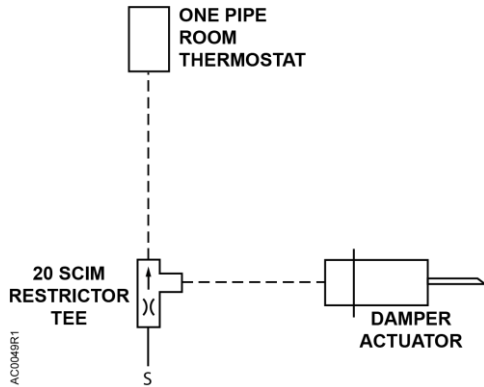

**Figure 3. One-pipe Thermostat Application.**

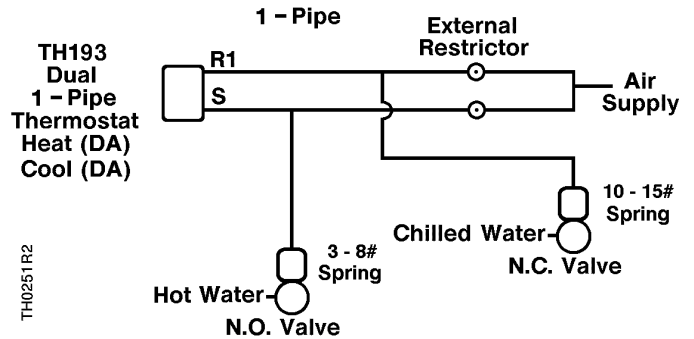

**Figure 4. Dual One-pipe Thermostat.**

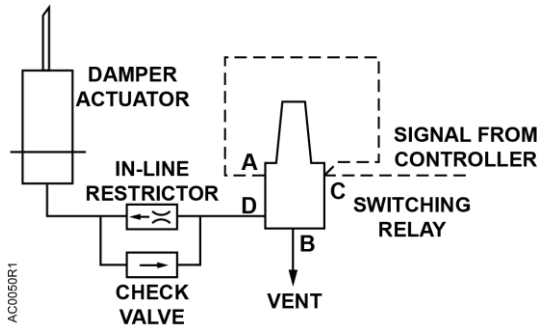

**Figure 5. Time Delay  
 Slow to Supply - Fast to Exhaust.**

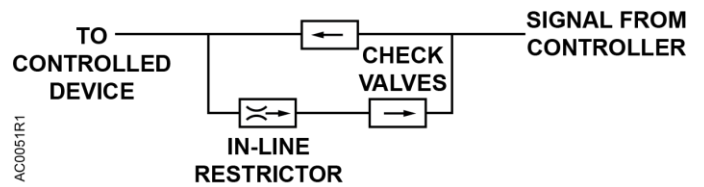

**Figure 6. Time Delay - Fast to Supply - Slow to Exhaust.**

**Installation**

Install external types 1, 2 and 3 restrictors so air flows in the direction indicated by the arrow. This ensures that only filtered air passes through restriction, reducing the possibility of clogging. Typical connections are shown in Figure 7.

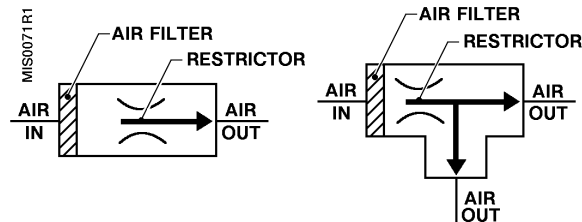

**Figure 7. Typical Connections.**

**Servicing**

If an external type 2, or 3 restrictor becomes clogged, it should be replaced. Do not attempt to replace the filter or clean the restrictor.

**External Restrictors**

TH182, TH192 Non Relay and **Free Energy Band™** TH193 HC (dual one-pipe) Thermostat External Restrictor Assembly. Kit 184-130.

The TH182 and TH192 non-relay (one-pipe) and **Free Energy Band** thermostats require external restrictors. The 184-130 restrictor kit is an assembly that permits easy installation of these thermostats. Kit 184-130 contains a supply air tee connected to two 20 scim (6 ml/sec) restrictor tees.

**Internal Restrictors**

TH180, TH182, TH188  
 Thermostat, HU 186  
 Hygrostat, and RL243 SS  
 Relay Restrictor  
 Replacement

The kit number, airflow, and usage information is shown in Table 3. The restrictor plates are shown in Figure 8. To install, remove the two screws holding the restrictor cover plate and replace the two gaskets and restrictor.

Kit 180-893 contains ten each of the lower gasket, upper gasket, and restrictor plate so ten thermostats or hygrostats can be serviced.

Kit 188-159 contains ten lower gaskets, ten upper gaskets, five 20 scim (6 ml/sec) restrictor plates and five 40 scim (11 ml/sec) restrictor plates.

**Table 3. Airflow and Usage.**

Restrictor Kit Product Number	Airflow with 20 psi (138 kPa) Differential Pressure scim (ml/sec)	Usage
180-893	10 to 15 (3 to 4)	TH180 and TH182 Thermostats HU186 Hygrostats
188-159	20 and 40 (6 and 11)	TH188 Thermostats RL243 SS Relay

TH192 Thermostat and  
 Hygrostat Restrictor  
 Replacement. Kit 192-321.

Kit 192-321 contains restrictor plates, upper gaskets, and lower gaskets. Each kit contains the parts to repair ten thermostats or hygrostats.

1. Remove thermostat or hygrostat from wall.
2. Remove the two screws holding the connector.
3. Remove the old gaskets, filters and restrictor plate.
4. Reassemble new kit parts, placing them in the same relative positions as the original parts (See Figure 9).

**NOTE:** The restrictor plate has a locating tab which fits in the space provided on the back of the unit.

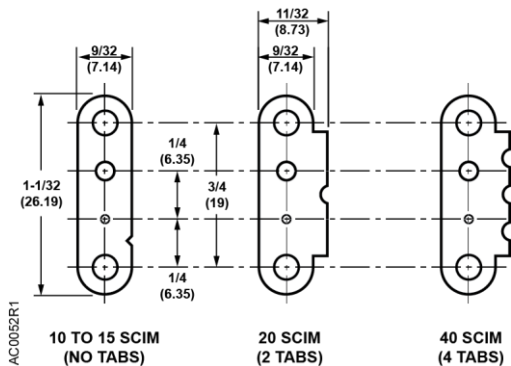

**Figure 8. TH180, TH182, TH188, HU186 & RL243SS Restrictor.**

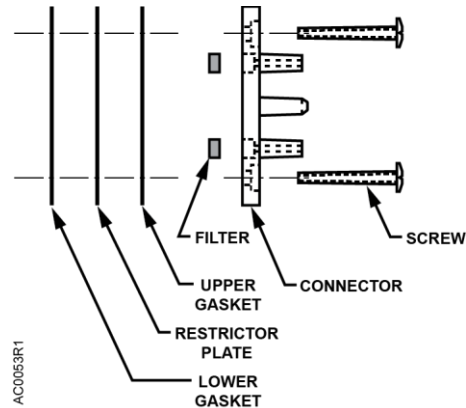

**Figure 9. Restrictor.**

RC 195  
Receiver-Controller  
Restrictor Replacement  
Kit 195-066.

The RC 195 Receiver-Controller restrictor replacement kit is 195-066. This kit contains three input restrictor assemblies, one supply restrictor assembly and seven gaskets. The restrictor assemblies are shown in Figure 10.

To replace Input Restrictor Assembly:

1. Remove two holding screws and lift off restrictor cover.
2. Remove and replace input restrictor assembly and two gaskets.
3. After replacing restrictor cover, tighten screws loosely so restrictor assembly can move.
4. Move restrictor assembly up and down several times to align gaskets.
5. Move lever into correct "In" or "Out" location.
6. Tighten both screws together. Draw assembly up snugly but do not over-tighten.

To replace Supply Restrictor Assembly:

1. Remove two holding screws and lift off restrictor cover.
2. Remove and replace supply restrictor assembly and gasket.
3. After replacing restrictor cover, tighten screws together. Draw assembly up snugly but do not over-tighten.

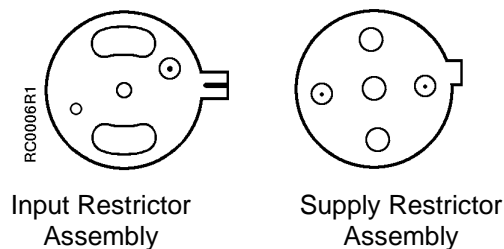

Figure 10. RC 195 Restrictor.

## Dimensions

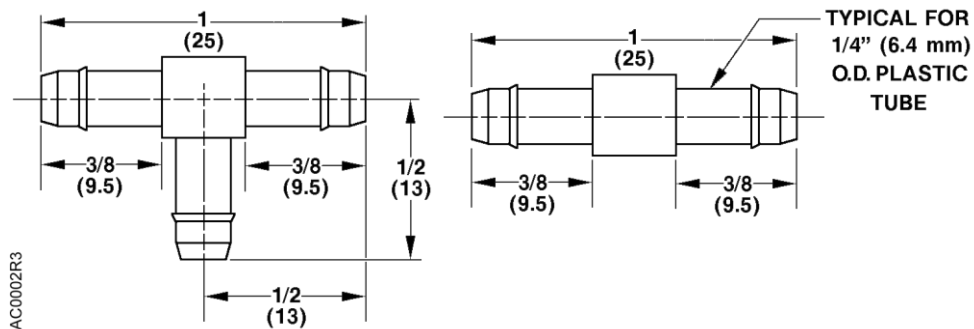

Figure 7. Dimensions in Inches (Millimeters).

Information in this publication is based on current specifications. The company reserves the right to make changes in specifications and models as design improvements are introduced. POWERS and **Free Energy Band** are registered trademarks of Siemens Industry, Inc. Product or company names mentioned herein may be the trademarks of their respective owners. © 2001-2022 Siemens Industry, Inc.