

Free Energy Band™ TH193 HC Heating/Cooling Room Thermostat

Product Description

The TH193 HC thermostats are proportional dual output, dual setpoint, two-pipe (dual one-pipe, low air capacity) or three-pipe (dual two-pipe, high air capacity) temperature controllers. Each TH193 HC chassis includes a wall plate for thermostat installation using a variety of rough-in installation kits.

Prerequisites

- Review all instructions before beginning installation.
- Verify job drawings are available to reference specific job site information as needed.
- Verify rough-in installation kits (wall-box or tubing runs) are pre-installed.



Expected Installation Time

30 Minutes

Required Tools

- Medium flat-blade screwdriver
- Needle nose pliers
- Small level
- Calibration and cover screw wrench or 1/16-inch Allen wrench (P/N 192-632)
- Needle Probe with 1-1/2 inch diameter, 0 to 30 psig (0 to 200 kPa) test gauge (P/N 192-633)

Warning/Caution Notations

WARNING		Personal injury or loss of life may occur if a procedure is not performed as specified.
CAUTION		Equipment damage or loss of data may occur if the user does not follow a procedure as specified.

Installation

Overview

The TH193 HC thermostat and wall plate mount vertically to a wall using a variety of rough-in installation kits (for example, wall box kits or tubing terminal kits). The ends of the air lines from the rough-in installation kits have terminal adapters that snap into the wall plate. Terminal adapters are also available separately as orderable accessories. See TB 237 (155-244P25).

NOTE: Certain retrofit applications allow air connections directly to the thermostat chassis.

The **S**, **R1**, and **R2** labels on both the thermostat chassis and the wall plate identify the air line connections. The thermostat plugs into the terminal adapters on the wall plate. See *Piping* for typical connections.

Two cover screws plus latch arms on the wall plate hold the thermostat in place. The cover fits over the thermostat and the two cover screws fasten it to the wall plate.

Procedure

The following procedure is for a typical thermostat installation and assumes the rough-in installation kit is in place. See Figure 1.

1. The rough-in installation kit provides a supply (blue) air line and a return air line joined by an air link. Remove the terminal adapters from the air link and snap them into the wall plate at their respective locations.
2. Using the mounting screws supplied with the thermostat chassis, install the wall plate on the wall as follows:
 - a. Guide the screws through the slotted keyholes on the wall plate and partially insert them into wall.
 - b. Orient the wall plate so that it is square and level.
 - c. Tighten the mounting screws to secure the wall plate in place.

- Moisten the thermostat supply and return ports to lubricate them. Carefully insert the thermostat ports into the terminal adapter O-rings on the wall plate.

- Mount the cover over the thermostat.

NOTE: For applications that use the 1/2-inch setpoint adjustment knob, align the keyhole in the cover over the shaft protruding from the thermostat when mounting the cover.

Use the hex key end of the calibration and cover screw wrench or a 1/16-inch Allen wrench to tighten the two screws that secure the cover in place.

- Place the optional 1/2-inch setpoint adjustment knob on the shaft protruding through the cover. Use the hex key end of the calibration and cover screw wrench or a 1/16-inch Allen wrench to tighten the set screw on the knob.

The installation is complete.

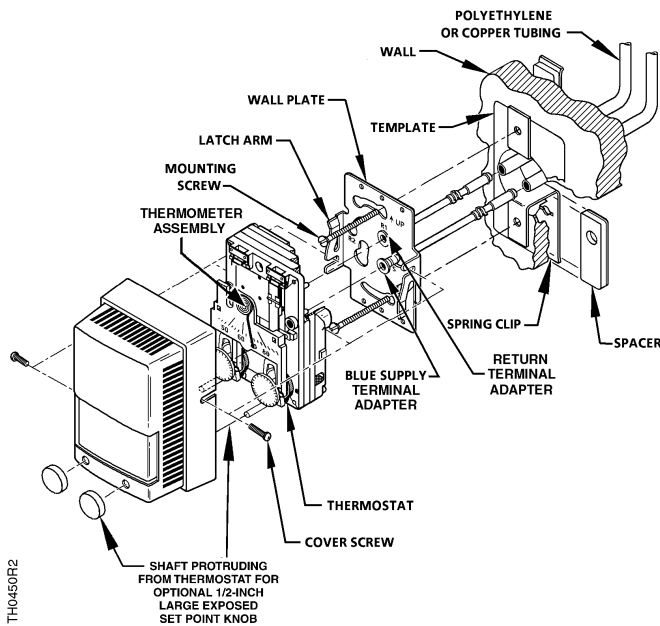

Figure 1. Thermostat Installation (using 192-481 Tubing Terminal Kit and 182-685 Dry Wall Mounting Kit.)

Remodeling Installation Reference

When converting from Model TH180 or TH182 to the TH19X, you need:

- TH193 HC Chassis.
- A new cover. The TH180 or TH182 cover does not fit the TH19X chassis or vice versa.

- Terminal adapters. These adapters are required to retain the plug-in feature only. Otherwise, 5/32-inch (4 mm) tubing can connect directly to the thermostat chassis. Use compression rings (P/N 141-388) to secure connections.

When converting from competitor models to the TH19X, you need:

- TH193 HC FEB Chassis.
- New cover.
- Adapter Kit (see TB 214, TH192 Adapter Kits Technical Bulletin, 155-231P25).

Piping

NOTE: All piping (Figures 2 and 3) must conform to local codes and regulations and must comply with the local authority having jurisdiction.

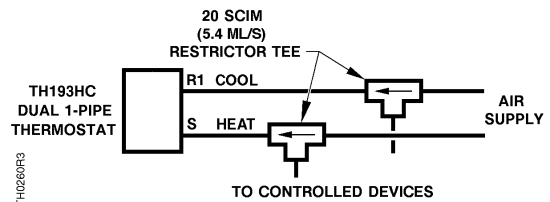

Figure 2. TH193 HC Thermostat Dual One-Pipe Connections.

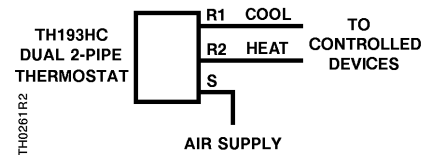

Figure 3. TH193 HC Thermostat Dual Two-Pipe Connections.

Thermometer Calibration

- Use a test thermometer to read the current room temperature.
- Place a screwdriver in the center of the thermometer assembly (Figure 4). Carefully rotate the thermometer assembly until the pointer tip indicates the correct room temperature.

NOTE: Avoid breathing on or touching the bimetal spiral since this affects the temperature reading.

Thermometer Calibration, Continued

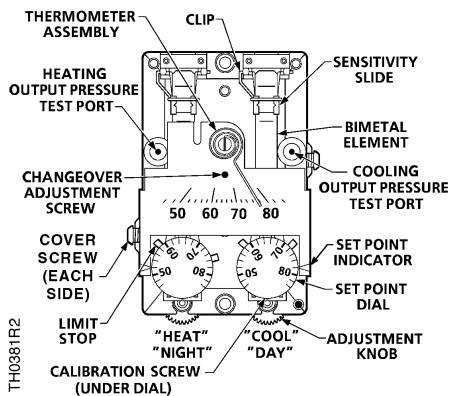

Figure 4. TH193 HC Thermostat Details.

Limit Stop Adjustment

Thermostat limit stops define the minimum and maximum thermostat setpoints. The limit stops engage in the setpoint cam gear teeth and cause interference between the setpoint cam gear and the adjustment knob gear.

To change the limit stop settings, use a needle nose pliers to pull limit stop (Figure 4) between the setpoint cam gear teeth. Do not pull the limit stop any more than necessary to clear the gear teeth. Rotate the limit stop to its new position. Changing the limit stop position one gear tooth changes the limit stop setting by 1-1/3°F (0.7°C).

Sensitivity Adjustment

The factory thermostat sensitivity setting is approximately 2.5 psi/°F (31 kPa/°C). To change the sensitivity, use a flat-blade screwdriver to carefully move the sensitivity slide (Figure 4) to the desired position as follows:



NOTE: If the thermostat sensitivity is adjusted, recalibrate the thermostat.

Thermostat Calibration

The thermostat is factory-calibrated to a control pressure of 7.5 psi (52 kPa) when the setpoint and the ambient temperature are both at 72°F (22°C). No adjustments are required if these settings are appropriate.

If the thermostat has been tampered with, the sensitivity changed, or it is out of adjustment, use the following procedures to recalibrate the instrument.

The output pressure test port (Figure 5) is accessible without removing the thermostat cover through the 8th opening from the top as follows:

- For one-pipe thermostats, the test port is on the *right* side.
- For two-pipe thermostats, the test port is on the *left* side.

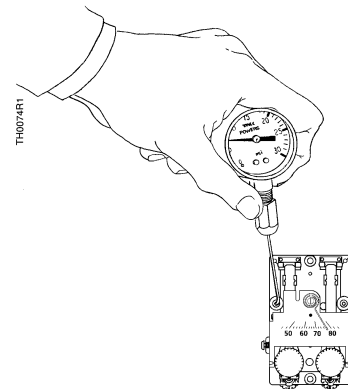

Figure 5. TH193 HC Output Pressure Heating Test Port.



CAUTION:

If you use the wrong test port, thermostat damage can occur and result in replacement of the device.

Cooling Calibration

1. Remove the cover using the calibration tool. Verify that the room temperature is between 70°F and 80°F (21°C and 27°C).
2. Verify that the supply pressure is 25 psi (172 kPa). Set the cooling dial to the room temperature by turning the exposed adjustment knob or using a hex key as shown. Allow the thermostat to stand for about five minutes to adjust to the new setting.
3. Moisten the needle and insert the test gauge and needle adapter in the cooling test port. Read the control pressure.
4. Check the control pressure. If it does not read 7 to 8 psi (48 to 55 kPa), turn the calibration screw (Figure 4) using the calibration tool or a 1/8-inch (3.2 mm) wrench until the pressure is 7 to 8 psi (48 to 55 kPa). The sensing element is now in calibration and the setpoint can be changed to the desired room temperature.

Heating Calibration

1. If not already done, remove the cover using the calibration tool. Verify that the room temperature is between 70°F and 80°F (21°C and 27°C).
2. Verify that the supply pressure is 25 psi (172 kPa). Set the heating dial to the room temperature by turning the exposed adjustment knob or using a hex key as shown. Allow the thermostat to stand for about five minutes to adjust to the new setting.
3. Moisten the needle and insert the test gauge and needle adapter in the heating test port (Figure 5). Read the control pressure.
4. Check the control pressure. If it does not read 7 to 8 psi (48 to 55 kPa), turn the calibration screw (Figure 4) using the calibration tool or a 1/8-inch (3.2 mm) wrench until the pressure is 7 to 8 psi (48 to 55 kPa). The sensing element is now in calibration and the setpoint can be changed to the desired room temperature.

Troubleshooting

Before troubleshooting the thermostat (see Table 1), make certain there is clean dry supply air at 18 psi (124 kPa) minimum. Use the test probe gauge and needle adapter to measure the control pressure at the output pressure test port (Figure 5). The output pressure test port is accessible without removing the thermostat cover through the 8th opening from the top as follows:

For one-pipe thermostats, the test port is on the *right* side.

For two-pipe thermostats, the test port is on the *left* side.



CAUTION:

If you use the wrong test port, thermostat damage can occur and result in replacement of the device.

Table 1. Troubleshooting Guide.

Problem	Check	Cause	Action
Control pressure stays at approximately zero	Air supply	Low supply pressure	As required
	Nozzle or flapper	Dirt on nozzle or flapper	Clean nozzle or replace thermostat
	Restrictor	Clogged restrictor	Replace restrictor
	Calibration	Out of calibration	Recalibrate
Control pressure stays at approximately supply pressure	Nozzle	Clogged nozzle	Clean nozzle or replace thermostat
	Calibration	Dirt on either supply or exhaust valve seat	Alternately close and open nozzle by gently pushing down the bimetal
Excessive air leakage from exhaust port on left side of thermostat	Supply and return line connection	Connections are interchanged or connection to port is incorrect	As required

References

Document	Number
Free Energy Band TH193-4, TH193HC Heating/Cooling Room Thermostat Technical Instructions	155-068P25
TB 214, TH192 Adapter Kits Technical Bulletin	155-231P25
TB 237, Accessories for Installation of TH192, Free Energy Band TH193, or TH194 Room Thermostats Technical Bulletin	155-244P25

Dimensions

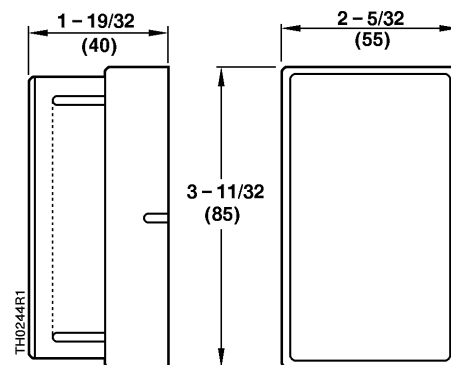

Figure 6. TH193 HC Dimensions in Inches (Millimeters).

Information in this publication is based on current specifications. The company reserves the right to make changes in specifications and models as design improvements are introduced. **Free Energy Band** is a trademark of Siemens Industry, Inc. Product or company names mentioned herein may be the trademarks of their respective owners. © 2009-2022 Siemens Industry, Inc.