

Powers® Controls No. 6 Damper Actuator

Product Description

The No. 6 Damper Pneumatic Actuator is a heavy duty, rolling diaphragm, spring return actuator designed to drive large dampers, centrifugal refrigeration inlet vanes, and other applications requiring a large, effective diaphragm area and long stroke.

Required Tools

- Flat-blade screwdriver
- Adjustable crescent wrench
- Pliers

Prerequisites

- Ensure all kits are ordered and available for installation. Kits are listed with each mounting application.
- Have the damper manufacturer drill mounting holes.
- Have the damper manufacturer weld mounting lug to damper frame for Frame Mounting—Type B installations.

Product Numbers

Description	Mounting Style	Product Numbers		
		Nominal Spring Range		
		3-8 psi (21-55 kPa)	3-13 psi (21-90 kPa)	8-13 psi (55-90 kPa)
Actuator, integral pivot	Pivot	331-2793	331-2794	331-3060 ¹
Actuator, integral pivot and forward travel stops	Pivot	—	—	331-2988
Actuator with clevis	Pivot ²	331-2857	331-2858	331-2856 ¹
Actuator with clevis and positioning relay	Pivot ²	—	—	332-2856
Actuator, integral pivot with pivot post ³	Extended Shaft	331-3012	331-3013	331-3011 ¹
Actuator, integral pivot with pivot post and positioning relay ³	Extended Shaft with Positioning Relay	—	—	332-3011

¹ UL Recognized Components for Fire/Smoke Applications.

² Also order frame mounting kit accessories.

³ Mounted on plate for extended shaft with clevis and crank for 3/8-inch (10-mm), 7/16-inch (11-mm), or 1/2-inch (13-mm) diameter shaft. Parts for frame mounting (blade drive) included with kit.

NOTE: When the actuator is ordered with universal mounting, the mounting plate, pivot post and hardware, clevis, damper crank, rocker arm, and all screws/nuts are included. Order other frame mounting accessories as required if not supplied by damper manufacturer.

Installation

Extended Shaft Mounting – Pivot Actuator

Expected installation time: 28 minutes

Actuators: 331-3012, 331-3013, 331-3011, or 332-3011. These assemblies are designed for 90° damper rotation.

NOTE: Clevis mounts in crank radius hole No. 1 for 90° damper rotation.

1. Slip 3/4-inch (19-mm) diameter hole in the mounting plate over the damper shaft (Figure 1).

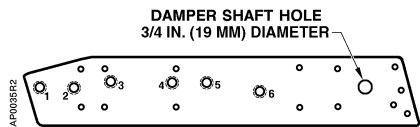

Figure 1. Actuator Mounting Plate.

2. Slip the crank over the 3/8-inch through 1/2-inch (10-millimeter through 13-millimeter) diameter damper shaft (Figure 2).

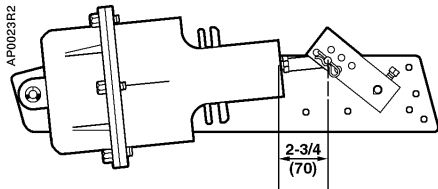

Figure 2. Extended Shaft Mounting.

3. Position the mounting plate and attach it to the duct with 4 screws.

Frame Mounting – Type A

Actuator and Clevis Assembly: 331-2857, 331-2858 or 331-2856.

Frame Mounting Kit: 751* for one-section damper, or 752* for two-section damper.

* Order from Arrow United Industries.

NOTE: Have manufacturer drill holes in damper frame and damper blade(s). Specific locations of holes are shown in the *AP 331-3 Powers™ Controls No. 6 Pneumatic Damper Actuator Technical Instructions*, (155-029P25).

One-Section Damper (Kit 751)

Expected installation time: Two hours

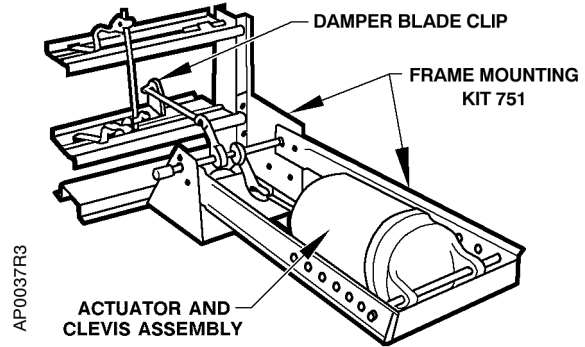

Figure 3. One-section Damper.

1. Attach damper mounting bracket to lower right-hand corner (or upper left-hand corner, if necessary) of damper section with six screws provided. For Arrow 1770 Dampers, add shim provided between brackets and bottom of frame.
2. Attach damper blade clip (included) to damper blade (Figure 4). Use the same clip location for both normally open and normally closed dampers. Put damper in its normal position, open or closed. Connect push rod to trunnion in blade clip and tighten setscrews. Connect other end of push rod to crank on drive shaft and tighten trunnion setscrew on push rod. Position crank so push rod is parallel to bracket, then tighten crank setscrews.

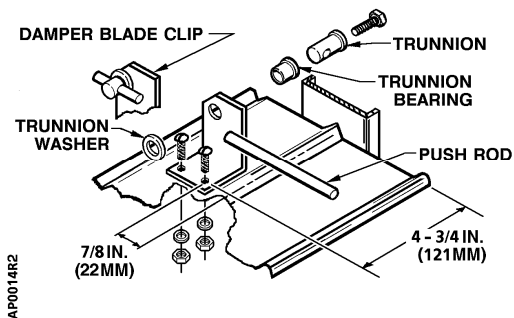

Figure 4. Damper Blade Clip.

3. Install actuator in actuator support bracket using pivot shaft and hitch pins. Pivot shaft should be in holes about 17-1/2 inches (445 mm) from drive shaft. The actuator support bracket can also mount in the vertical position for installations where space is limited.

4. Position crank drive by actuator as follows:
 - a. Normally open dampers: crank is above drive shaft.
 - b. Normally closed dampers: crank is below drive shaft.
5. Connect actuator clevis to crank. Place damper in its normal position, open or closed. Stroke actuator 1/4-inch (6-millimeter) with hand pump, and then tighten crank setscrews. This will ensure a tight damper closure.

The installation is now complete.

Two-Section Damper (Kit 752)

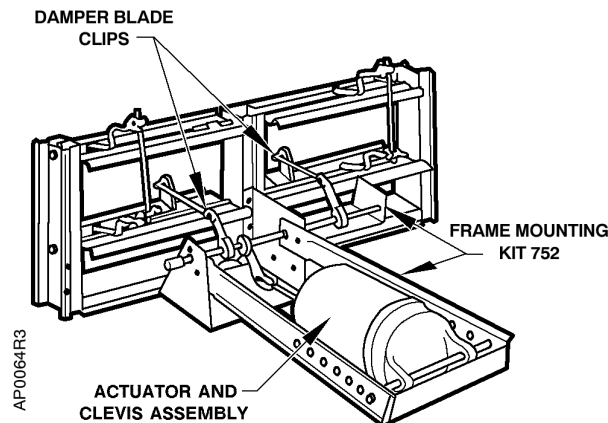

Figure 5. Two-section Damper.

Expected installation time: Two hours, 30 minutes

1. Follow the steps in *One-Section Damper*.
2. Attach Damper Blade Clip (included) to damper blade in second damper section. Repeat Step 2 in *One-Section Damper*. The push rod will connect to the extra crank on the drive shaft.

Frame Mounting – Type B

Expected installation time: Three hours

Actuator: 331-3012 (331-3013 or 331-3011)

Mounting lug: 331-569.

1. If damper frame is aluminum, light gauge sheet metal, or an unusual shape, bolt a 3/16-inch (5-millimeter) thick, flat piece of steel to the frame where the mounting lug is to attach. The mounting lug can then be welded to it.

2. Weld the mounting lug parallel and 5/16-inch (8-millimeter) from the inside edge of the damper frame and perpendicular to it (Figure 6). Weld the lug along both sides. The lug should be as close as possible to the corner of the damper frame to minimize deflection. The damper manufacturer should weld the lug.
3. If the damper frame is aluminum, light gauge sheet metal, or an unusual shape, bolt a 3/16-inch (5-millimeter) thick, flat piece of sheet metal to the frame. Then weld the mounting lug to it.
4. Attach rocker to blade in proper position for normally open or normally closed damper (Figure 6).

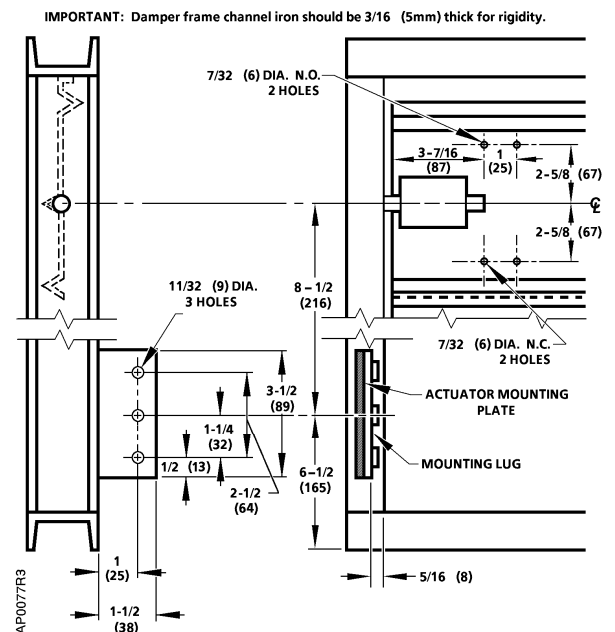

Figure 6. Frame Mounting-Type B Dimensions. Dimensions in Inches (Millimeters).

5. Attach mounting plate to mounting lug.
 - a. Normally closed damper: attach plate to lug (Figure 7). Place pivot post in Hole 3.
 - b. Normally open damper: attach plate to lug (Figure 8). Place pivot post in Hole 4.

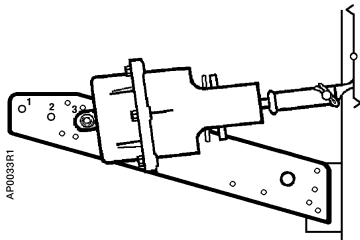

Figure 7. No. 6 Actuator Frame Mounting, Normally Closed Damper.

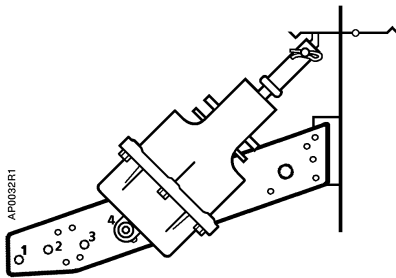

Figure 8. No. 6 Actuator Frame Mounting, Normally Open Damper.

6. Fasten clevis to rocker. Discard crank and other unused parts.
7. The actuator mounting plate has a tendency to pivot at the point where the lug is welded to the damper frame when the actuator strokes. It is recommended that some means be devised in the field to prevent this from happening. A threaded rod attached to the mounting plate and duct wall will normally work.

The installation is now complete.

Extended Shaft Remote Mounting (Figure 9)

Actuator: 331-2857, 331-2858, or 331-2856

Remote Mounting Kit: 331-618

1. Attach the mounting plate assembly to the mounting surface.
2. Attach the pivot post to the mounting plate assembly.
3. Slide the crank shaft into the bearing support.

Information in this publication is based on current specifications. The company reserves the right to make changes in specifications and models as design improvements are introduced. Powers is a registered trademark of Siemens Industry, Inc. Other product or company names mentioned herein may be the trademarks of their respective owners. © 2012 Siemens Industry, Inc.

4. Attach the two cranks to the crank shaft.
5. Position the actuator on the mounting plate and attach the clevis to one crank on the crank shaft.
6. To the other crank, attach a ball joint and a 3/8-inch (10-millimeter) diameter push rod (not provided) cut to the proper length.
7. Attach the remaining crank to the damper shaft and use the remaining ball joint to fasten it to the push rod.

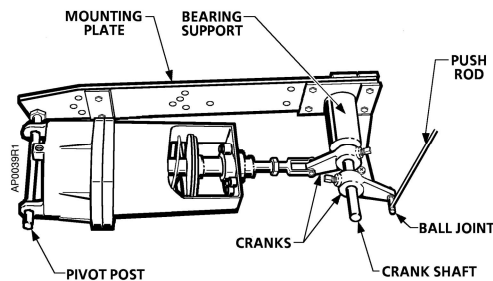

Figure 9. Extended Shaft Remote Mounting Assembly.

The installation is now complete.

References

AP 331-3, Powers™ Controls No. 6 Pneumatic Damper Actuator Technical Instructions, (155-029P25)

TB 181, Maximum Thrust Ratings of Pneumatic Damper Actuators Technical Bulletin, (155-219P25)