

Positioning Relay Mounting Kit No. 147-104

Product Description

This kit contains the parts needed to field mount the RL 147 Positioning Relay on the No. 3 Pneumatic Damper Actuator manufactured after January 1993.

Product Number

147-104

Required Tools

- Flat-blade screwdriver
- 5/8-inch (16 mm) hex wrench

Expected Installation Time

10 minutes

Prerequisites

- Clean, dry, oil-free air supply
- 147-2000 Positioning Relay
- If the actuator is already mounted to the damper, disconnect the crank arm by pulling the clevis pin before mounting the relay.

Installation

1. Attach the mounting bracket (1) to the lower housing of the actuator with screws (10).
2. Attach the relay to the mounting bracket with two captive screws furnished on the relay body. Loosen the cover screw to remove the cover for access to one of the screws.
3. Attach the relay feedback arm to the lever assembly of the relay using the two lock washers and two screws provided. The feedback arm must clear the mounting bracket and the actuator lower housing.
4. Thread the hex nut (8) onto the actuator shaft within 1/4-inch (6 mm) from the lower housing or the actuator. Put spring arm (7) against the nut and thread the clevis (9) onto the shaft against the spring arm as shown in *Figure 1*.
5. Align the opening in the spring arm with the spring guide. Tighten the hex nut against the spring arm to hold the spring arm in position.

NOTE: The position of the clevis may need to be adjusted to attach the crank arm.

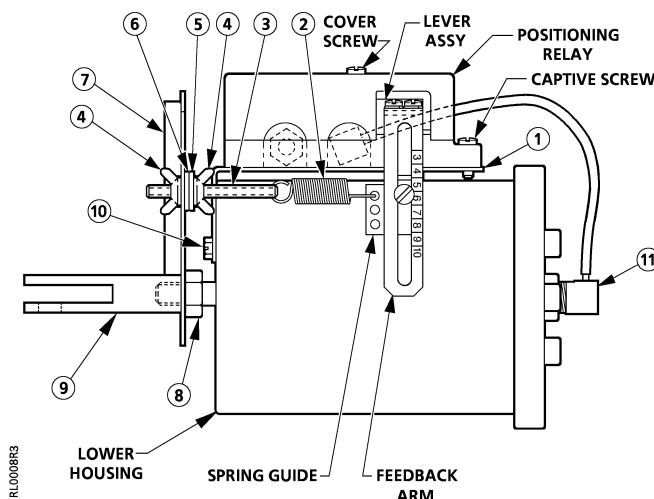

Figure 1. Positioning Relay 147-104 Mounting Kit on the No. 3 Damper Actuator.

Table 1. Mounting Kit 147-104.

Item	Description	Qty.
1	Mounting bracket	1
2	Feedback spring (for 2-3/8" stroke)	1
3	Adjusting screw 1-3/4" (44 mm) long	1
4	Wing nut	2
5	Lock washer	1
6	Flat washer	1
7	Spring arm	1
8	3/8-24 hex nut	1
9	Clevis	1
10	#10-16 1/2" (13 mm) Slotted hex screw	2
11	90° Elbow connector	1

Installation, Continued

6. Connect the feedback spring (2) between the spring guide and the adjusting screw (3). See *Figure 2*.

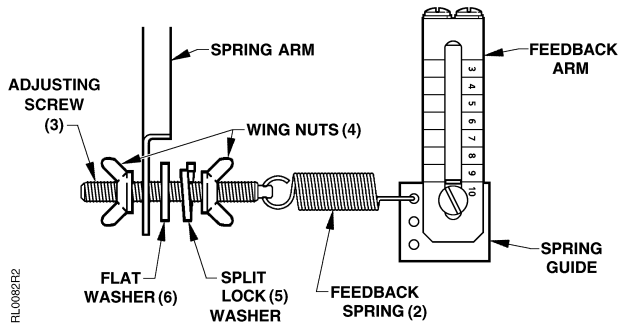

Figure 2. Attaching the Adjusting Screw to the Spring Arm.

7. Thread one wing nut (4), the lock washer (5) and the flat washer (6) onto the adjusting screw. See *Figure 2*.
8. Slide the adjusting screw through the spring arm. Thread the remaining wing nut onto the adjusting screw. Tighten the wing nuts so that there is no slack in the spring, but do not stretch the spring.

NOTE: Adjust the spring arm so that the adjusting screw and the feedback spring are parallel to the actuator shaft. The spring arm must not strike the crank arm when the shaft is extended.

9. Attach the connector (11) to the actuator. See *Figure 1*.

10. Make pneumatic piping connections to the actuator and relay. The "S" Port is the air supply port. The "M" Port goes to the connector (11) on the actuator. The "T" Port is the signal from the controller. See *Figure 3*.

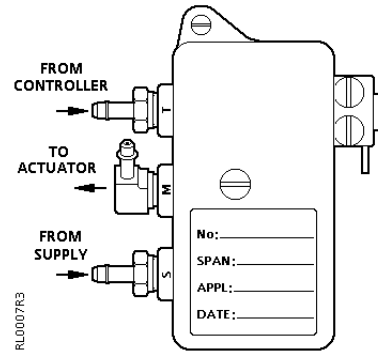

Figure 3. Mounting Relay Ports.

11. Place the calibration label on the cover as shown in *Figure 3*. Mark for reference. (Optional) Attach the relay cover if you are not calibrating immediately.
12. Calibrate the relay using the instructions included with the positioning relay.

The installation is now complete.

Reference

Technical Instructions 155-038
Powers™ Controls RL 147 Positioning Relay

Installation Instructions 129-125
RL 147 Positioning Relay Calibration

Information in this publication is based on current specifications. The company reserves the right to make changes in specifications and models as design improvements are introduced. Product or company names mentioned herein may be the trademarks of their respective owners. © 2009 Siemens Industry, Inc.