

SKD and SQX Weather Shield Assembly Kit

Product Description

The Weather Shield provides additional protection against the elements for SKD and SQX actuators in outdoor installations. The cover is easy to install; all necessary hardware is included in the assembly kit.

NOTES: 1. This unit is approved for outdoor installation only when a weatherproof conduit connector is used.

2. The SKD and SQX actuators are UL listed to meet NEMA Type 3R rating (a degree of protection against rain, sleet and damage from external ice formation) when installed with this Weather Shield in the orientations shown in Figure 1.

Product Number

599-10071

Contents

- Weather Shield cap
- Weather Shield side, male
- Weather Shield side, female
- Ten UV Resistant Cable Ties (For replacement ties, order 538-996 [package of 10])
- Actuator label

Installation Convention

CAUTION		Equipment damage or loss of data may occur if you do not follow a procedure as specified.
----------------	---	---

Required Tools

Diagonal cutters or utility knife

Prerequisite

Weatherproof conduit connectors are required if using this unit in an outdoor installation.

Expected Installation Time

15 minutes



CAUTION:

Over tightening cable ties can damage the assembly.

Mounting

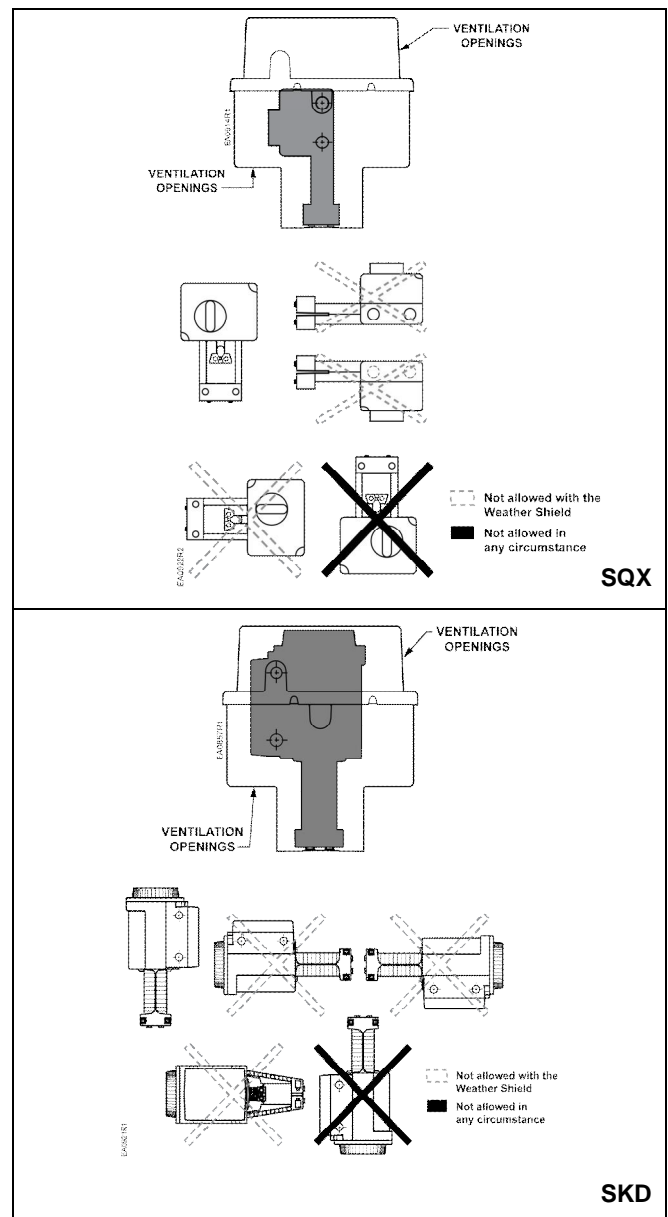

Figure 1. Mounting Orientation.

Installation

See Figure 2.

1. Apply label to actuator prior to installing the Weather Shield.
2. Install the appropriate weatherproof conduit connector(s) on the actuator.
3. Select the knockout that is intended for the SKD or SQX actuator. Using diagonal cutters or a utility knife, carefully remove the knockout piece to allow the conduit to protrude from the actuator.

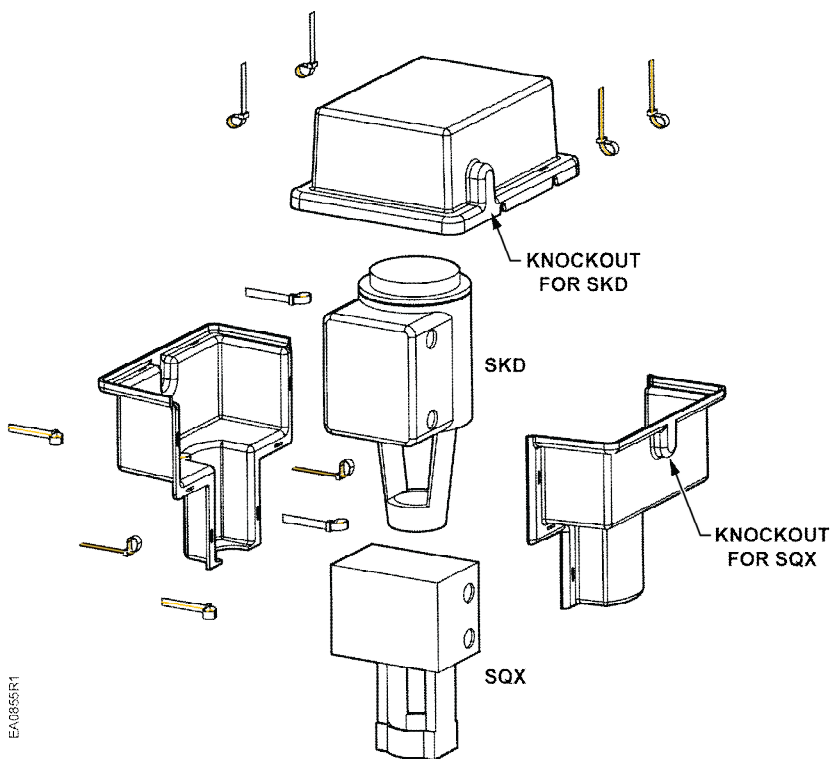

Figure 2. Installation.

4. Place the two Weather Shield sides around the actuator, overlapping the male side with the female side.

The valve will extend through the pre-cut opening in the bottom of the Weather Shield.

5. Align the holes in the side flanges and secure with six of the cable ties provided in the kit.
6. Align the holes in the cap flanges with holes in the top of the Weather Shield side flanges and secure with the four remaining cable ties.

The installation is now complete.

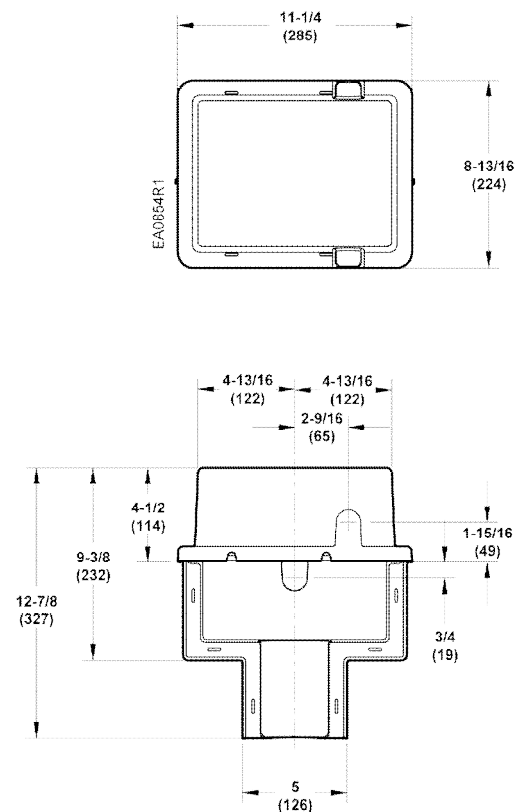

Figure 3. Dimensions in Inches (mm).

Information in this publication is based on current specifications. The company reserves the right to make changes in specifications and models as design improvements are introduced. Product or company names mentioned herein may be the trademarks of their respective owners.
 © 2018 Siemens Industry, Inc.