

## 599 Series Zone Valves STA/STP Thermic Actuators 2-Position or PWM Control



### Product Description

24 Vac/Vdc Zone Valve Thermic Actuator with a maximum stroke of 0.18-inch (4.5 mm).

### Contents

- One actuator with cable
- One bayonet nut

### Product Numbers

STA73U Normally Closed

STP73U Normally Open

### Warning/Caution Notations

<b>WARNING:</b>		Personal injury or loss of life may occur if you do not follow the procedures as specified.
<b>CAUTION:</b>		Equipment damage, or loss of data may occur if you do not follow the procedures as specified.

### Required Tools

No tools are required to mount the actuator to the valve. Best results are achieved by hand tightening.

### Expected Installation Time

15 minutes



#### CAUTION:

When selecting a heating or cooling on/off zone valve that must be closed for long periods of time or an entire season, use a Normally Closed actuator (such as the STA73U Actuator) for new or replacement applications.

If the valve needs to be open for extended periods of time or an entire season, use a Normally Open actuator (such as the STP73U Actuator) for new or replacement applications.

STP Actuators should not be used on hot water systems that remain operational all year long or where actuators are continually commanded closed during the summer.

### Installation

#### Installing the Actuator



#### WARNING:

Do not connect power until after the actuator is mounted to the valve.

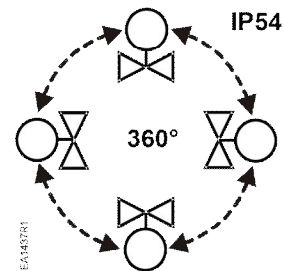

Figure 1. Acceptable Mounting Positions.

**NOTE:** Actuators may be installed in any position (360°).

1. Remove the black actuator support ring (AL50) from the top of the valve. Discard the ring; it is no longer needed.
2. Screw the bayonet nut (included with actuator) onto valve bonnet as tightly as possible, by hand. See Figure 2



#### CAUTION:

Do not use any tools such as pliers, pipe wrenches, or vice grips to tighten the nut. Doing so will damage the bayonet nut, and the actuator will not be able to properly mount to the valve.

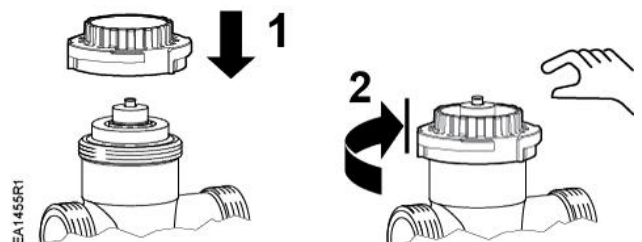

Figure 2.

- Place the actuator on the bayonet nut connected to the valve and twist the gray actuator bayonet ring (at the bottom of the actuator) clockwise until it clicks twice on the bayonet nut. See Figure 3.

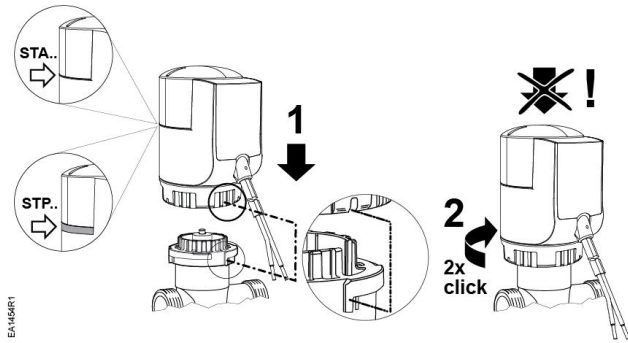

Figure 3.

The actuator is now properly attached to the valve.

### Removing the Actuator



**WARNING:**

Disconnect the actuator from the power supply before beginning.

- Wait at least six minutes until the actuator has cooled down.
- Twist the gray actuator bayonet ring counter-clockwise to the end position. It will click twice before it gets to the end position.
- Lift the actuator off the valve body and bayonet nut.

Dismounting the actuator according to these instructions will automatically set the actuator back to the original factory setting.

### Dimensions

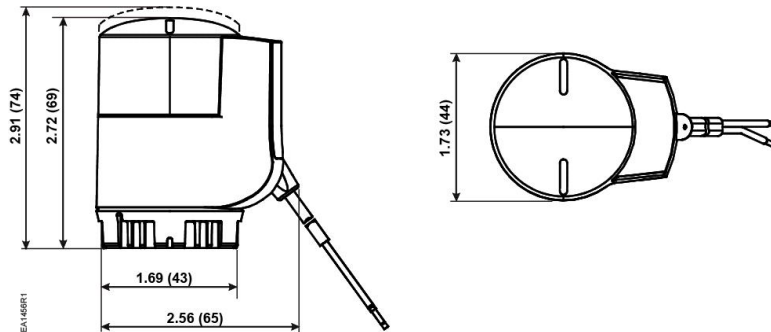
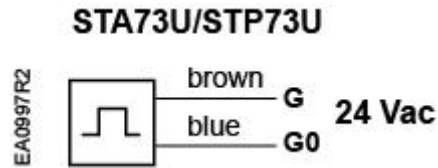

Figure 5. Dimensions in Inches (mm).

**NOTE:** Occasionally, the bayonet nut will come off the valve with the actuator when removing the actuator. If the bayonet nut starts to unscrew from the valve bonnet, twist the actuator bayonet ring clockwise as tightly as possible by hand to secure the bayonet nut to the valve. Then, repeat steps 1 through 3 in *Removing the Actuator*.

If the bayonet nut continues to unscrew from the valve body, completely unscrew the connected actuator and bayonet nut from the valve. To reuse the actuator, the actuator stem must be reset to the original factory setting position. To reset the stem, turn the actuator upside down, press down the actuator stem, and simultaneously twist the gray bayonet ring counter-clockwise until it latches into place, resetting the actuator to the original factory-setting position. The bayonet nut can now be removed from the actuator.

### Wiring



**NOTE:** G: positive  
 G0: neutral

Figure 4. Wiring Diagram.

Information in this publication is based on current specifications. The company reserves the right to make changes in specifications and models as design improvements are introduced. Product or company names mentioned herein may be the trademarks of their respective owners. © 2017 Siemens Industry, Inc.