



SAS61 Series Electronic Valve Actuators

Product Description

The SAS actuators require a 24 Vac or 24 Vdc, Class 2, supply and a 0 to 10 Vdc or 4 to 20 mA signal to control Powermite 599 Series terminal unit valves with 7/32-inch (5.5 mm) stroke. In the SAS61.33U, a mechanical spring returns the valve to its normal position when there is no power supply.

Warning/Caution Notations

WARNING:		Personal injury/loss of life may occur if you do not perform a procedure as specified.
CAUTION:		Equipment damage, or loss of data may occur if you do not follow the procedures as specified.

Product Numbers

SAS61.03U – Non-spring Return (Fail-in-place) actuator

SAS61.33U – Spring Return (Fail-safe) actuator

Required Tools

- #2 Phillips or flat-blade screwdriver
- Flat blade calibration screwdriver (3 mm) for wiring connections
- Wire cutter/stripper

Estimated Installation Time

- 12 minutes for wiring a factory-installed actuator.
- 30 minutes for field replacement of an actuator.

Prerequisites



WARNING:

Disconnect the controller power before replacing the actuator.



WARNING:

If mounting the actuator to a valve already in line, either close the shut-off valves in the piping (upstream first, then downstream) or switch off the pump to allow the differential pressure in the valve to drop.

Mounting

Figure 1 shows acceptable actuator mounting positions for water applications. The recommended mounting position of the actuator for low pressure steam applications is between 45° and horizontal.

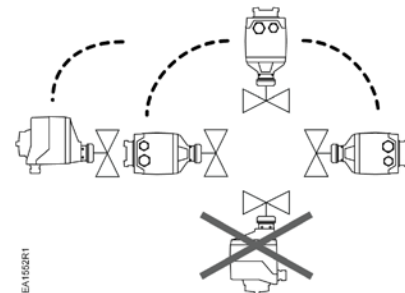

Figure 1. Acceptable Mounting Positions.

Installation

If you are mounting an actuator on a new valve, begin with the instructions, *Mounting an Actuator to a Valve*.

Remove Actuator from Valve

1. Remove actuator cover screws using either a No. 2 Phillips or a No. 2 flat-blade screwdriver and detach actuator cover.
2. Identify and disconnect wires.
3. Replace actuator cover. Use cover screws to secure actuator cover in place.
4. Loosen coupling piece.
5. Remove actuator from valve.

Mounting an Actuator to a Valve

1. If you are attaching the actuator to a new valve, remove the protective plastic cap from the valve stem.
2. On the SAS61.03U Actuator, turn the manual-positioning knob counterclockwise to its end point.
3. Place the actuator on the valve.
4. Hand-tighten the coupling piece.
5. Use either a Phillips head screwdriver or a flat-blade screwdriver to remove the actuator cover for access to the terminal block.
6. Attach wires. See *Wiring and Start-Up*.
7. Place the cover on the actuator.
8. Fasten the cover with the screws.

Wiring

All wiring must conform to NEC and local codes and regulations.

Use earth ground isolating, step-down Class 2 transformers. Do not use auto transformers.

Determine the supply transformer rating by adding the total VA of all actuators used. The maximum rating for Class 2 step-down transformer is 100 VA. It is recommended that no more than 10 actuators be powered by one transformer.

1. Remove actuator cover screws using either a No. 2 Phillips or a No. 2 flat-blade screwdriver and detach actuator cover.
2. Access terminal block and attach wires per Figure 2.
3. Replace actuator cover. Use cover screws to secure actuator cover in place.

G0	Neutral (-)
G	Hot (+)
Y	Positioning signal for 0 to 10 Vdc/4 to 20 mA
M	Measuring neutral
U	Position feedback 0 to 10 Vdc
Z	Positioning signal forced control AC/DC ≤ 24V, 0 to 1000 Ω

Figure 2. Terminal Connections.



WARNING:

Terminal connection G is 24 Vac HOT, not ground.



CAUTIONS:

- G0 and G must be properly wired for correct function and full life of the actuator.
- If the actuator makes a buzzing noise upon reaching setpoint, G and G0 are improperly wired and should be reversed.

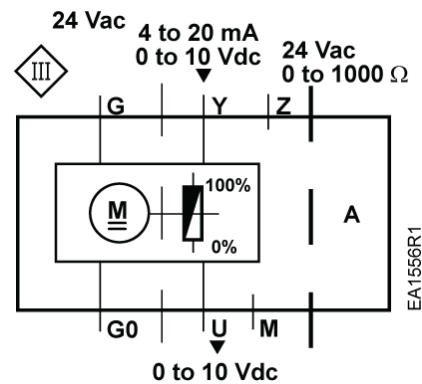

Figure 3. Wiring Diagram.

The diagram shows all possible connections. The application determines which connections are used.

Start-Up

The valve body (normally open or normally closed) determines the action of the complete valve/actuator assembly.

Troubleshooting

- Check wiring for proper connections and secure attachments.
- Check for adequate power supply.

References

Powermite 599 MT Series SAS Electronic Valve Actuators, 24 Vac or 24 Vdc, Proportional Control Technical Instructions (155-682).

Dimensions

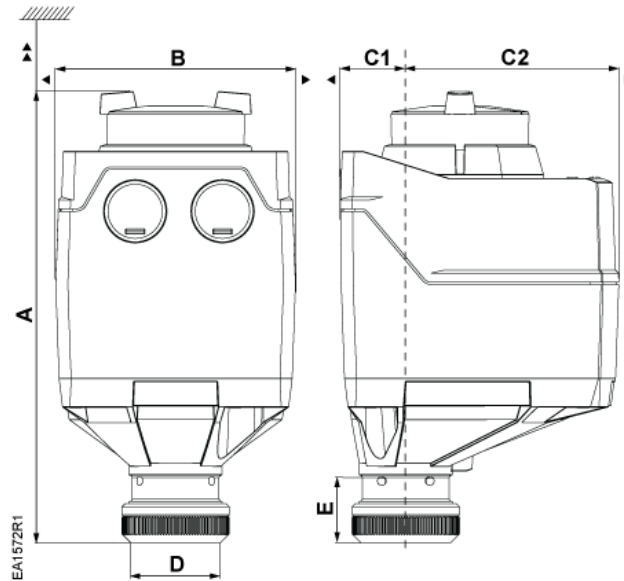

	A	B	C1	C2	D	E	▶	▶▶
Inches	5.9	3.1	0.9	2.8	1.2	0.9	4	8
mm	151	80	21.9	71.1	29.9	21.8	100	200

Figure 4. SAS61.03U Actuator Dimensions.

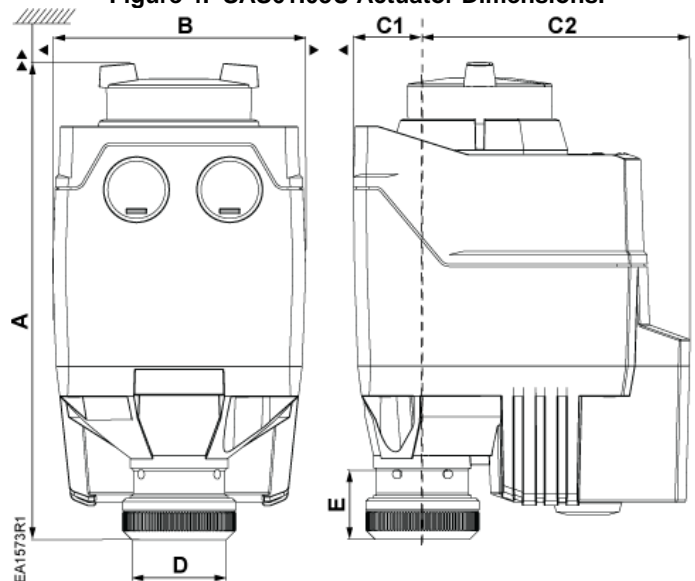

	A	B	C1	C2	D	E	▶	▶▶
Inches	5.9	3.1	0.9	3.3	1.2	0.9	4	8
mm	151	80	21.9	84.6	29.9	21.8	100	200

Figure 5. SAS61.33U Actuator Dimensions.

Information in this publication is based on current specifications. The company reserves the right to make changes in specifications and models as design improvements are introduced. Product or company names mentioned herein may be the trademarks of their respective owners. © 2016 Siemens Industry, Inc.