

Electropneumatic Transducers

EP2 Series

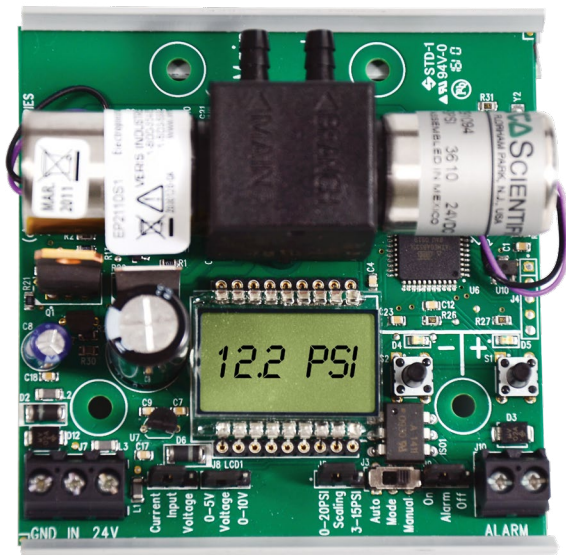

EP2



EP Series transducers are sold as an open device. Observe handling precautions for static sensitive devices to avoid damage to the circuitry which would not be covered under the factory warranty.

SPECIFICATIONS

5 Year
Warranty

Input Power	Class 2; 24VAC/DC nominal, 30VAC max.; 150mA max.
Control Input	Class 2; 4-20mA/0-5V/0-10VDC; jumper-selectable
Input Impedance	4-20mA, 250Ω; 0-5V/0-10VDC, 10 kΩ
Manual Override	Jumper-selectable mode, digital pushbutton adjust
Alarm Contact	100mA@30VAC/DC (Pressure loss, manual mode, jumper selectable)
Accuracy	1% FS; combined linearity, hysteresis, repeatability
Compensated Temp Range	-4° to 65°C (25° to 140°F)
Temperature Coefficient	±0.05%/°C
Operating Environment	10-90% RH noncondensing
Air Capacity	523 in ³ /min @ 45 psi (8570 cm ³ /min @ 310.3 kPa); 333 in ³ /min @ 20 psi (5456 cm ³ /min @ 137.9 kPa)
Supply Pressure	45 psig max.
Control Range	0-20 psig or 3-15 psig, jumper-selectable
Pressure Differential	0.1 psig (supply to branch)
Pressure Indication	Electronic, 3-1/2 digit LCD
Minimum Tubing Length	15 feet*
Port Connection	1/8" I.D. poly tubing
Media Connection	Clean, dry air, or inert gas. Do not use with oxygen service

*For shorter tubing runs use AA45 Pneumatic Capacitor

EMC Conformance - CE option: Low voltage directive 2006/95/EC; EMC directive 2004/108/EC.

EMC Special Note: Connect this product to a DC distribution network or an AC/DC power adaptor with proper surge protection (EN 61000-6-1:2007 specification requirements).

Micro-Controlled With High-Performance, Low-Power Coil Poppet Valve Technology

FEATURES

- Field-selectable 4-20mA/0-5V/0-10VDC input for application flexibility
- Poppet valve technology for quiet operation
- Manual override with set and hold feature...great for commissioning those leaky systems
- Multi-point calibration; 3-15 psi (5 point calibration) and 0-20 psi (6 point calibration)
- Pressure loss alarm provides a contact closure if the EP2 is unable to achieve the desired output within a fixed length of time
- Failsafe vent solenoids bleed branch pressure on power failure for added safety
- Optional transparent plastic dust cover (AA43) protects units from dust and tampering (required for CE)

DESCRIPTION

The **EP2 Series** electropneumatic pressure transducer uses micro-controlled poppet valve technology for highly accurate pressure sensing in multiple applications. The poppet valves consume no air, eliminating unnecessary air losses in the system and allowing for stable and reliable operation. The EP2 is comes installed on standard SnapTrack, and an optional dust cover is available to protect from the environment. An LCD display and LED indicators make it easy to read system status at a glance.

APPLICATIONS

- Hospitals
- Schools
- Pneumatic dampers/actuators

WIRING DIAGRAM

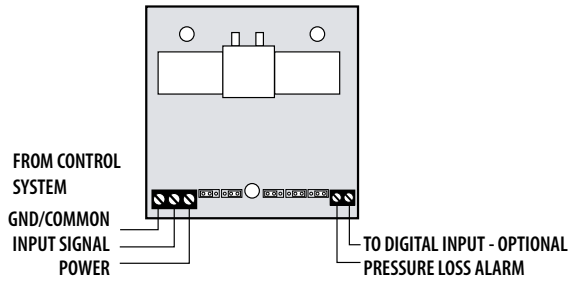

DIMENSIONAL DRAWINGS

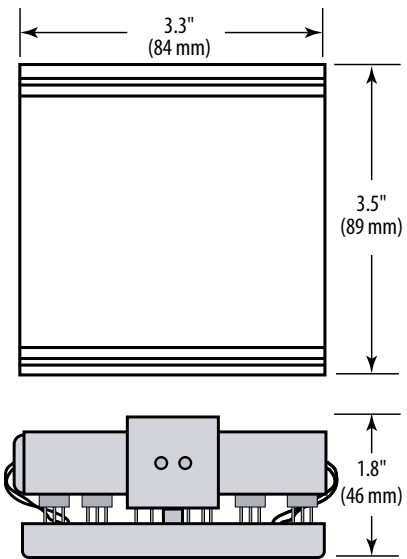

CONFIGURATION

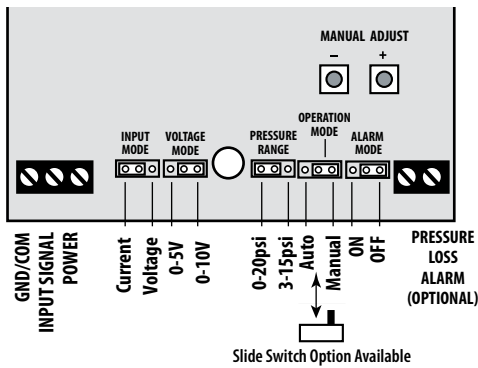

Dust Cover

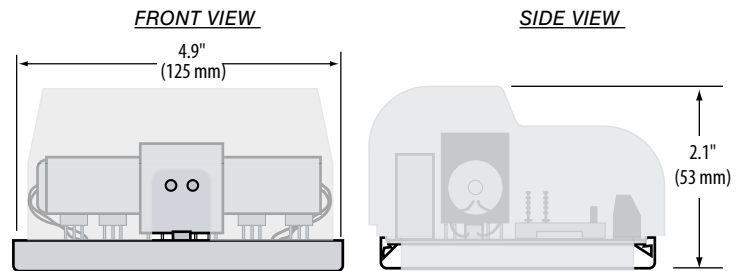

If the dust cover is ordered, the EP2 is mounted to a longer Snaptrack.

ORDERING INFORMATION



Output	Feedback	Failsafe	US or EU	Option
EP2 <input type="checkbox"/> 1	<input type="checkbox"/> 0	<input type="checkbox"/> 0	<input type="checkbox"/> S	<input type="checkbox"/> Blank
= Selectable 3-15/0-20 psi	0 = None 1 = Pressure Loss Alarm 2 = Manual Mode Alarm	0 = None 1 = Vent on Power Fail	S = Standard C = CE, includes cover plate	Blank = none 1 = Slide Switch/ Auto/Manual 2 = EP Cover Plate 3 = Slide Switch/ Auto Manual plus EP cover plate

Example:

EP 2 1 0 0 S 1 Option = Slide Switch Auto Manual Mode

ACCESSORIES

- Steel bracket (AA23)
- Dust cover (AA43)
- Pneumatic capacitor (AA45)

